

Grandt Line PRODUCTS, INC.

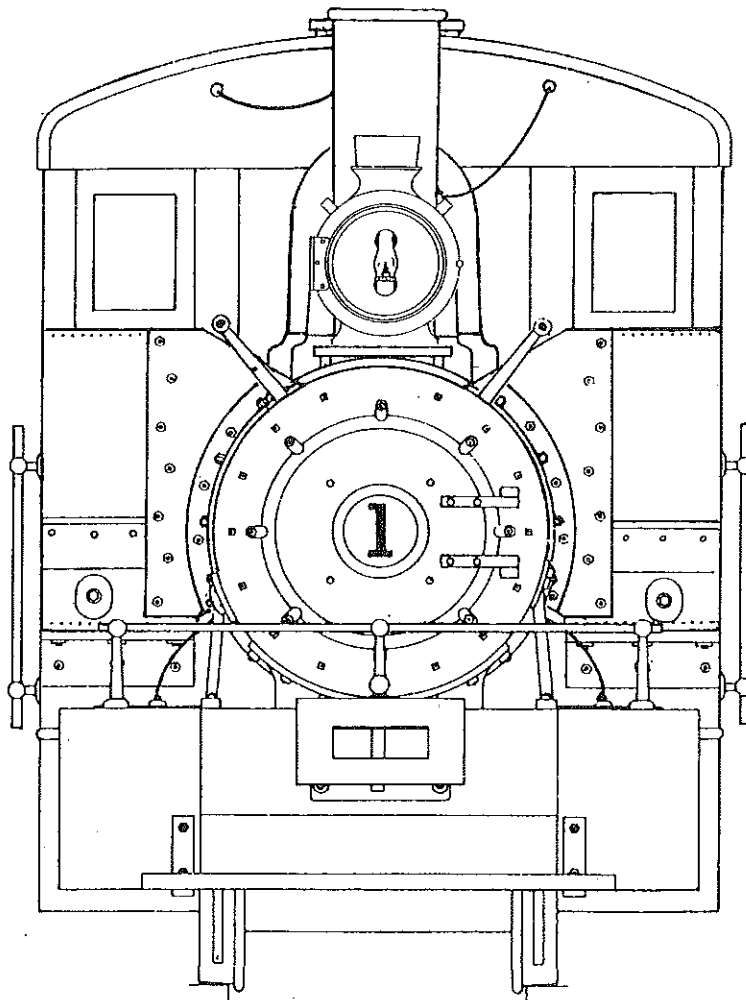

OFFERING THE O, S, HO AND N SCALE
MODELER AN ARRAY OF QUALITY PARTS
FOR LOCOS, CARS AND STRUCTURES

1040 B Shary Court, Concord, CA 94518
(510) 671-0143 FAX 671-0806

General Information on Usage of Grandt Line Parts	1
Painting Tips	2
1/4" Scale Kits	3
HK Porter Loco Kits	3
Plymouth Industrial Locomotives	5
C&S Steel Underframe Stock Car	5
C&S Caboose #1006	6-1
RGS Workgoose	6-3
D&RGW Drop Bottom Gondolas	6-4
C&S Steel Underframe Gondola	7-0
Fairbanks-Morse #37 Dump Car	7-1
UTLX Frameless Narrow Gauge Tank Car (Gramps)	7-2
All Scale Construction Materials	8
Plastic Rodding * Plastic Grating * Plastic Screws	
0 Scale (1:48) Parts	9
Architectural Parts	
Doors and Windows	9
Structural Details	9
hinges * brackets * gable and eave trim * railing *	
porch posts * lattice * brick cornice * shingles *	
shutters * chimneys * stacks * stoves	
Detailing Kit for Chama Coal Chute	18-2
Car Components	19
Box Cars	19
Caboose	20
Flats and Gons	21
Passenger Cars	23
Refrigerator Cars	26
Stock Cars	29
Miscellaneous Freight Car Hardware	30
lift ring/eyebolt * hinges * turnbuckles * queenposts	
post and brace tie rod plate	30
Nuts, bolts and washers * rivets	31
Bolster * brake wheels * brake fittings * brake cylinder	
brake sets	32
Couplers * lift bars * coupler pocket * stakes *	
stake pockets	34
Camel Side and end door set	34
Ladders * stirrup steps	35
Bettendorf Underframe Kit	36
Other Cars	36
1/4" Scale Figures	36
Loco Components	38
Mining and Construction	44
Track Components	46

O SCALE PARTS (CONT)

Trackside Details	47
Transmission Components	48
Trucks and Wheels	52

S SCALE (1:64) PARTS

Architectural Parts	56
Trucks and Wheels	62
Coach seats* Stake pockets * loco bell * ladder * hardware	62
Refer parts * stock car parts	58
Box car doors, hardware set * refer end detail	59
High-side gon hardware set * Porter loco conversion kit	60

GENERAL INFORMATION ON THE USAGE OF *Grandt Line* PARTS

Most of our parts are injection molded in medium impact black poly-styrene. Where bearing surfaces or parts are subject to breakage from handling, a few parts are molded in Delrin^R, in appropriate colors.

Parts shown are molded in Styrene, unless otherwise noted. All parts are drawn actual size. In some cases where enlargement is used to show detail, a black silhouette shows actual size.

Styrene parts may be cemented to other styrene parts using Testors Liquid or other liquid cements. Apply the liquid sparingly, using a 5-0 brush. Glue will not adhere to Delrin^R parts. It is necessary to *surround* these parts with cement. Styrene and Delrin^R parts may be applied to wood using any of the instant-set adhesives, such as S-Dine, Eastman 910, Loctite 404 or Crazy Glue.

Before assembling plastic models, a good modeler removes parting lines and sprue marks. This may be done with a razor knife or a small file.

Styrene and Delrin^R parts may be spray painted using any of the commercially available model railroad paint. Care should be taken not to apply the paint too heavily. Heavy coats of paint will cover the fine details on the part and can cause dissolving or "orange-peel" effects. If brush painting is necessary, apply a coat of Floquil Barrier and then apply paint sparingly.

Prototypes for *Grandt Line* Components are thoroughly researched. Our parts are as accurate as our information and the manufacturing process permit.

Narrow gauge plans and/or photos are available from the following sources:

Edmund G. Collins, Jr. Trexler Ave, Kutztown, Pa 19530

Coronado Scale Models 1544 E. Cypress St, Phoenix, Arizona 85006

Herman Darr PO Box 81, Hawthorne, Nevada 89415

John W. Maxwell 3220 Balsam Street, Wheat Ridge, Colo 80033

We feel that the most accurate plans and information are available from these sources. Accurate drawings have also been published by *Model Railroader* and *Railroad Model Craftsman*.

PAINTING TIPS

Proper painting techniques and equipment are not only important to the overall appearance of a model, but also help to bring out and enhance the fine detail that styrene injection molding makes possible.

Strikingly realistic results are possible using an air brush to apply several very light, successive oversprays of different colors over a base or primer coat. Previous colors should always be allowed to "bleed", or show through. Where styrene is used to represent wood, it should be distressed prior to the beginning of assembly. Very light distressing with the tip of a jewelers file may also be done after each overspray in order to help bring out the "grain" and give contrast between individual "boards".

Using Floquil colors, the following sequence of coats has been found to give excellent results for red freight cars. Thin the paint 50/50.

Begin with a coat of gray primer. Follow this with successive coats of Roof Brown, Depot Buff, Grimy Black, and a 50/50 mixture of Box Car and Tuscan Red. Add a final coat of Rock Island Maroon.

When the final color is a lighter version of the basic color, as for example, Rock Island Maroon is to the deeper red of the previous overspray), the natural air pattern from the air brush will allow fine details to be subtly highlighted, and, therefore, to be more visible.

After applying decals, a very light overspray of colors (such as Dust, Foundation or Grimy Black) can be used to tone down the decals and to kill any shine from the decal film. As with any new technique, some experimentation on scrap materials is recommended before trying on newly assembled models.

--Keith Burton Brown
Master Painter

H K Porter Company Four-Wheel-Connected Saddle-Tank Locomotive, Class B-S

For Contractors' Use, Shifting, and Special Services. Wide and Narrow Gauge.

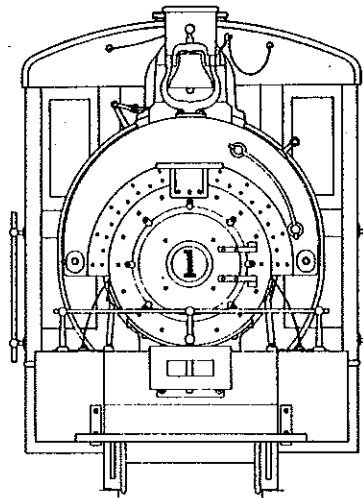
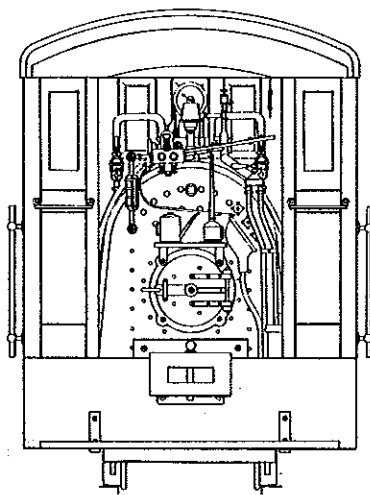
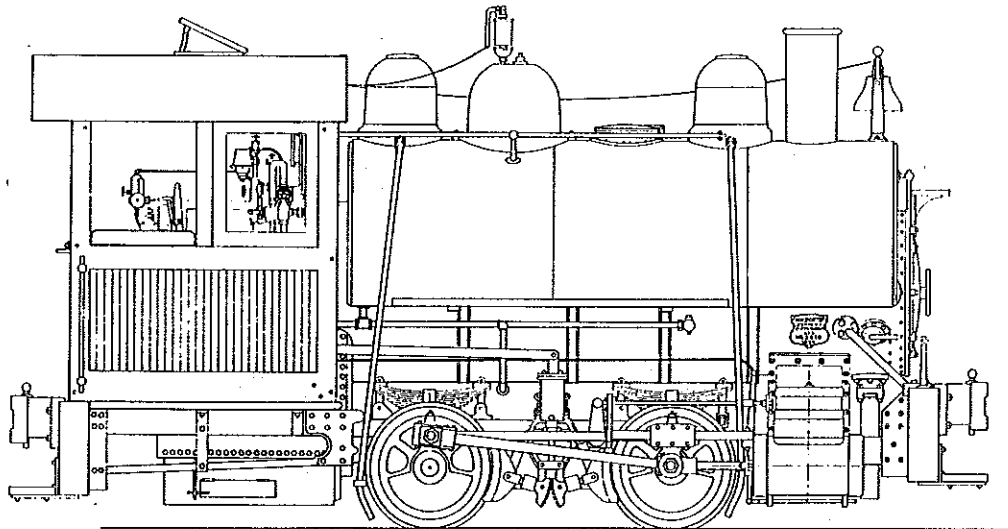

O_n3 KIT #3060

OVER 200 STYRENE, DELRIN^R, BRASS AND STEEL PARTS
SELF-QUARTERING DRIVERS, WITH STEEL RIMS AND AXLES

H.K. Porter Company specialized in light locomotives for industrial use for well over fifty years, manufacturing during their hey-day in the early 1900's over one every day. Most of these went to contractors, loggers and mining operations. These light locos (ten to thirty ton) helped many companies start in business at a reasonable cost. Later, as business improved, heavier locos were ordered and the little tea kettles were relegated to yard switching jobs.

We have selected the popular 18 ton, 36" gauge to model. We have modified the pilot beam to accommodate either link and pin couplers or MCB couplers at a height used by narrow gauge railroads commonly modelled.

H K Porter Company

18 TON 0-4-0-ST RECTANGULAR SIDE TANK LOCOMOTIVE

On3 KIT #3062

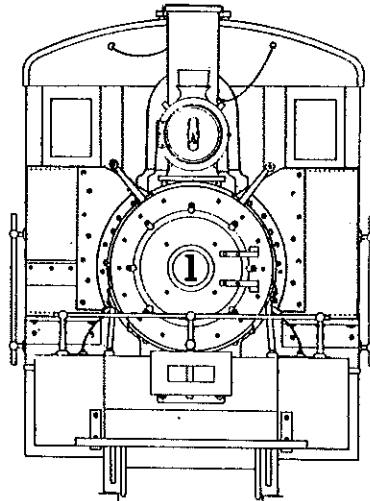
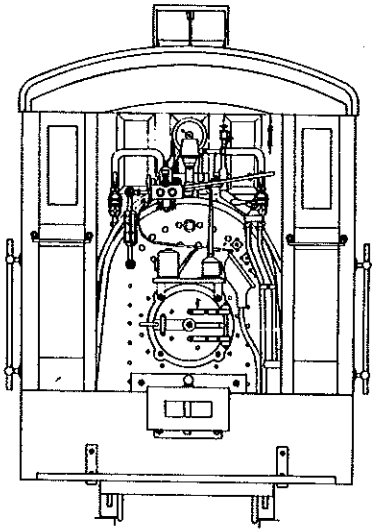
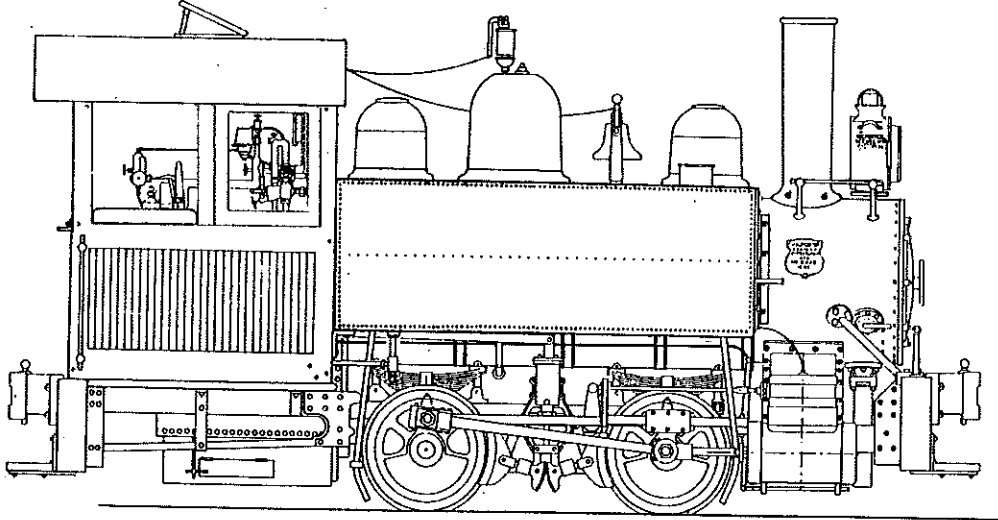

THE SAME QUALITY FEATURES AS OUR #3060
CAB DETAIL AND MOTORIZING KITS ARE AVAILABLE SEPARATELY

PORTER O-4-O Locomotive with Tender

Kit 3063

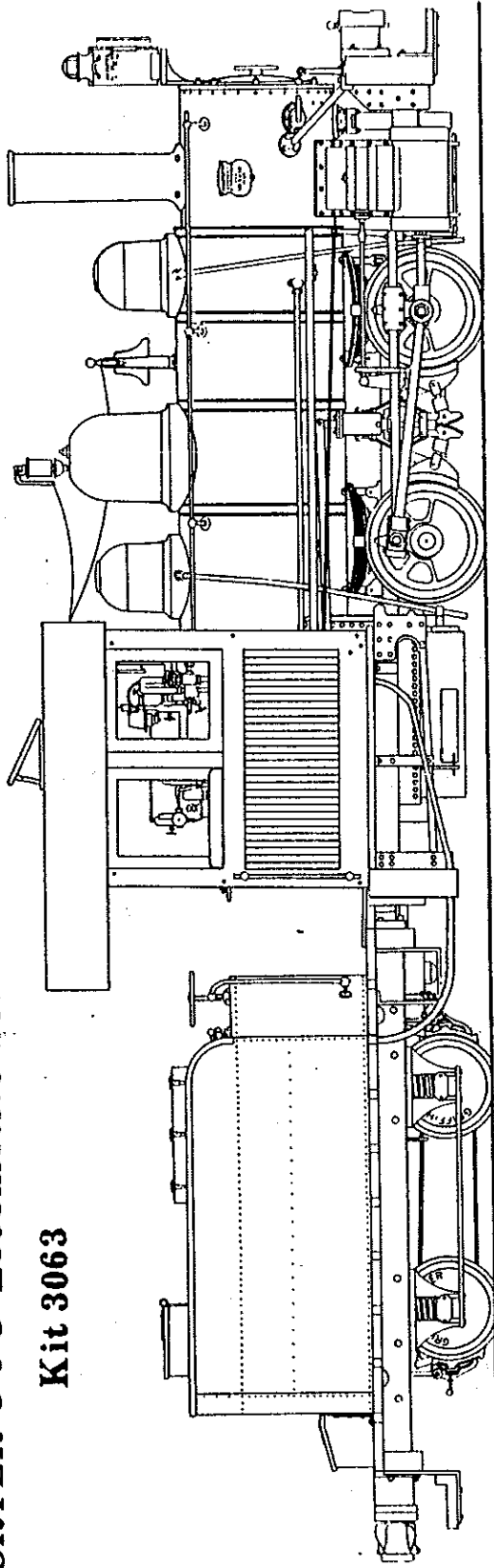

If the fuel and water capacity of the saddle tanks or side tanks was not enough for extended runs, a model with an auxiliary tender could be ordered from the Porter factory. This is the model which we have chosen for this kit. It had a 600 gallon, one ton coal capacity tender, omitting the tanks over the boiler and the fuel bunker in the cab. This arrangement reduced the weight of the loco from 18 to 15 tons, with (obviously) a reduction in tractive effort. The auxiliary tender could also be ordered for existing saddle or side tank locos if the fuel and water capacity of the loco was not enough for operating conditions. In this case, the water in the loco tank or tanks would add to the weight and tractive effort.

The popular 15 ton, 36" gauge is used for our model. We have modified the pilot beam to accommodate either link and pin couplers or MCB couplers at a height used by narrow gauge railroads commonly modelled. The styrene parts used are easily modified to suit your needs or favorite loco style.

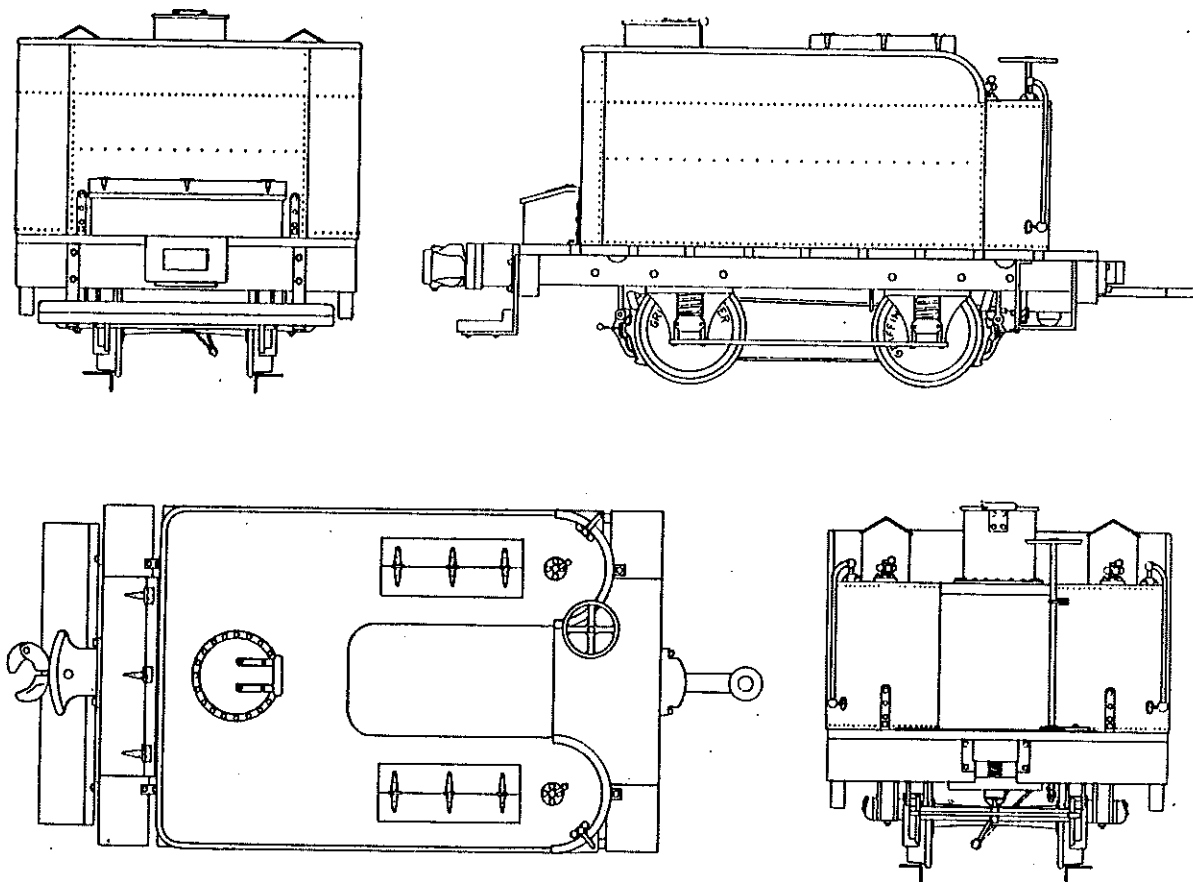

800 Gallon Auxiliary Tender for Porter 10 x 16 Locomotive

Kit 3064

Many users of small locos found that the water capacity of the saddle tanks and the fuel capacity of the small bunkers in the cab were not enough for a days work in the mines, quarries and lumbering operations. To solve this problem, they ordered an auxiliary tender from the manufacturer. Some operators made their own, as evidenced by pictures of locos in the various books that have been published, but H.K. Porter had available several sizes of tenders for "retro-fit". They also manufactured a series of "locomotives with tenders" in several sizes.

This kit represents a tender with a capacity of 800 gallons of water and 3,000 pounds of coal or 1-1/4 cords of wood fuel. It is of the four-wheel configuration.

H K Porter Company Four-Wheel-Connected Saddle-Tank Locomotive, Class B-S

For Contractors' Use, Shifting, and Special Services. Wide and Narrow Gauge.

H.K.Porter Co. specialized in light locomotives for industrial use for well over fifty years, manufacturing during their hey-day in the early 1900's over one every day., Most of these went to contractors, loggers and mining operations. These light locos (five to thirty ton) helped many companies start in business at a reasonable cost. Later, as business improved, heavier locos were ordered and the little tea kettles were relegated to yard switching jobs. One of the popular sizes of light locomotives was the 7" x 12" cylinder size. These could be ordered in many configurations from an O-4-0 wheel arrangement to O-6-0, Forneys and even steam dummies. The 7" x 12" cylinder O-4-0 wheel arrangement was carried as a stock item, while others were made to order. Locos could be ordered with different sized drivers, different couplers and coupler heights and in many gauges. 20", 24" 30", 36", 42", 48", 56-1/2", 60", 60cm, 75 cm and meter gauges are listed in the Porter Locomotive Co. records in just one year!

We have chosen the 8 ton, 36" gauge locomotive with 24" drivers as the basis for this kit. The styrene parts used are easily modified to suit your needs or favorite loco style. Parts are included for cab interior details. A cast metal engineer and a "lump" of chain are also supplied. You may model this locomotive in either of two periods: 1889 or 1900. Parts are supplied for either version. The 1889 version is shown in Figure B and the 1900 version in Figure A. Available separately is a custom-machined Micro-Mo 15:1 motor/gear box and gear tower kit. This is stock #7063.

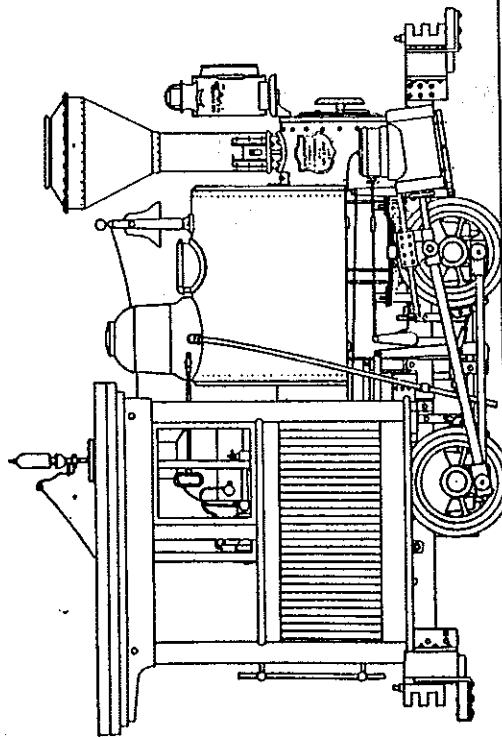

1900 VERSION

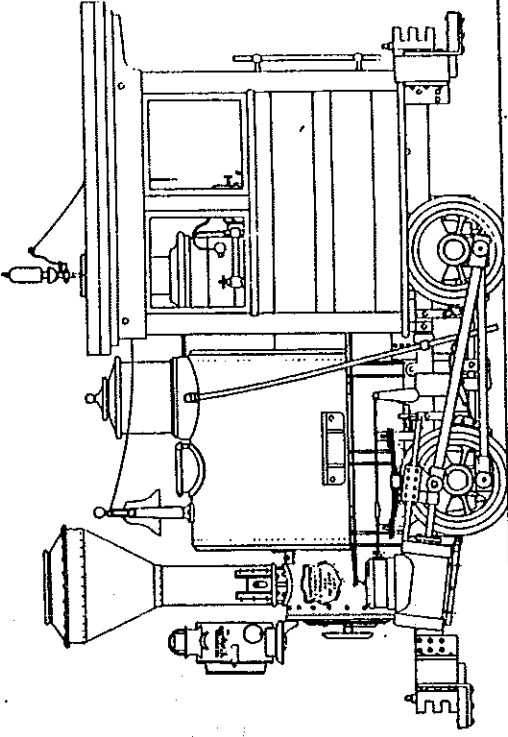
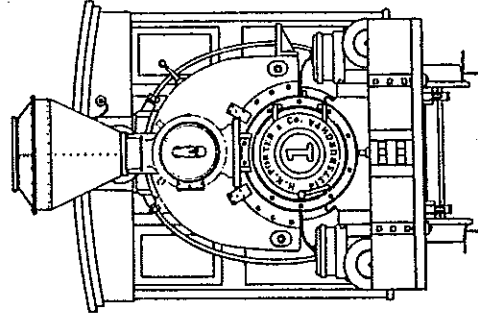

1889 VERSION

On3 KIT #3065 \$75.00
On30 KIT #3066 75.00

OVER 400 STYRENE, DELRIN®, BRASS AND STEEL PARTS
ASSEMBLED DRIVERS WITH NICKEL-PLATED STEEL RIMS AND AXLES

MICRO-MO DRIVE #7063 75.00

PORTER STEAM DUMMY

ADAPTING KIT FOR OUR 8 TON PORTER KIT #3065

AVAILABLE IN ON3 ONLY---KIT #3067

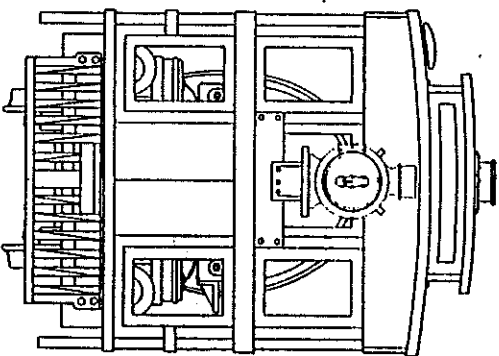
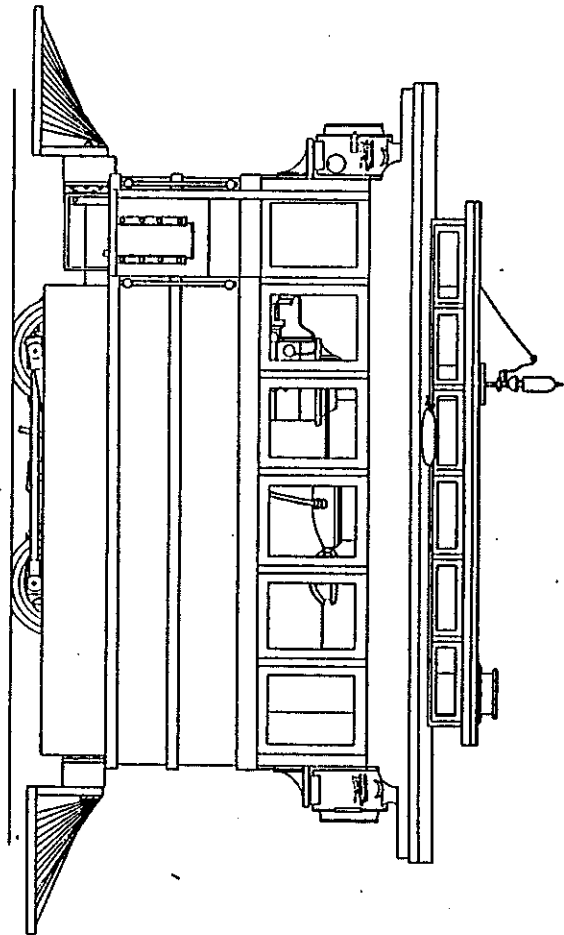

GRANDT LINE PRODUCTS

1040 B SHARY CT CONCORD, CA 94518 (510) 671-0143 FAX 671-0806

PLYMOUTHS...PLYMOUTHS...PLYMOUTHS...PLYMOUTHS

GRANDT LINE HAS THE INDUSTRIAL LOCO YOU'VE BEEN LOOKING FOR IN 1/4" SCALE

PLYMOUTH FL1 FIVE TON GAS-MECHANICAL INDUSTRIAL LOCOMOTIVE Plymouth F Series locos were made in the 1920's to replace steam locos in quarries, steel mills, brick yards, logging operations, cranberry bogs, salt evaporation plants and other industrial plants, as well as (without cabs) in mines. Most common gauges were 2-foot and 3-foot. These locos are motored by Machima M19CF 5-pole motors which fit entirely inside the hood, enabling full detailing of the cab area. Kits include all necessary parts, including cab details.

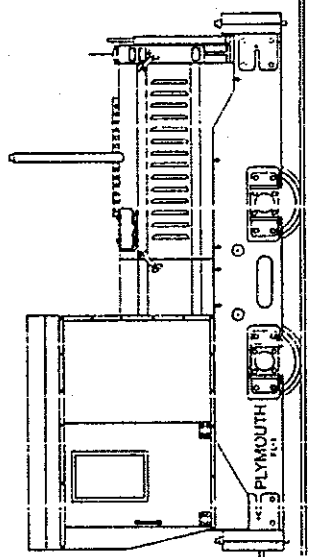
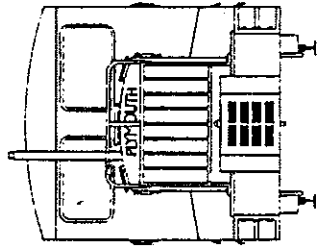

36" GAUGE KIT # 7061 \$45.00

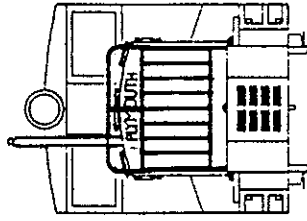
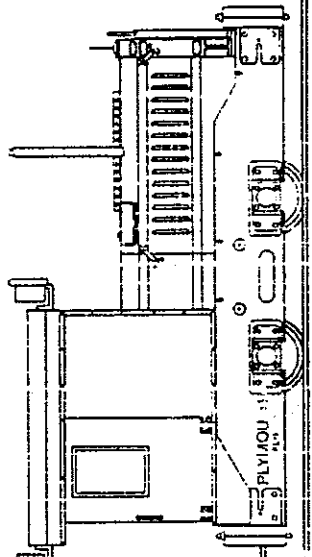
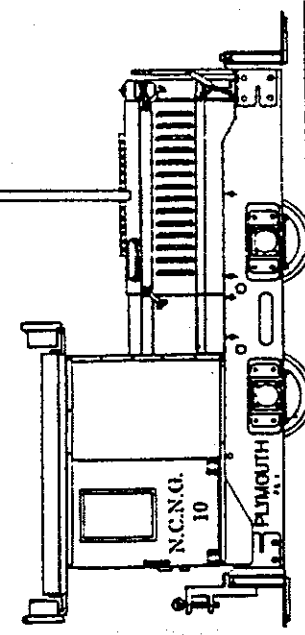

36" GAUGE NEVADA COUNTY NARROW GAUGE KIT # 7058 \$50.00

30" GAUGE KIT # 7059 \$45.00

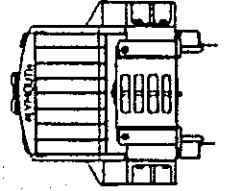
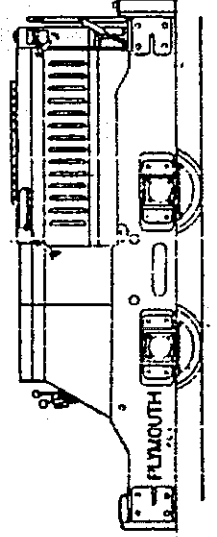
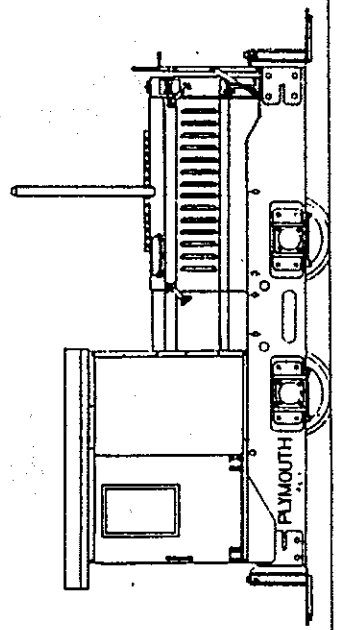

24" GAUGE KIT # 7061 (CAN BE BUILT WITH OR WITHOUT CAB) \$45.00

C&S / RGS STEEL UNDERFRAME STOCK CAR

- INJECTION MOLDED THROUGHOUT
- DELRIN TRUCKS AND COUPLERS
- BETTENDORF UNDERFRAME
- MURPHY ROOF
- COMPLETE UNDERBODY DETAIL
- NON-MAGNETIC WHEEL SETS
- OPERATING DOORS
- OVER 100 PARTS

In 1910, 70 stock cars were built by the Colorado & Southern RR from parts manufactured for them by the Bettendorf Axle Co. Featuring steel underframes and cast steel trucks, these cars were the most modern narrow gauge freight cars to appear on the Colorado scene until the early 1940's. Upon the demise of the C&S in 1938, 34 cars were sold to the R.G.S. They were a common sight in stock trains on both the R.G.S. and D.&R.G.W. until scrapped in 1952. A few stock cars were sold by the C&S to the White Pass & Yukon in 1942 where, although converted to flat cars, the underframes continued in daily use until the mid-1970's.

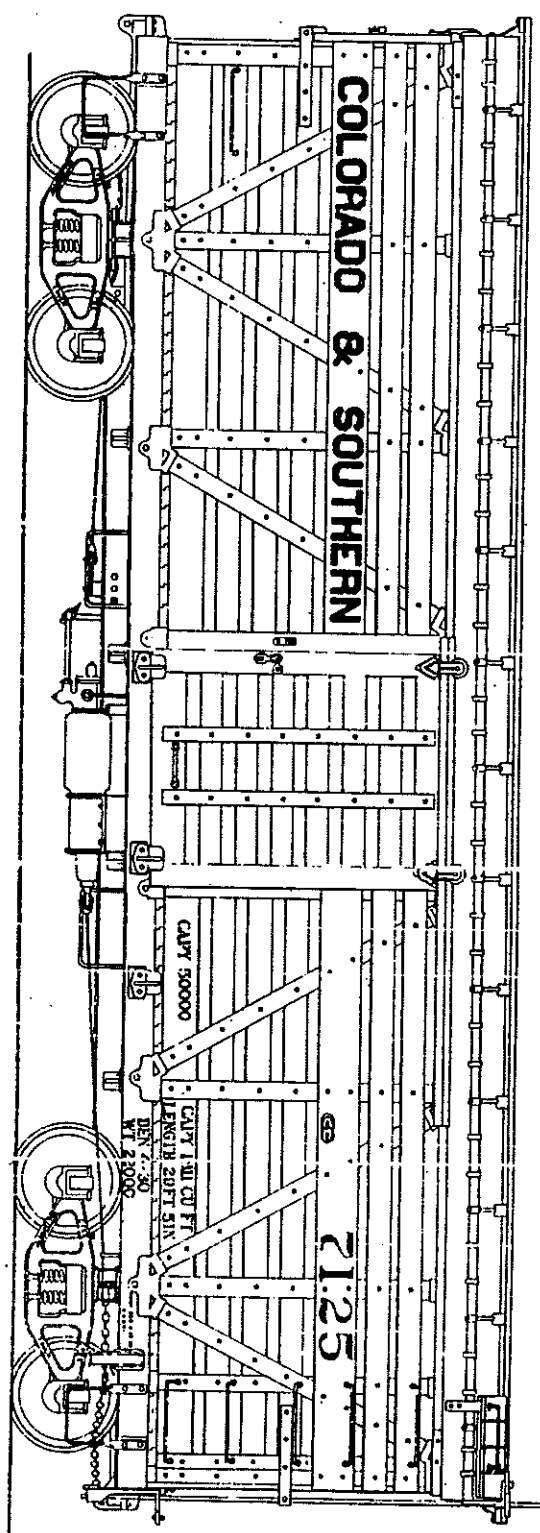
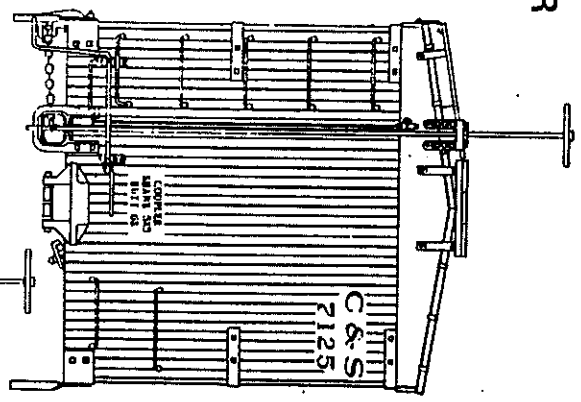
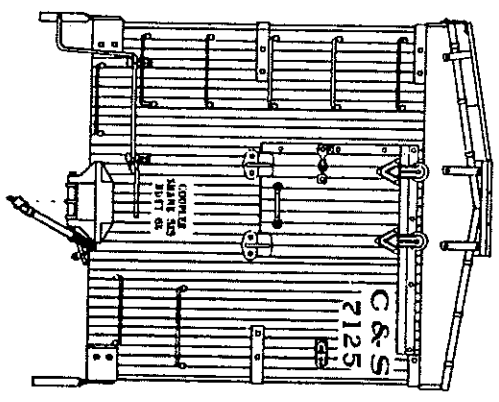

On3 KIT #3059

C & S Caboose # 1006

On3 KIT #3071

This kit is based on Colorado & Southern #1006, which is currently on display at Silver Plume, Colorado. All dimensions of the model are based on detailed measurements of the present caboose, as well as drawings, photos and information from some of the most trusted names in model railroading. We have tried to reproduce the caboose as it was in service, with allowances for manufacturing processes and modeling requirements.

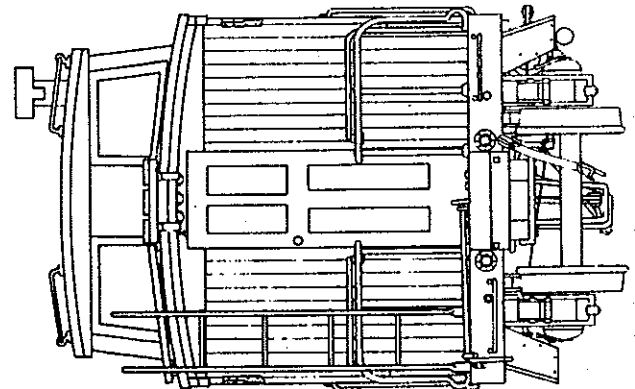
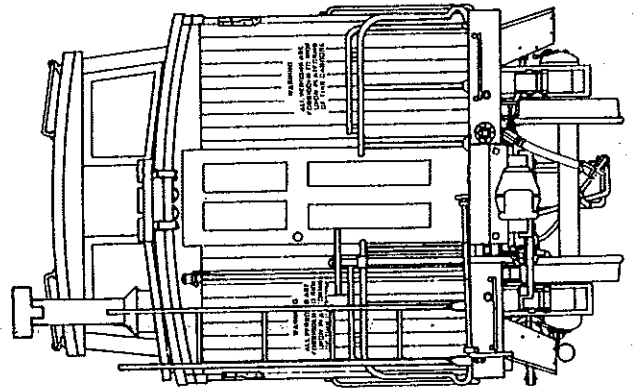
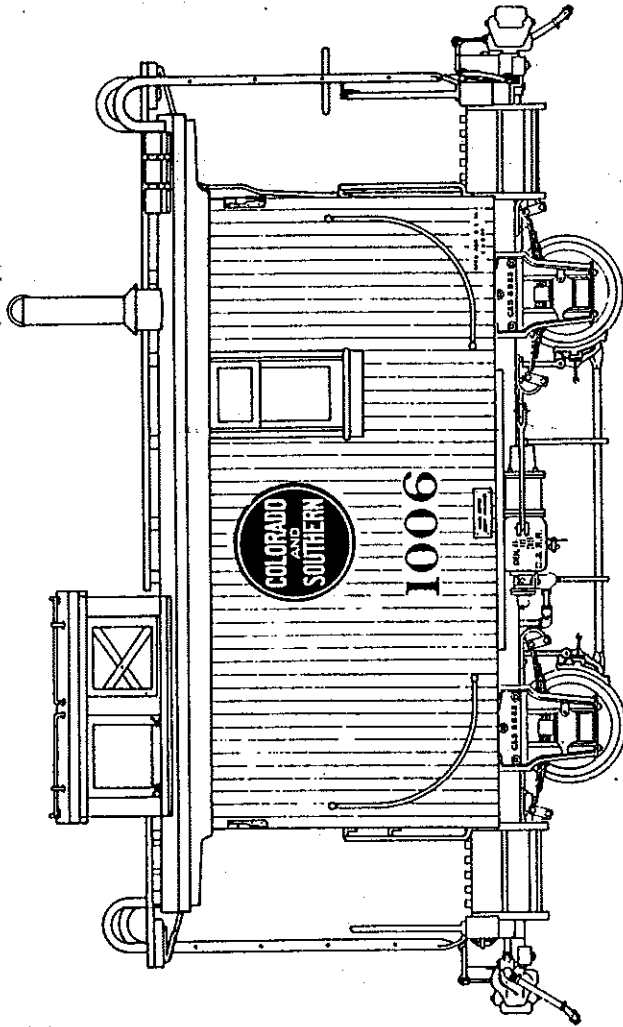

FEATURES

- Injection molded throughout
- Over 100 Styrene, Delrin[®], Brass and phosphor-bronze Parts
- Delrin[®] Bearings and Couplers
- Non-magnetic Wheelsets
- Complete Underframe Detail
- Underframe Will Accept New Kadee On3 Couplers

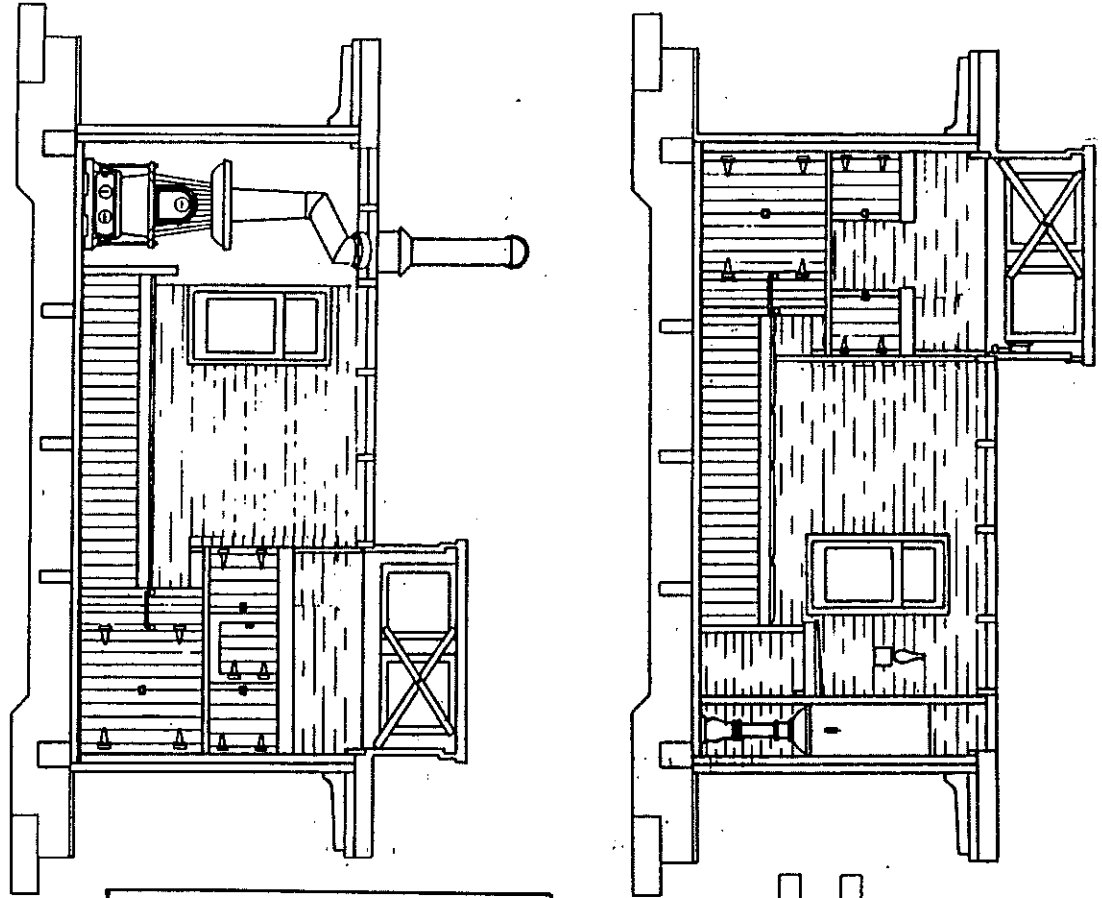

DETAIL KIT FOR
C&S CABOOSE #1006
 complete interior
 injection molded plastic
 includes:
 stove, bunks, cushions
 cabinets, seats, sink
 air gauge, desk, lamp
 water cooler, coffee boiler
KIT #3069

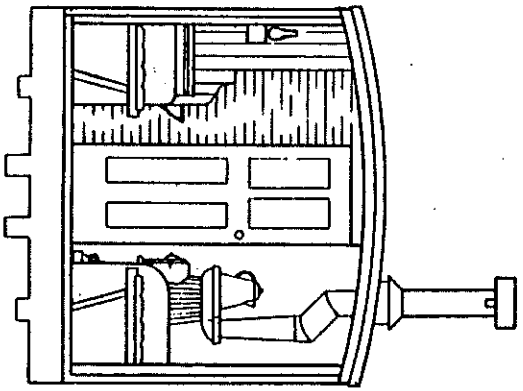
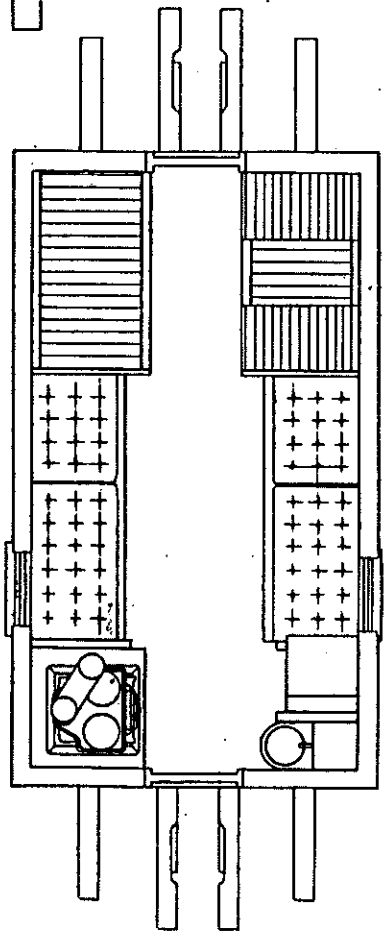

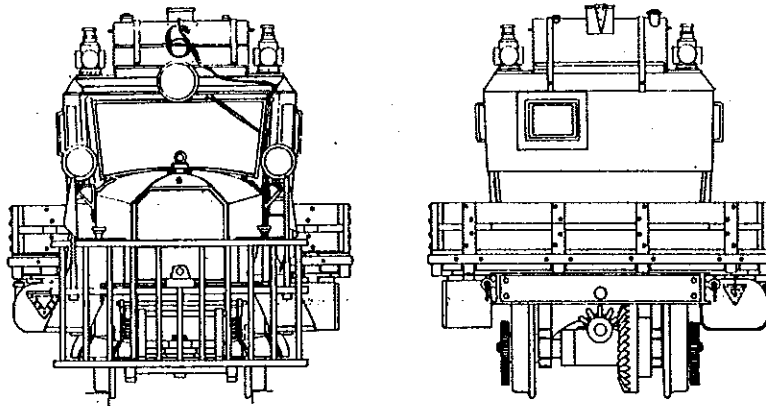
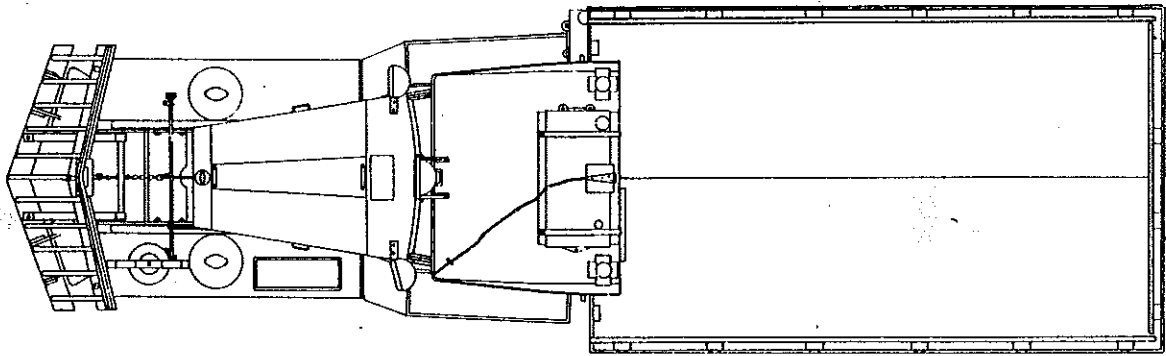
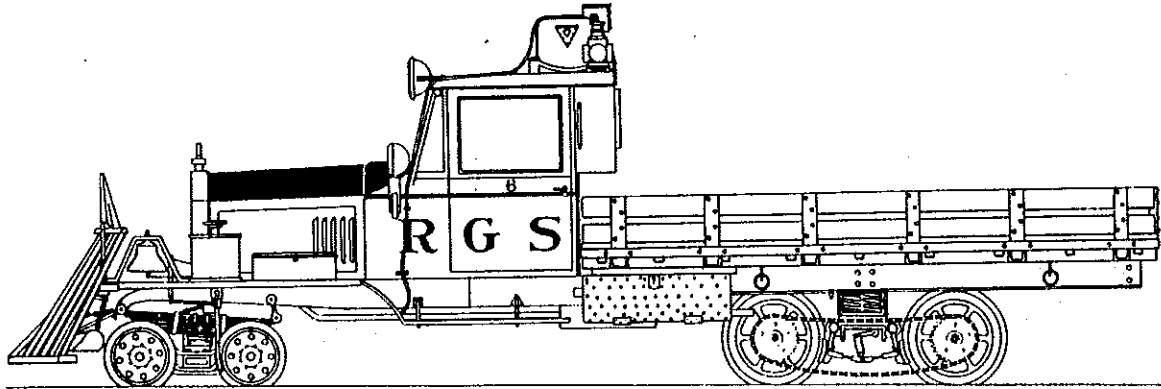

RGS Work Goose No.6

On3 KIT #3081

FEATURES:

- INJECTION MOLDED IN STYRENE AND DELRIN
- MICRO-MO MOTOR CONCEALED IN CAB, LEAVING BED EMPTY
- CAST METAL "DRIVER" INCLUDED
- FRONT TRUCK PRE-ASSEMBLED
- REAR TRUCK WITH GEARING AND DUMMY CHAIN PRE-ASSEMBLED

D & RGW

Drop-bottom Gondola

800 Series

KIT #3072 IN On3

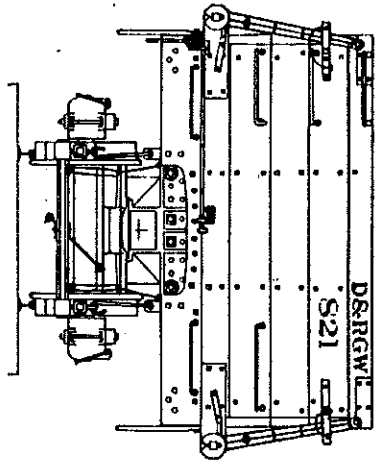

- ** OVER 100 PARTS
- ** INJECTION MOLDED THROUGHOUT
- ** DELRIN[®] TRUCKS AND COUPLERS
- ** COMPLETE UNDERBODY DETAIL
- ** NON-MAGNETIC WHEELSETS
- ** THIN-FILM DECALS

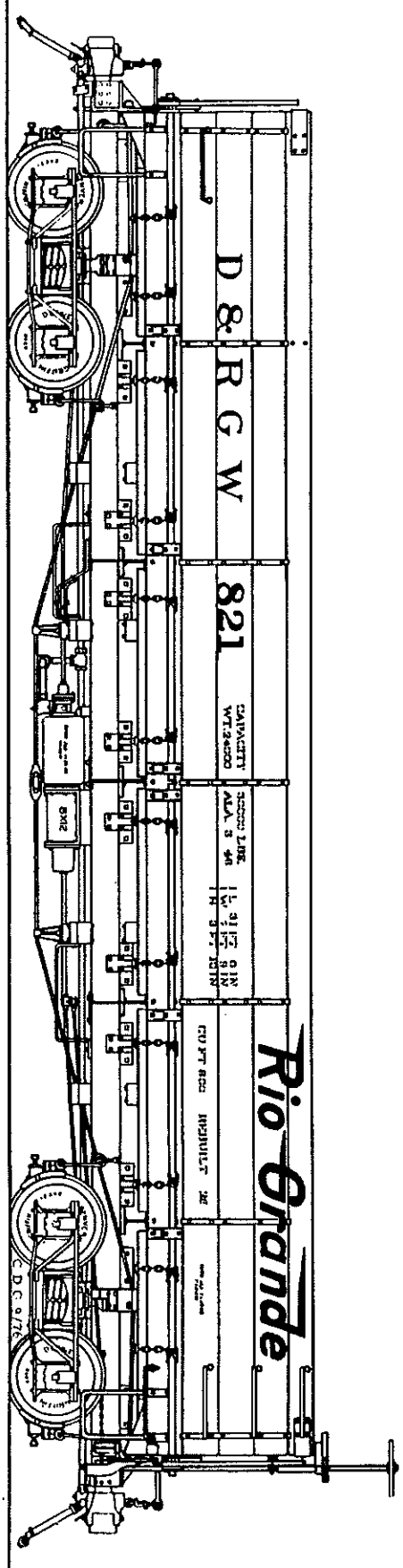
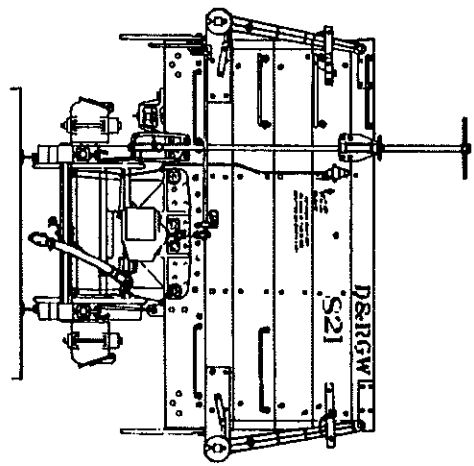

700 Series D & RGW

Drop-bottom Gondola

- ** OVER 100 PARTS
- ** INJECTION MOLDED THROUGHOUT
- ** DELRIN[®] TRUCKS AND COUPLERS
- ** COMPLETE UNDERBODY DETAIL
- ** NON-MAGNETIC WHEELSETS
- ** THIN-FILM DECALS

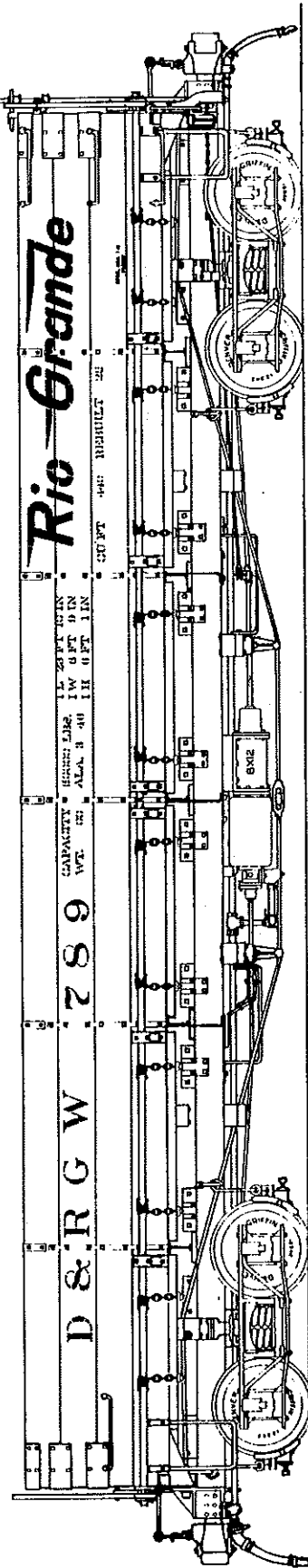
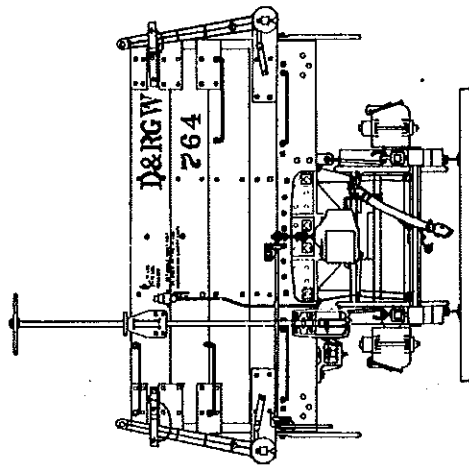
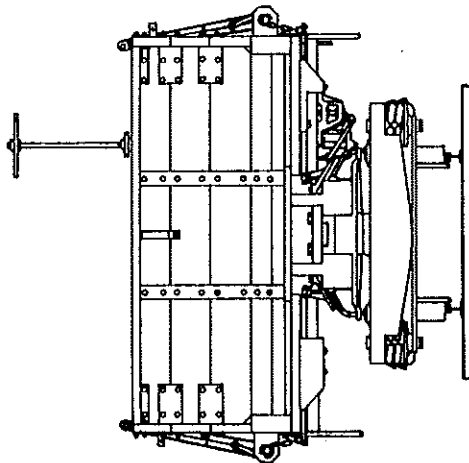

KIT #3051 IN On3

Colorado & Southern Gondola Steel Underframe

Kit 3105

- ** DELRIN TRUCKS AND COUPLERS
- ** BETTENDORF STEEL UNDERFRAME
- ** COMPLETE UNDERBODY DETAIL
- ** NON-MAGNETIC WHEELSETS

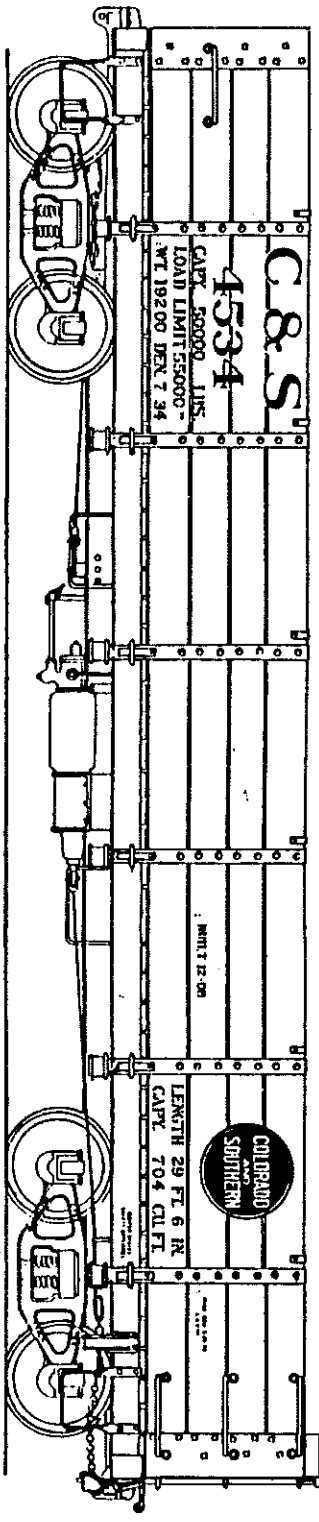
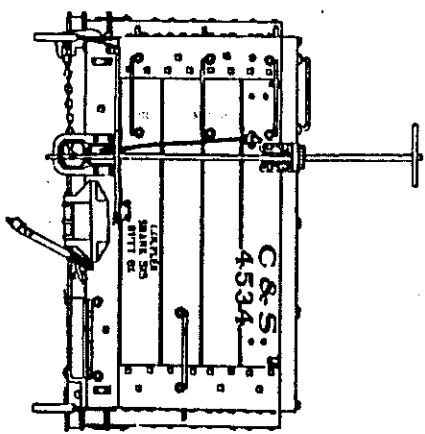
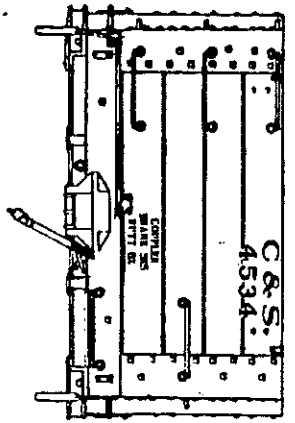

KIT # 3105 IN ON3 JUST \$37.50

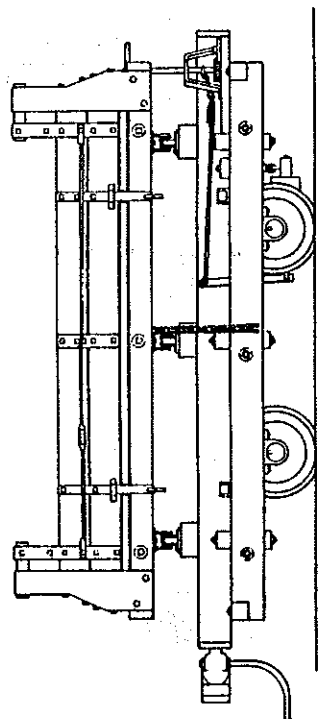

FIGURE 1: Side View

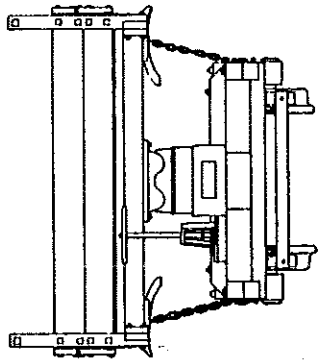

FIGURE 2: End View

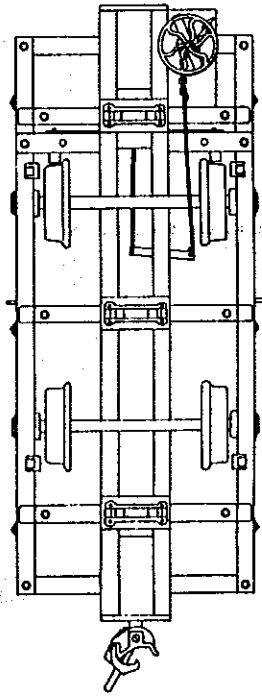

FIGURE 3: Top View--Frame

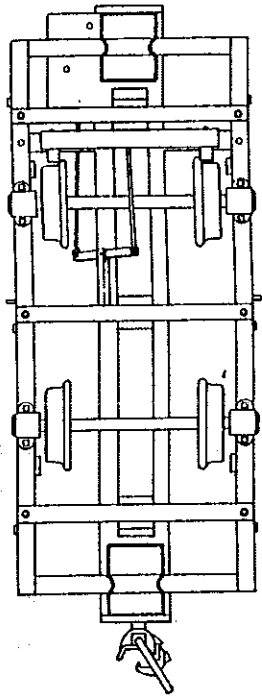

FIGURE 4: Bottom View--Frame

FAIRBANKS-MORSE #37 DUMP CAR On3 KIT #3103

This kit is easily assembled in either a static or operating model, and is designed to use Kadee #5 HO couplers, which scale out to just about right for a mining coupler. Wheels can be easily pushed in on their axles to 30" (HO) gauge. This is an appropriate car to be hauled by our 18 ton Porter.

FEATURES:

- Injection molded throughout in styrene and Delrin®
- Non-magnetic wheelsets
- Will accept Kadee® couplers
- Can be made Operable

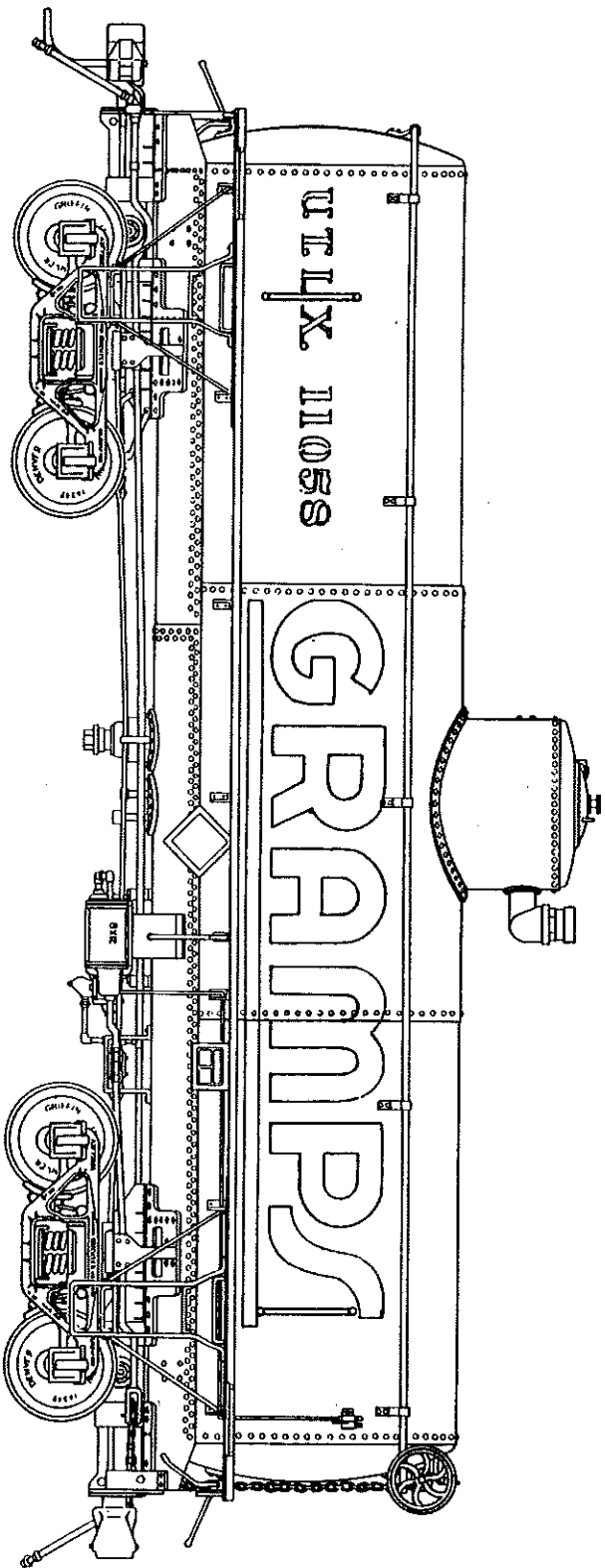

UTLX Frameless Tank Car

On3 KIT #3079





FEATURES:

- Injected molded throughout
- Over 75 styrene and Delrin® parts
- Delrin® bearings and couplers
- Non-magnetic wheelsets
- Complete underbody detail
- Thinfilm™ decals
- Underframe will accept new Kadee On3 couplers

Our kit is for the basic UTLX Class VV Narrow Gauge Van Dyke tank car, as used after the 1956 renumbering. We have included some extra hardware, so that some variations may be made. A few parts are also included for a Class V car. To construct one of these cars, however, it will be necessary for you to purchase a few additional parts: brake cylinder (GL Part #97), additional piping (Part #112) and a strip of brass, .015"x.030".

ALL SCALE CONSTRUCTION MATERIALS

PLASTIC RODDING

Part #	12" Long Pieces	Diameter	Prototype Sizes			
			"O"	"S"	"HO"	"N"
3901		.010	1/2"	5/8"	7/8"	1-5/8"
3902		.020	1	1-1/4	1-3/4	3-1/4
3903		.030	1-1/2	2	2-5/8	4-3/4
3904		.040	2	2-9/16	3-1/2	6-1/2
3905		.050	2-1/2	3-1/4	4-7/8	8

PLASTIC SHIP MODEL HATCH GRATINGS

.050"
sq. holes

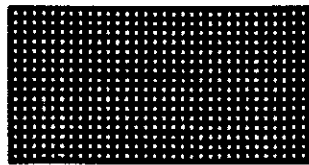

3907 2/1.25

.100"
sq. holes

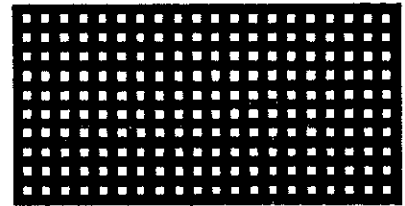

3906 2/1.25

SCREWS

#7087
Delrin Screw Asst
2-56, 2 mm, 0-80

9

ARCHITECTURAL PARTS

DOORS & WINDOWS

O
1:48
O
1:48
O
1:48
O
1:48
O
1:48
O
1:48
O
1:48
O
1:48
O
1:48
O
1:48
O

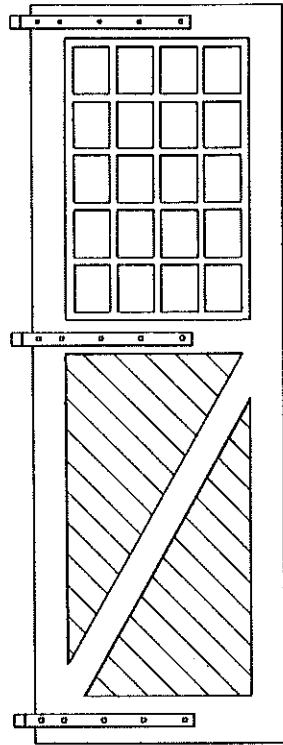

Engine House Door
5'2" x 15'3"
with Hinges
#3609

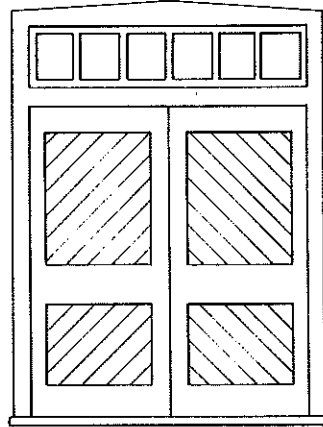

Freight Doors
6' x 82"
#3618

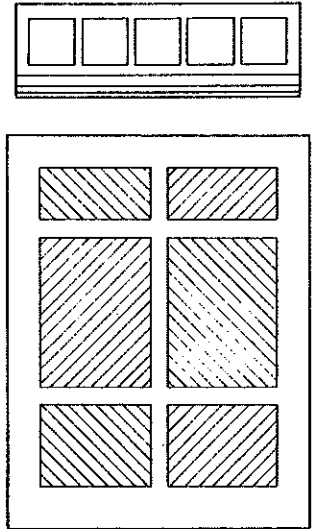

Freight Door
with Transom
72" x 96"
RGS
#3621

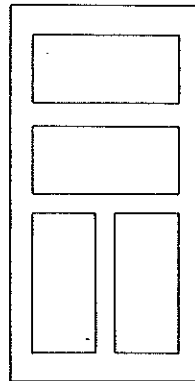

D&RGW Baggage Doors
48" x 94"
Sargents Station
#3607

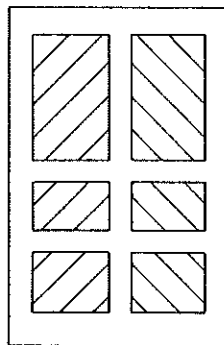

D&RGW Baggage Doors
55" x 85"
Sargents Station
#3606

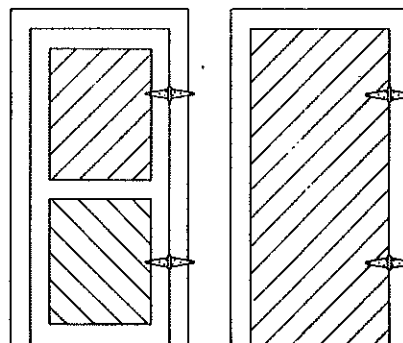

35" Shed Doors
Diagonal Sheathed
#3610

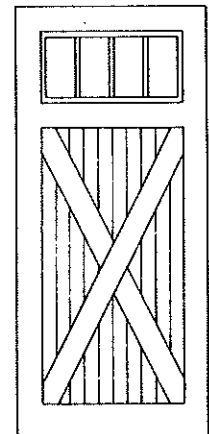

Freight Doors--Double
4' x 9'
with window
#3611

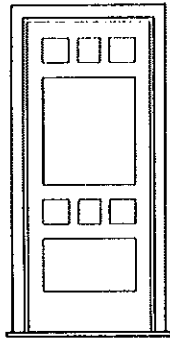

30" Door with Window
Separate Frame
#3601

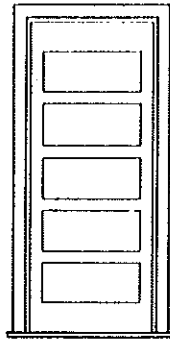

30" Door
Separate Frame
#3602

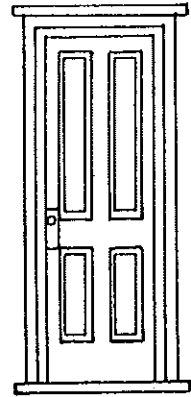

36" Station Door
D&RGW
#3619

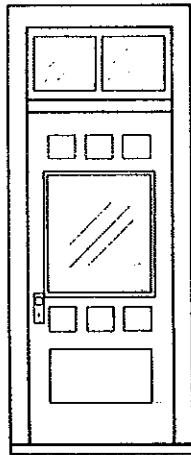

Depot Door
with Window, Transom
36" x 84"
RGS
#3620

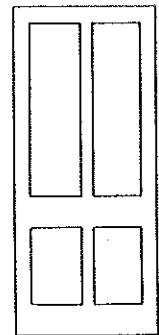
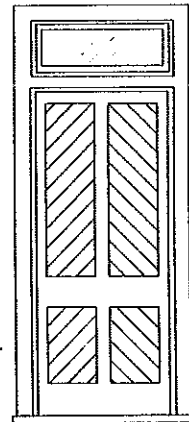
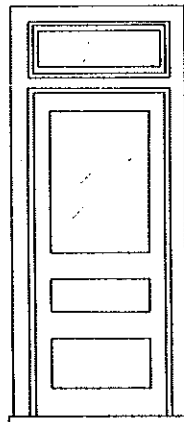

D&RGW Waiting Room Doors
Separate Frame
#3608

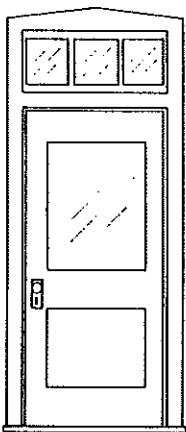

Office Doors
36"
#3617

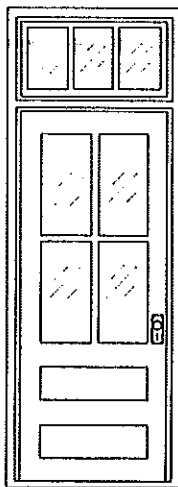

Factory Front Door
39" x 92"
for Masonry Building
#3612

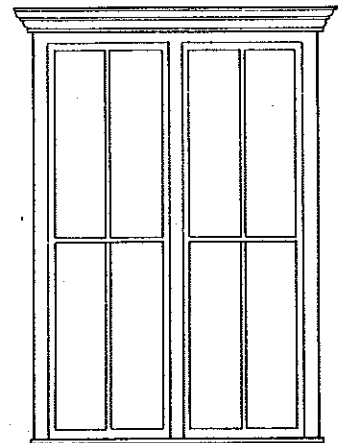
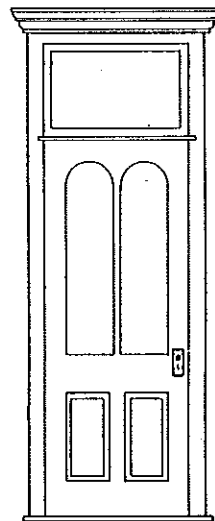

Store Front Door, Window
#3513

10-1

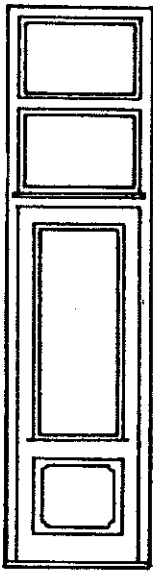

Commercial Storefront
Single Door
#3626
formerly Gould #1015

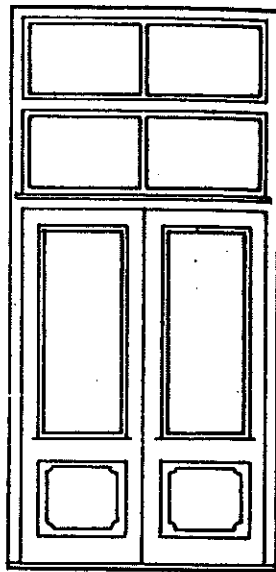

Commercial Storefront
Double Door
#3627
formerly Gould #1001

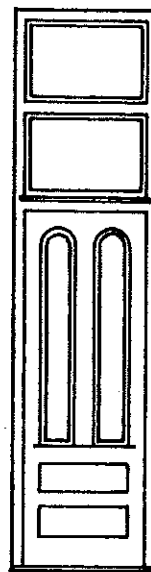

Commercial Storefront
Single Door
#3625
formerly Gould #1017

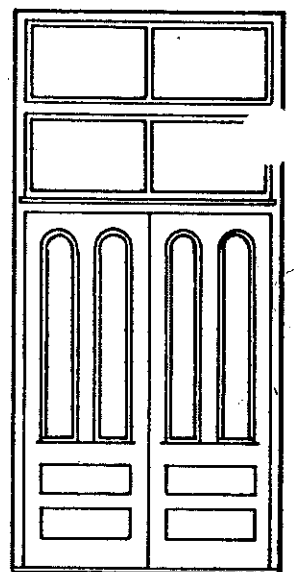

Commercial Storefront
Double Door
#3624
formerly Gould #1016

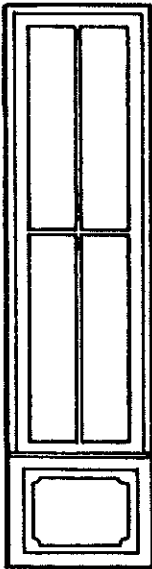

Commercial Storefront
Single Window
#3735
formerly Gould #1018

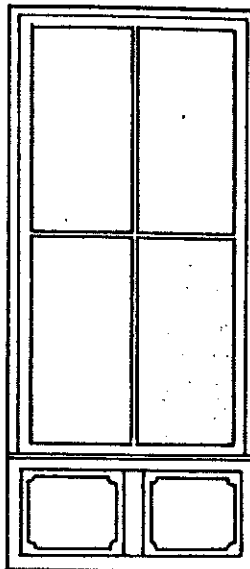

Commercial Storefront
Double Window
#3734
formerly Gould #1002



Window Spacer Post
(use to combine
storefront series)
#3538
formerly Gould #1006

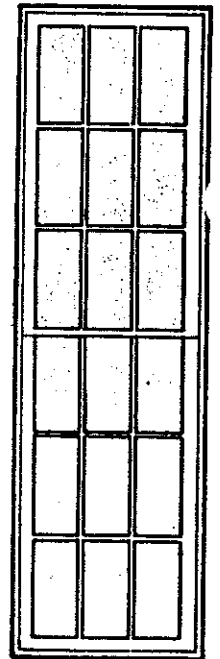

Masonry Window
Double Hung
#3740
formerly Gould #1010

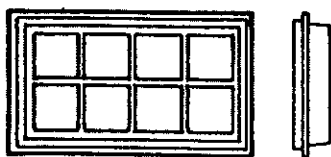

Recessed Window
or Skylight
#3737
formerly Gould #1013

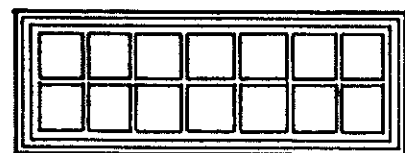

Recessed Window
or Skylight
#3738
formerly Gould #1012

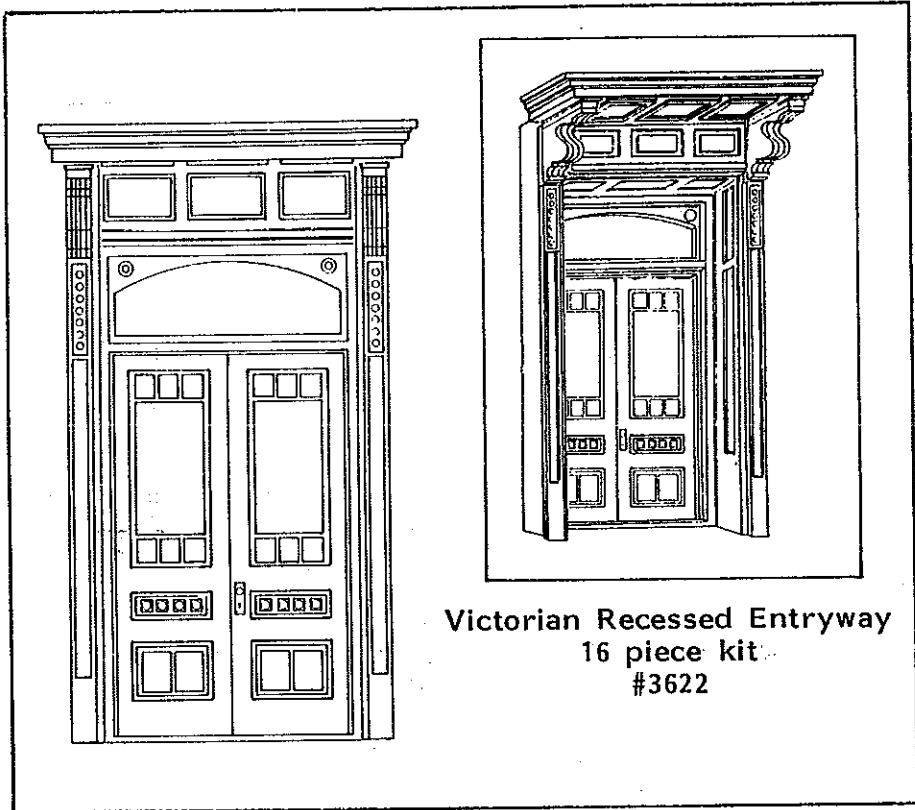

Victorian Recessed Entryway
16 piece kit
#3622

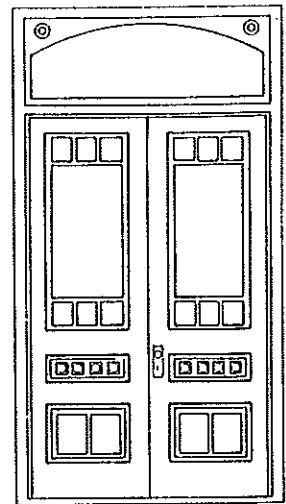

Victorian Entry Door
with Transom
for Masonry Buildings, etc.
#3623

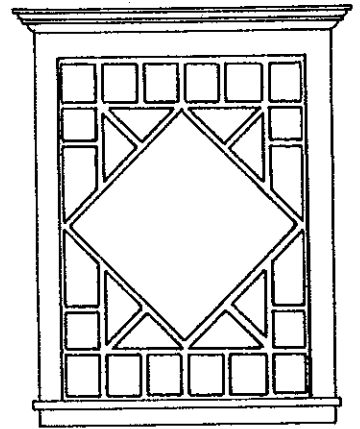

Diamond Patterned Window
#3743

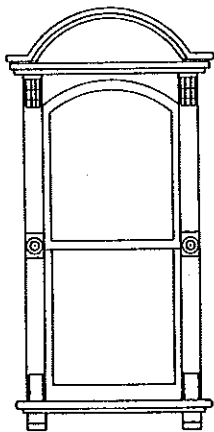

Victorian Window
with Arched Pediment
#3732

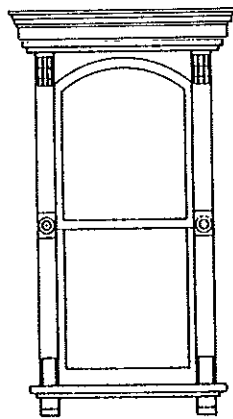

Victorian Window
with Flat Box Pediment
#3733

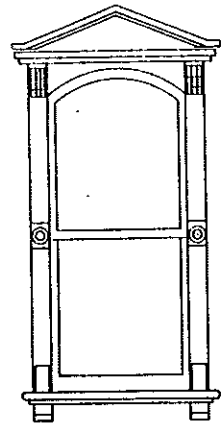

Victorian Window
with Triangular Pediment
#3731

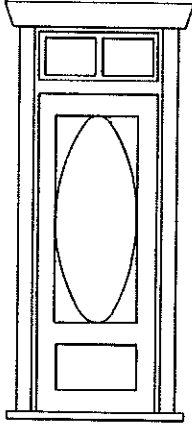

30" Residence Door
Separate Frame, Transom
#3605

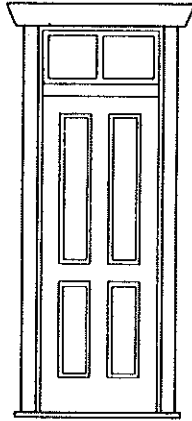

30" Station or House Door
Separate Frame, Transom
#3603

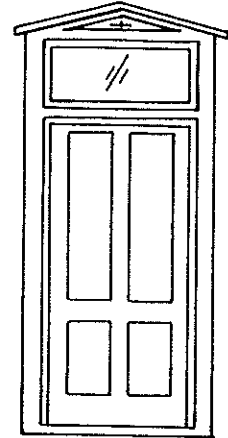

36" Durango Station Door
Separate Frame, Transom
#3604



Single Door with Frame
4'2" x 9'7"
#3613

Iron Shutters
to fit over #3613
#3614

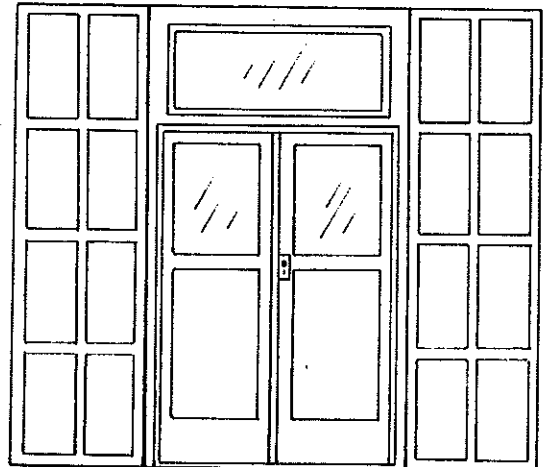

Double Door with Frame
5'5" x 9'7"
#3615

Iron Shutters
to fit over #3615
#3616

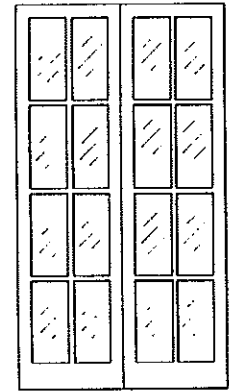
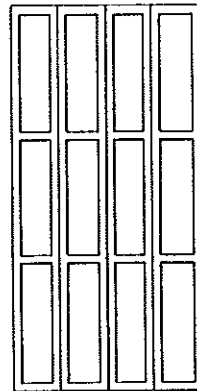
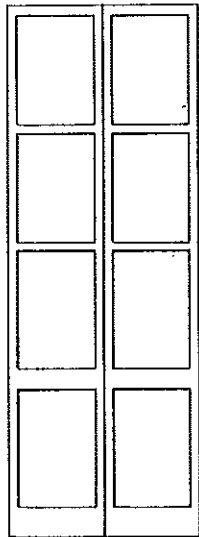
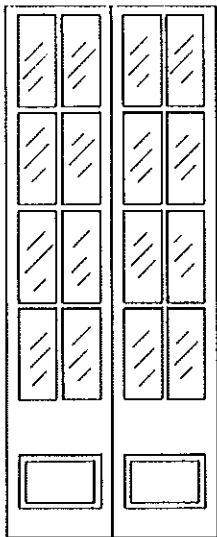

Front Door, Shutter
Wells Fargo
#3502

Balcony Door, Shutter
Wells Fargo
#3503

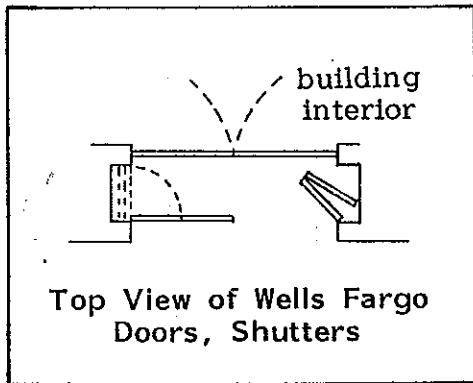

Top View of Wells Fargo
Doors, Shutters

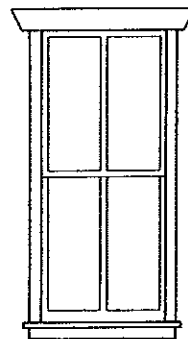

Station Window
4 Pane, 30" x 69"
#3706

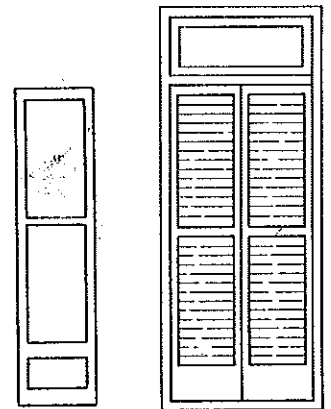

Balcony Doors, Shutters
for Masonry Building
#3506

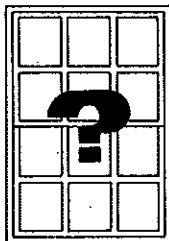

Window Grab Box
Box filled with assorted
Grandt Line windows
(assortment varies, according
to what stock may be on hand)
#3741

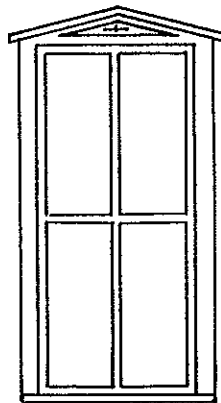

Station Window
4 Pane, 36" x 87"
Durango Station
#3709

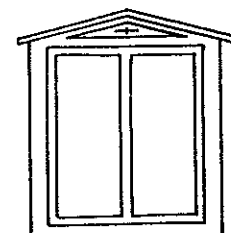

Station Window
2 Pane, 36" x 44"
Durango Station
#3710

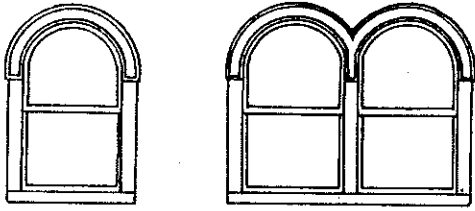

Double Hung Windows
Arched Top
#3746

Pkg. includes:
2 Double Windows
4 Single Windows

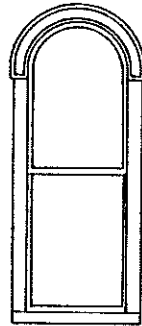

Double Hung Window
Arched top, 2 Pane
#3745

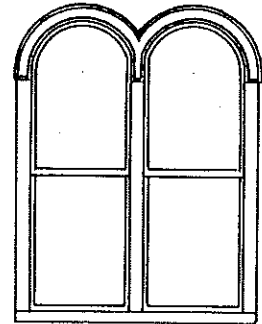

Double Hung Window
Double-arched Top, 4 Pane
#3744

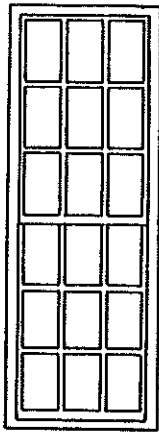

#3747

Masonry Window
double hung
104" x 37-1/2"

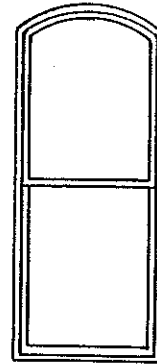

#3748

Masonry Window
double hung
round-top
36" x 90"

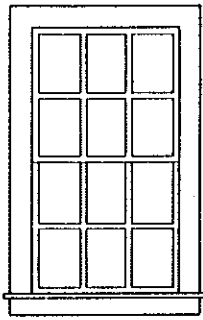

Double Hung Window
12 Pane, 36" x 64"
#3701

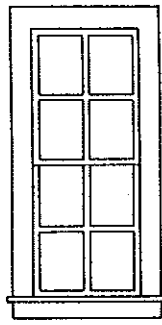

Double Hung Window
8 Pane, 27" x 64"
#3703

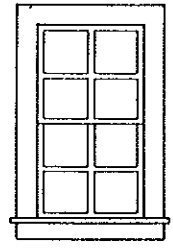

Double Hung Window
8 Pane, 27" x 48"
#3702

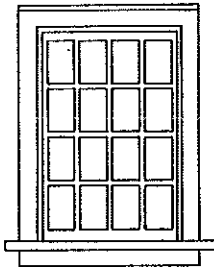

Double Hung Window
16 Pane, 36" x 56"
#3707

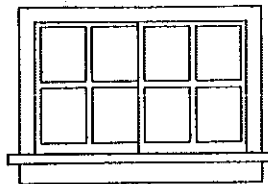

Horizontal Sliding Window
8 Pane, 52" x 33"
use for camp cars, shacks,
work cars, etc.
#3713

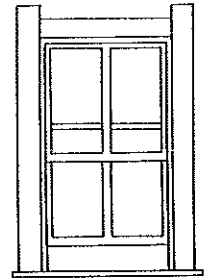

Double Hung Window
4 Pane, 31" x 56"
Operating Sash
Sargents Station
#3711

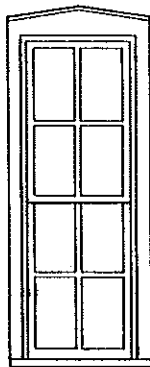

Double Hung Window
8 Pane, 36" x 70"
#3721

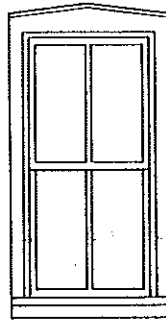

Double Hung Window
4 Pane, 33" x 65"
#3720

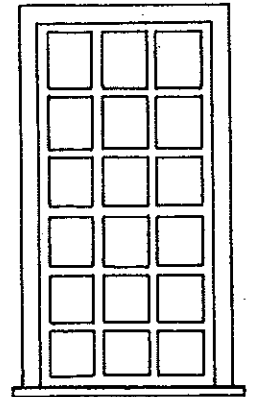

Engine House Window
18 Pane, 42" x 91"
#3714

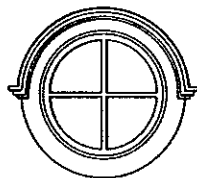

Attic Window
30" Round
Silverton Station
#3708

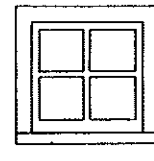
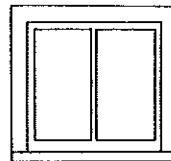

Single Sash Attic Windows
4 Pane, 28" x 28"
2 Pane, 34" x 32"
#3722

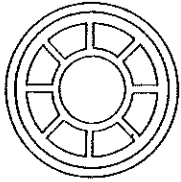

Window for Masonry Building
9 Pane, 42" Round
#3716

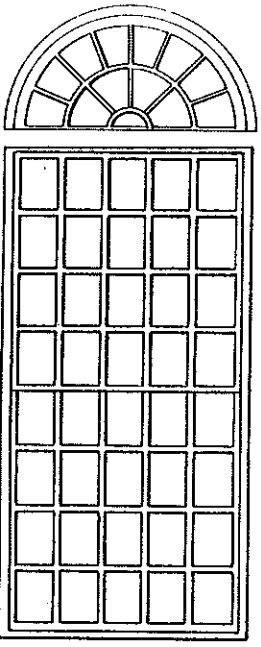

Round Top Window
53 Pane, 5' x 12'6"
#3715

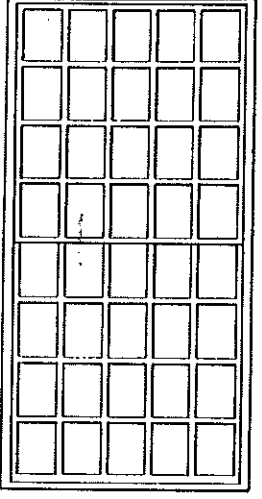

Roundhouse Window
40 Pane, 60" x 120"
#3705

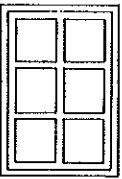

Fixed Sash Factory Window
for Masonry Building
6 Pane, fits opening 42" x 30"
#3719

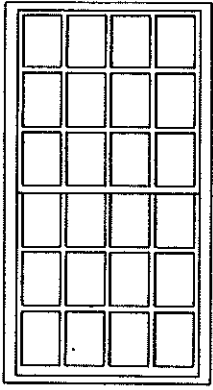

Engine House Window
24 Pane, 48" x 96"
Rico
#3712

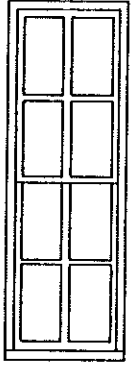

Masonry Window
(lower sash can be
placed in open
position if desired)
#3730

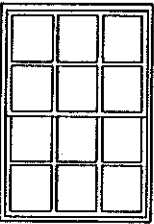

Double Hung Window
12 Pane, 36" x 56"
#3704

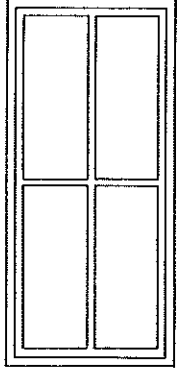

Double Hung Factory Window
for Masonry Building
4 Pane, fits opening 42" x 91"
#3717

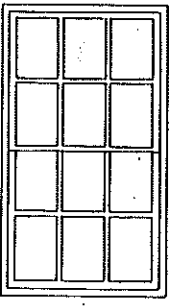

Double Hung Factory Window
for Masonry Building
12 Pane, fits opening 42" x 72"
#3718

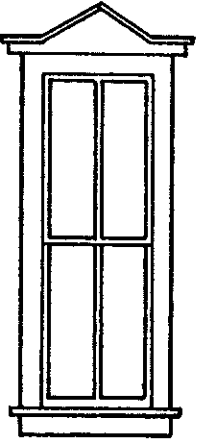

Double-hung Window
4-pane
#3736

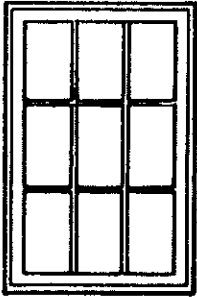

Masonry Window
#3739
formerly Gould #1011

RGS STYLE DEPOT WINDOWS

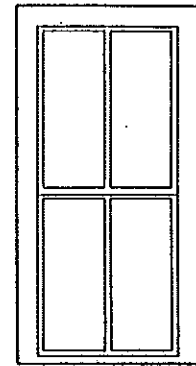
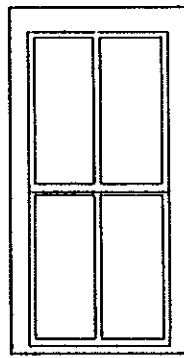
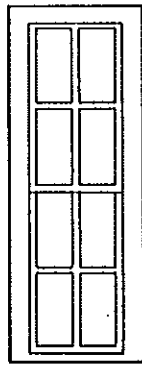
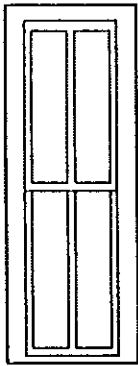

4 Pane, 24" x 82"
8 Pane, 24" x 82"
#3729

4 Pane, 36" x 80"
#3724

4 Pane, 36" x 82"
#3723

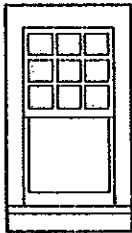

10 Pane, 24" x 44"
#3726

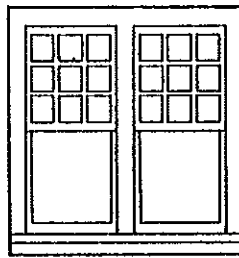

20 Pane, 51½" x 51"
Double
#3728

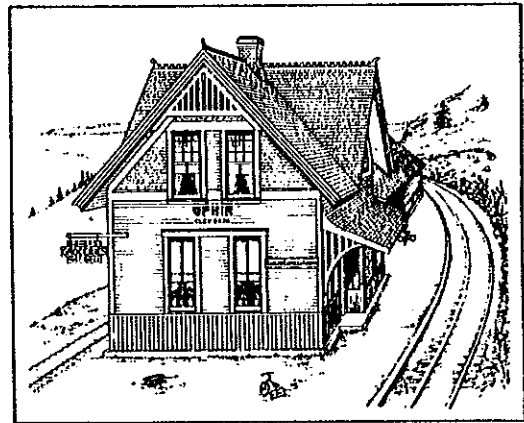

Ophir/Dolores Depot Set
contains parts #3729, 3726
3723, 3725, 3724
3728, 3620, 3621, 3028
3521, 3522, 3523
#3520

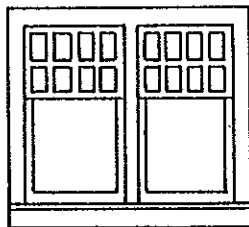
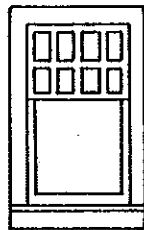

RGS Style Depot Windows
32" x 52", 9 pane
72" x 82", 18 pane
3742:

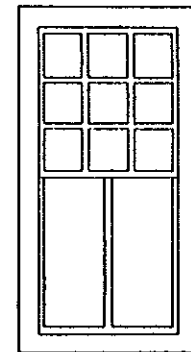

11 Pane, 36" x 76"
#3725

STRUCTURAL DETAILS

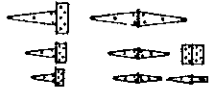

Barn Door Hinge Asst
#3508
in brass, #2125

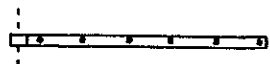

#3553

Engine House Door Hinges

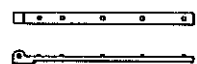

Engine House Door Hinges
#3524

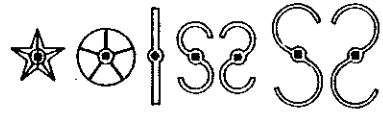

Ornamental Washers, Nuts
for Masonry Buildings
#3507

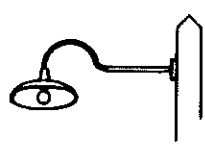

Lamp Reflectors
(will fit Micro-lites)
#3510

Lamp Reflectors in brass
with bulbs
#1084

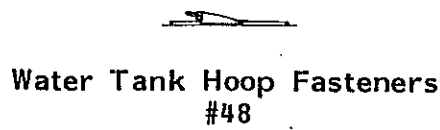

Water Tank Hoop Fasteners
#48



Electrical Meter
w/ Switch Boxes
#3534
formerly Gould #1004



Building Date Plaques
w/ Numbers
#3532
formerly Gould #1005

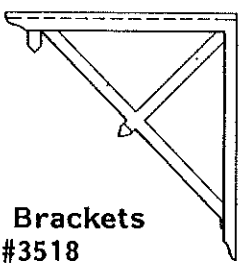

Roof Brackets
#3518

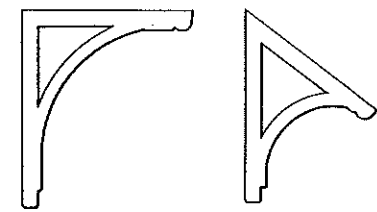

Eave and Gable Brackets
#3516

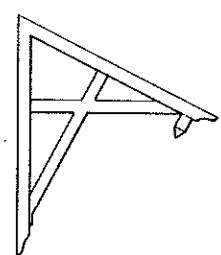

Side Roof Brackets
#3519

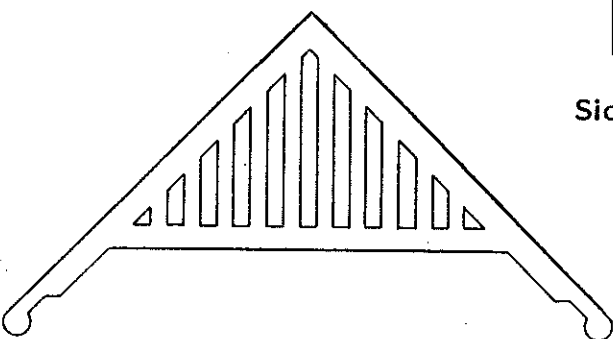

RGS Station Gable Trim
#3521

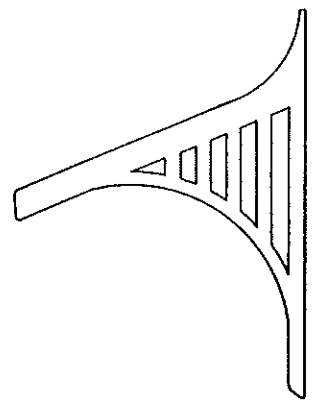

RGS Station Eave Trim
#3522

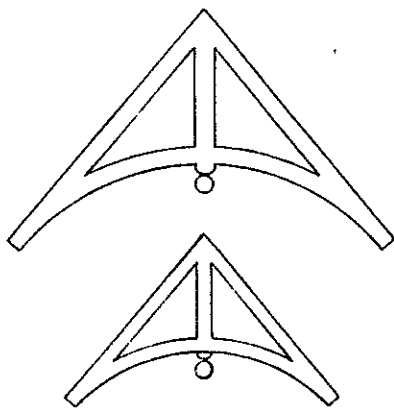

Roof and Eave Trim
#3539

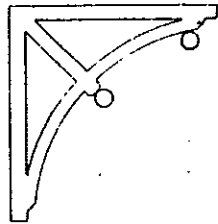

Ornate Gable Trim
w/ Brackets
#3545



RGS Station Roof Trim
#3523

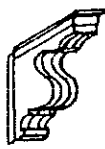

Victorian Bracket
#3530

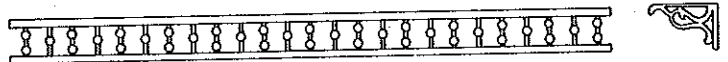

Upper Porch Spool Trim
with Brackets
#3526

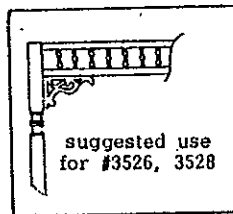

suggested use
for #3526, 3528



Wood Porch Railing
with Bracket
#3505

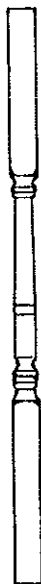

Turned Wood Porch Post
and Ball Newel Post
#3528



Square Newel
#3537
formerly Gould #1019



Bracket for
Porch Trim
#3546



Square Porch Post
#3536
formerly Gould #1009

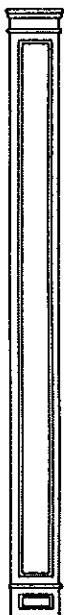

Pilaster
3'6" h x 12" w x 3 1/2" d
#3548

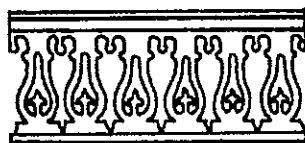

Sawed Ballustrade
#3535
formerly Gould #1020

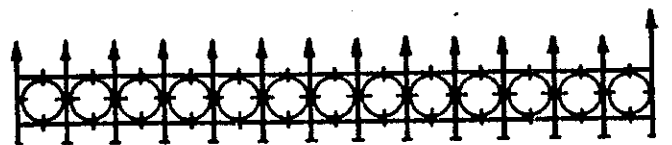

Widow's Walk Iron Railing
#3531
formerly Gould #1014

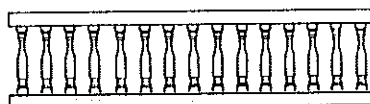

Victorian Ballustrade
Turned Spindle
#3527

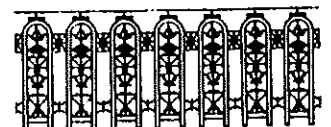

Balcony Railing
Wells Fargo
#3501

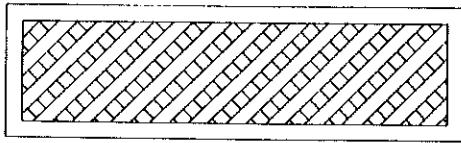

Band Stand Lattice
#3517

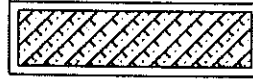

Band Stand Lattice
5064

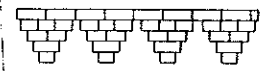

Brick Cornice
Wells Fargo
#3504

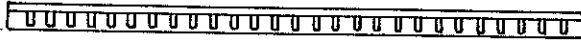

Dentils
3/pkg
#3550

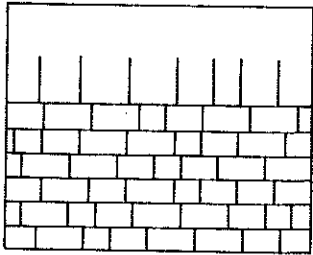

Shingles
textured paper card stock
#3529

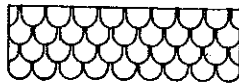

Scalloped Shingles
3" x 5" Sheet,
#3551

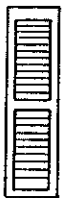
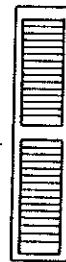

Louvred Shutters
13" x 48" #3540
14" x 64" #3541
15" x 87" #3542
17" x 64" #3543
18.5" x 64" #3544

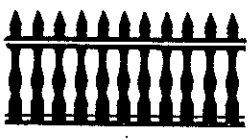

Picket Fence
#3514

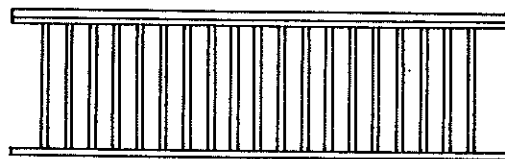

Porch and Lanai Railing
#3549

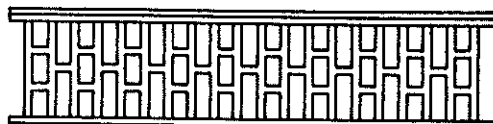

#3555
"Stick" Railing

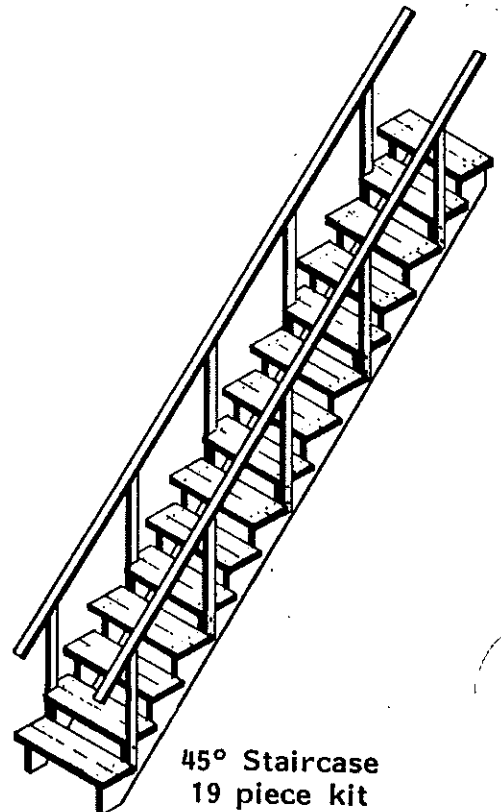

45° Staircase
19 piece kit
#3533
formerly
Could #1007

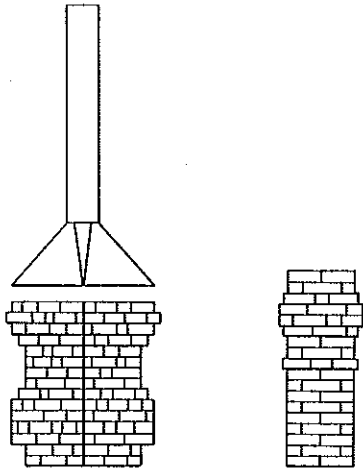

D&RGW Station Chimneys
#3509

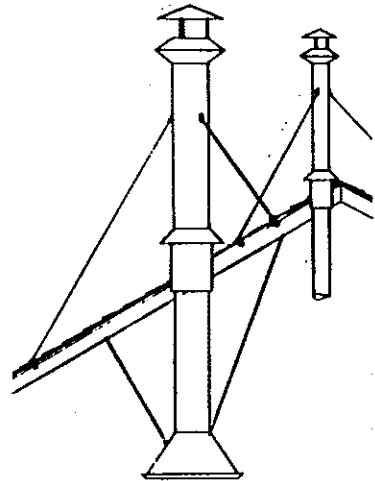

Engine House Stack Set
18" and 9"
#3512

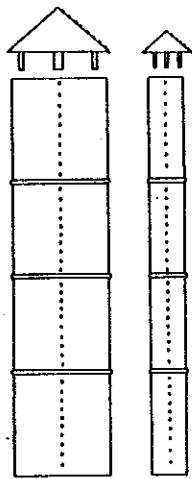

Smokestack Set
#3547

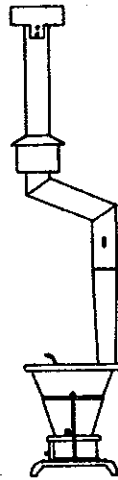

Stove
#3009

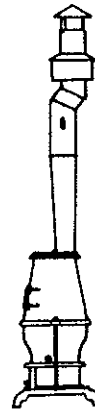

Stove
#3010

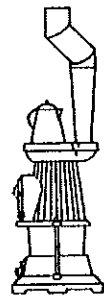

Stove
#3068



Stovepipe
#143



Stovepipe
#2114
(in brass only)

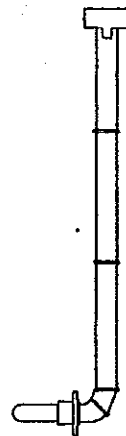

#4060
Smoke Jack

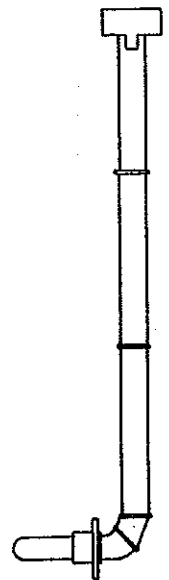

#3552
Smoke Jack

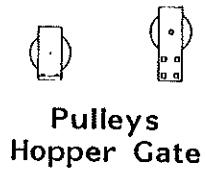

Pulleys
Hopper Gate

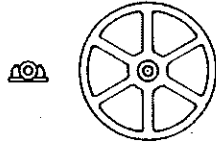
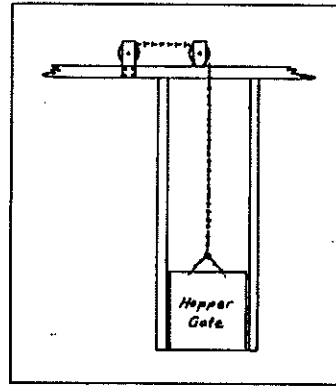

34" Sheave
Upper Hoist

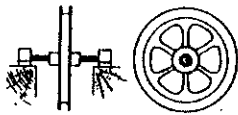

24" Sheave
Lower Hoist

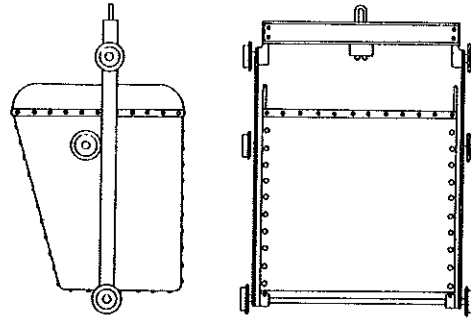

Bucket

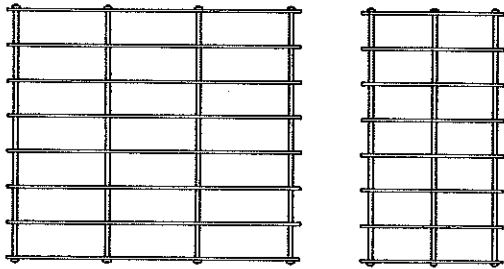

Grates

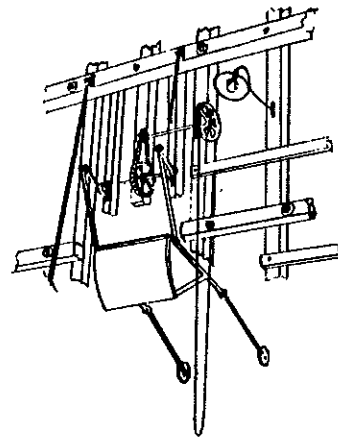

Coal Chute Gate
Operating Mechanism

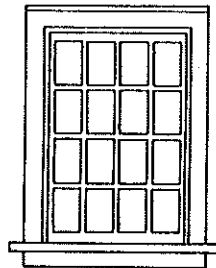
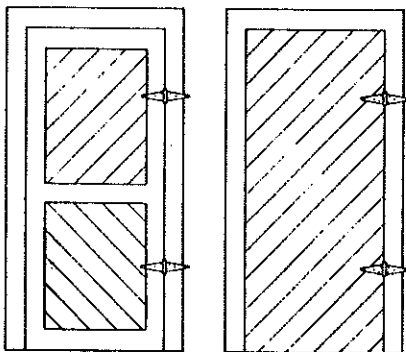

- 2 1/2" Nuts, Bolts, Washers
- 2 1/2" Nuts on Rectangular Washers
- 1 1/2" Nuts, Bolts Washers

Detailing Kit
Chama Coal Chute
#3046

CAR COMPONENTS

BOX CARS

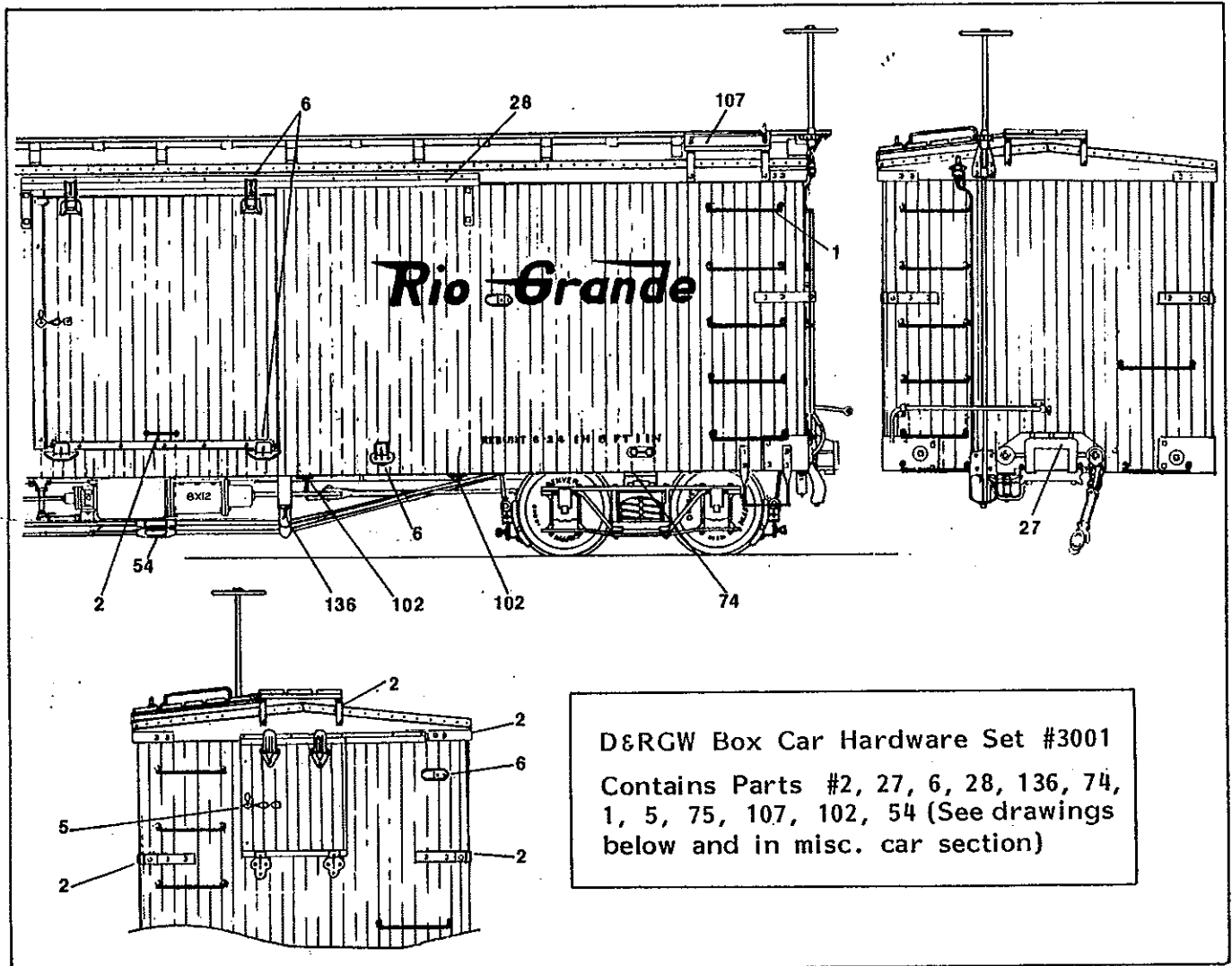

D&RGW Box Car Hardware Set #3001
 Contains Parts #2, 27, 6, 28, 136, 74,
 1, 5, 75, 107, 102, 54 (See drawings
 below and in misc. car section)

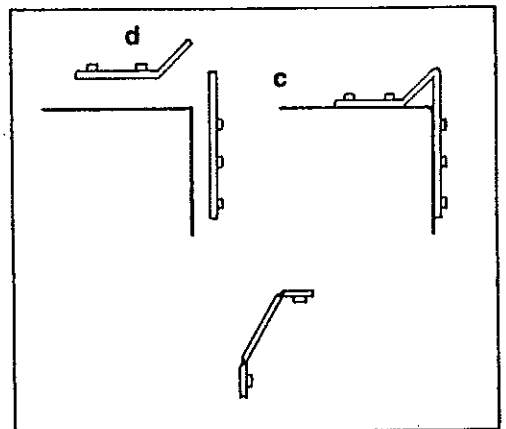
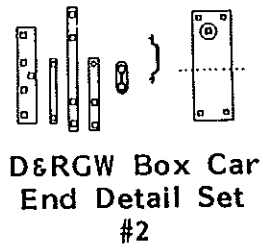
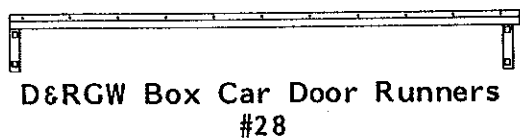
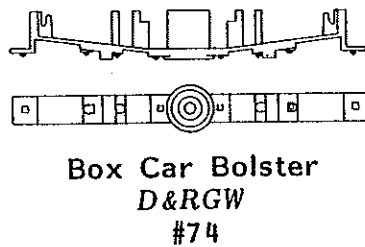
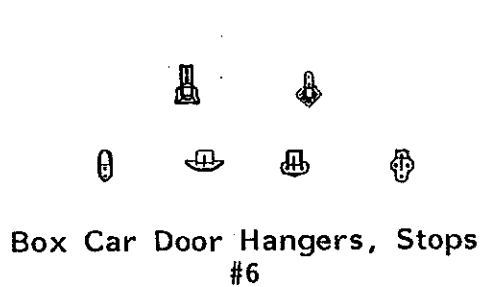



Box Car Door Latches
3 Open, 6 Closed
#5

Roofwalk Supports for
Narrow Gauge Cars



with Murphy Roofs
#144



without Murphy Roofs
#145

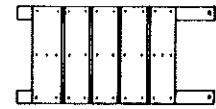

D&RGW Box Car
End Roof Walks
#107

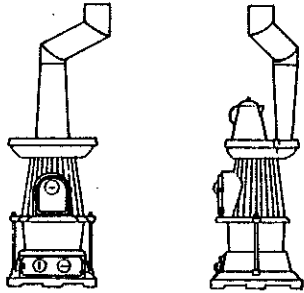

"Estate"
Caboose Stove
#3068

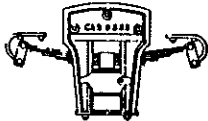

C&S Caboose Pedestals
w/ Journal Boxes, Springs
#141

D&RGW Caboose
Grab Iron Ends,
Marker Brackets
#60
in brass, #160



Caboose Smoke Jack
#143
in brass, #2118

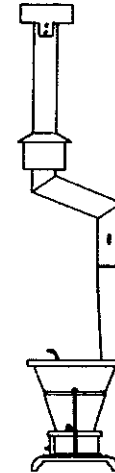

D&RGW Caboose
Stove with Stack
#3009

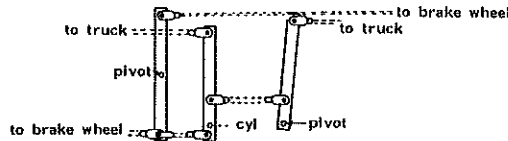

D&RGW Caboose
Brake Levers
#84

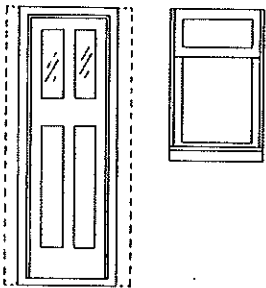

C&S Caboose
Window and Door Set
#52

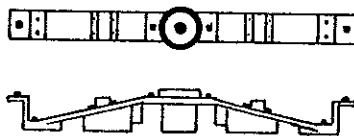

D&RGW Bolsters
for Short Caboose or Reefer
#64
in brass, #1064

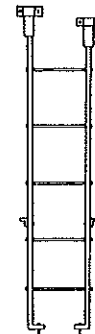

D&RGW Short Caboose
Ladders
#2105
in brass only

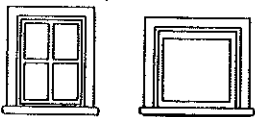

D&RGW Short Caboose
Cupola Windows
#49

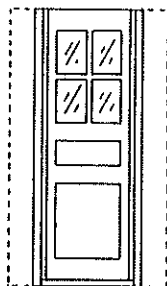

D&RGW Caboose
Doors
#50

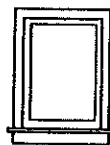

D&RGW Caboose
Side Windows
#21

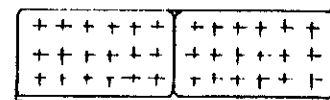

Caboose Bunk Cushions
#78

PARTS LIST FOR C&S #1006 CABOOSE

SOLD BY THE BAG AS IN THE KITS (ENOUGH FOR ONE LOCOMOTIVE) OR BY THE SPRUE(S)
 WIRE AND METAL PARTS ARE INCLUDED IN THE BAGS ONLY. THEY ARE NOT AVAILABLE SEPARATELY.

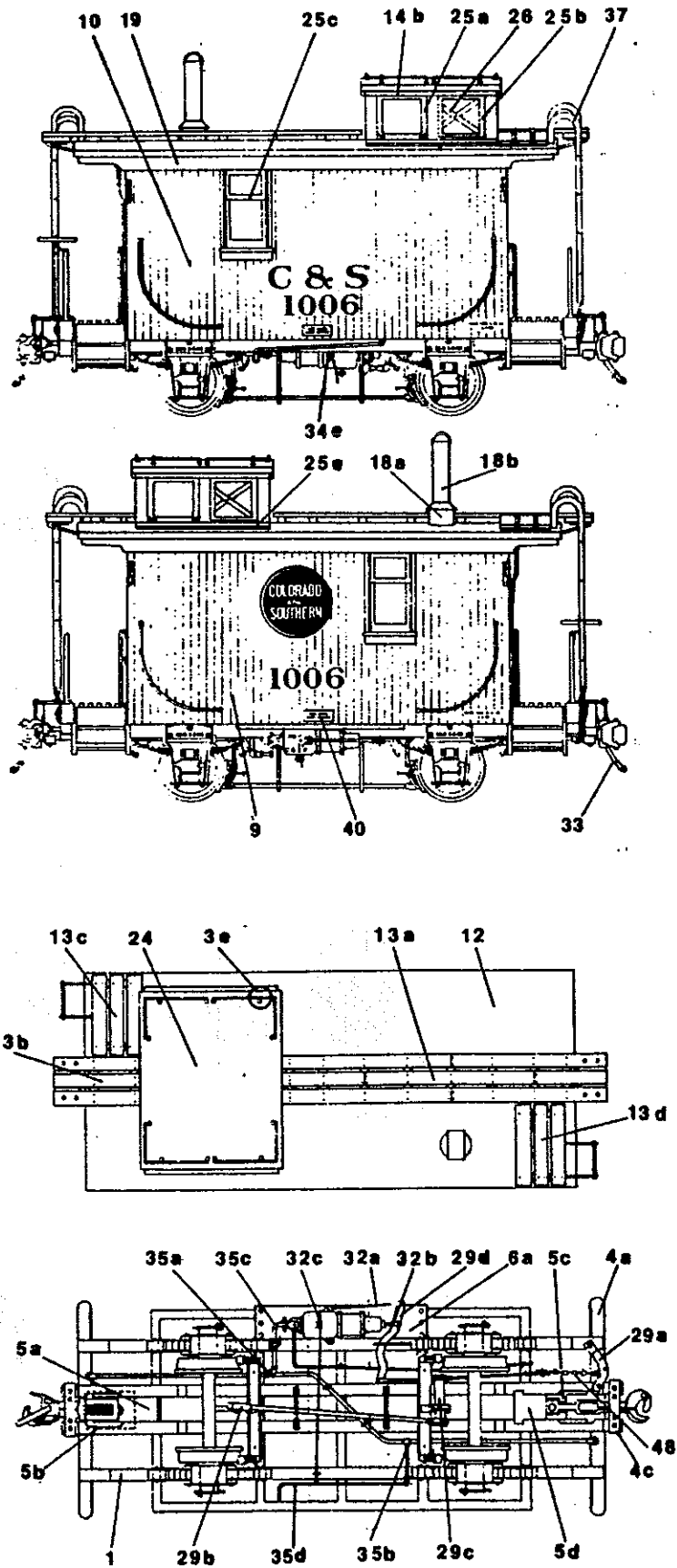

Part No.	Description	Qty
3071-50	Bag #1	1
3071-01	Frame	1
3071-09	Right Side	1
3071-10	Left Side	1
3071-11a	"A" End	1
b	"B" End	1
3071-12	Roof	1
3071-13a	Long Roof Walk	1
b	Short Roof Walk	1
c	Narrow CrossWalk	1
d	Wide Cross Walk	1
3071-17	Floor	1
3071-19	Side Fascia Boards	2
3071-51	Bag #2	
3071-14a	Main Roof Rib	4
b	Top Window Retainer	2
c	Cupola Rib	2
3071-15a	End Fascia	2
b	End Trim Boards	2
3071-16	Doors	2
3071-20	Step Sides	4
-21a	Center Step	4
b	Bottom Step	4
3071-22	End Platforms	2
3071-52	Bag #3-Cupola	1
3071-23a	Cupola End	2
b	Cupola Side	2
c	Cupola Locating Strip	2
3071-24	Cupola Roof	1
3071-25a	Cupola Outside Windows	2
b	Inside Cupola Windows	2
c	Side Window	2
d	Marker Bracket	4
e	Cupola Bottom Rail	2
3071-26	Cross Bracing	2
3071-53	Bag #4	1
3071-02a	Front Pedestal	4
b	Rear Pedestal	4
c	Keeper	4
-03a	Spring	4
b	Journal Box Front	4
c	Journal Box Rear	4
d	Journal Box Lid	4
e	Eyebolts	12
3071-04a	Endsill	2
b	Striker Plate	2
c	Frame Extension Carry Iron	4
d	Nut, Bolt, Washer	4
e	Nut, Bolt, Washer	2
3071-05a	Kadee Coupler Adapter Plate	2
b	Kadee Cover Plate	2
c	Grandt Line Cplr Cover Plate	2
d	Grandt Line Cplr Retaining Plate	2

Part No.	Description	Qty	Part No.	Description	Qty
3071-07	Wheels	2	3071-28	Brake Shoe	
3071-08	Couplers-Delrin	2		Hanger-Delrin	4
3071-54	Box #5	1	3071-29a	Lower Staff	
3071-18a	Thimble	1		Bracket	1
b	Jack	1	b	Dead Lever	1
3071-27	Brake Beam-Shoes Delrin	2	c	Live Lever	1
3071-31	Brake Wheel		d	Floating Lever	1
	Delrin	1	e	Upper Staff	
3071-34a	Coupler Lift Bar for "A" End	1		Bracket	1
b	Coupler Lift Bar for "B" End	1		All Delrin	
c	Coupler Lift Bar Brackets, Inside	2	3071-30	Brake Cylinder	1
d	Coupler Lift Bar Brackets, Outside	2	3071-32a	Floating Lever	
e	Eyebolt Plate	1		Tie Rod	1
	All Delrin		b	Piston Rod	1
3071-35a	1 1/4" Union Tee	1	c	Release Rod	1
b	3/4" Tee	1		All Delrin	
c	1 1/4" Pipe Valve Cluster	1	3071-33	Air Hoses	2
d	3/4" Pipe Cluster	1	3071-36a	Retainer Valve	1
3071-37	Ladder-Delrin	2	b	Ratchet/Pawl	1
3071-38a	Right Side End Railing-Delrin	2	3071-39	Handrail Bending Fixture	1
b	Left Side End Railing-Delrin	2			
3071-40	US Safety Appliance Plate	1	3071-56	Bag #7	1
3071-48	Hand Brake Chain-Polyethylene	1		Includes: Upper Heat Shield, Short Roof Rib, Roofwalk Support Material .008 Bronze Strip, Brake Push Rod, Brake Staff-Brass Rod, Push Rod Supports .020" Brass Rod, Release Valve Control Rod-.008 Bronze Wire	
3071-55	Bag #6	1	3071-41a	Upper Heat Shield w/Thimble	1
3071-06a	Brake Cylinder Mounting Plate	1	b	Short Roof Rib	1
b	Bending Fixture	1	3071-57	Card #8	1
c	Bending Wrench	1		Includes: Handrail Material-Retainer Pipe .016 Rod and Brake Line Material-.032 Rod	

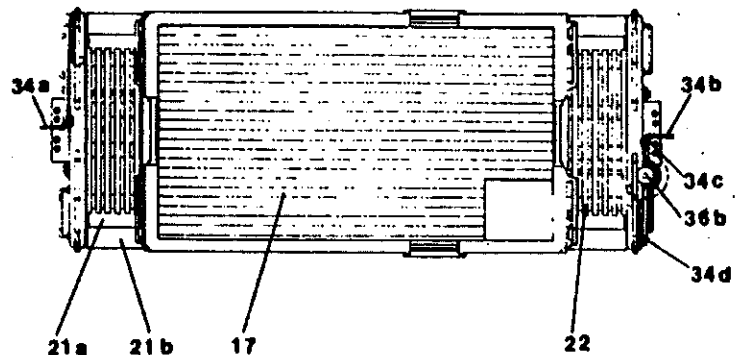
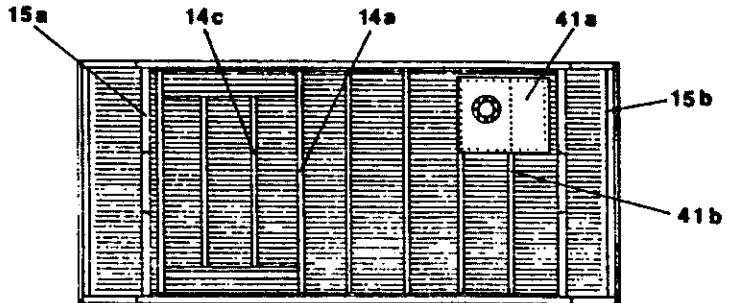
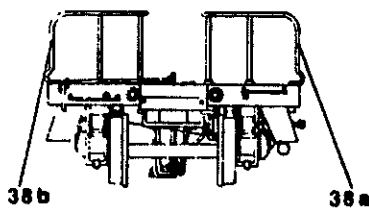
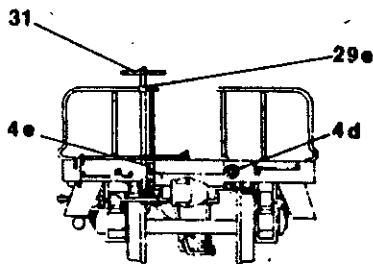
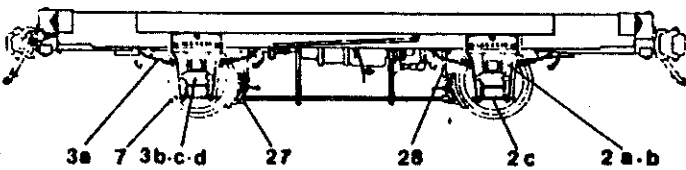
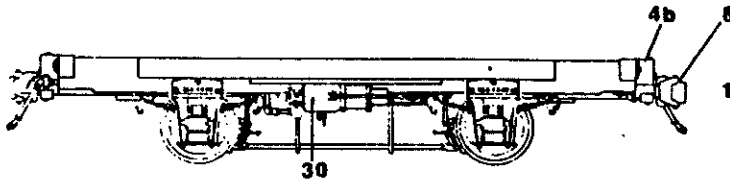
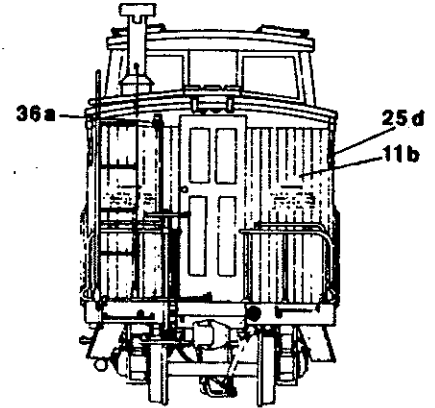
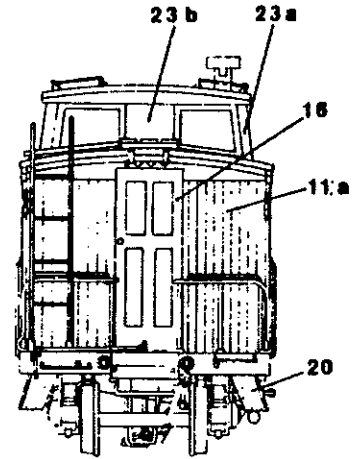

FLATS AND GONS

DENVER AND RIO GRANDE WESTERN

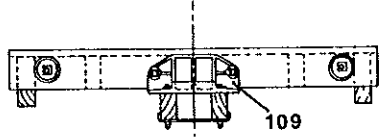
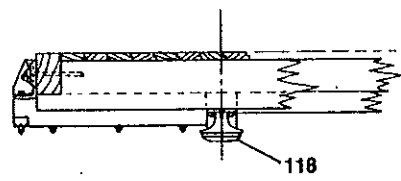
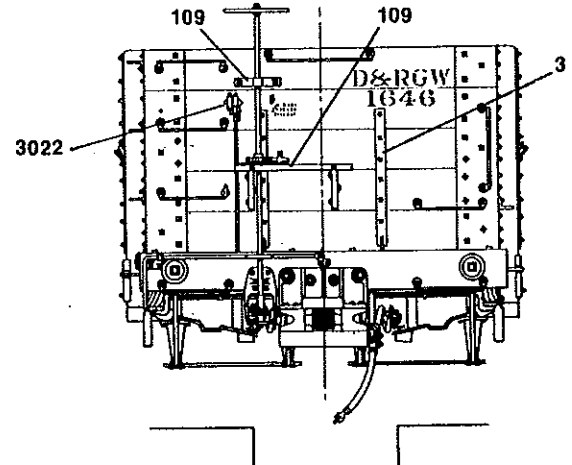
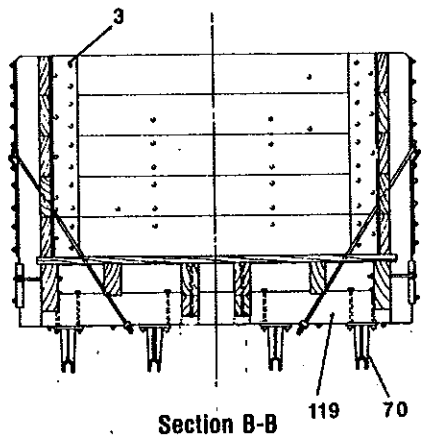
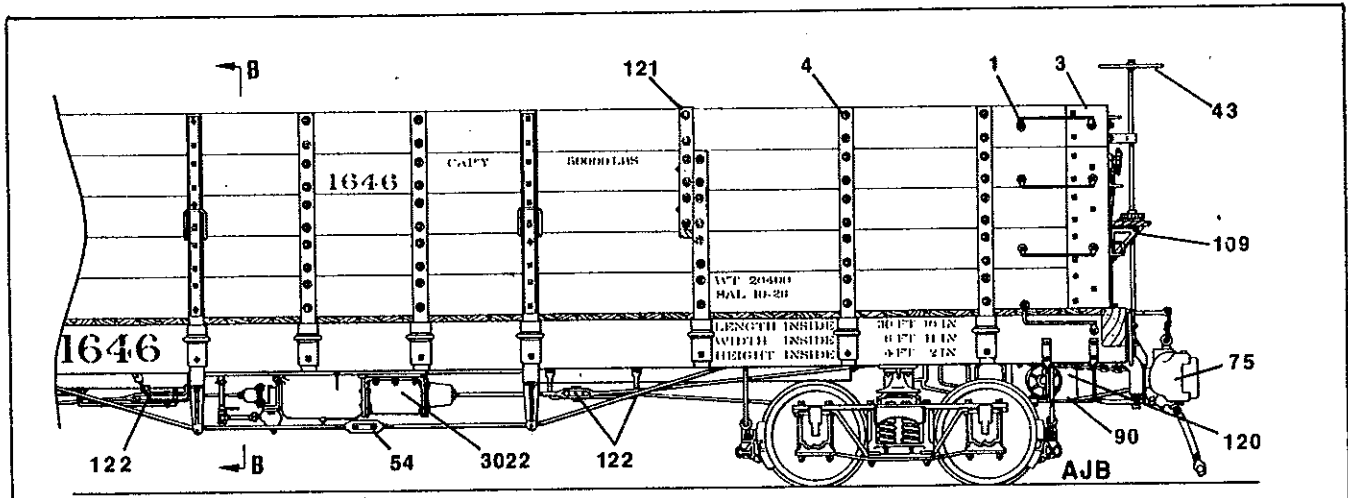

Drawn by Allen J. Brewster, copyright Kalmbach Publishing Co., 1978
 Reprinted with permission of Model Railroader Magazine.

D&RGW High Side Gondola Hardware Set #3002	Contains:
	#1, 3, 4, 43, 75, 109

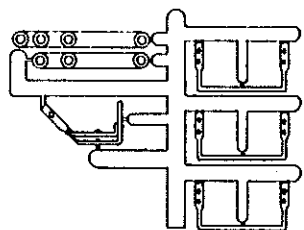

D&RGW High-side Gon
Levers, Fulcrum, Lever Guides
#122
in brass, #1122

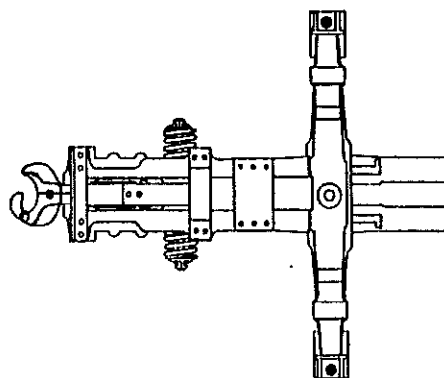

D&RGW High-side Gon
Economy Draft Gear, Bolster Set
#120

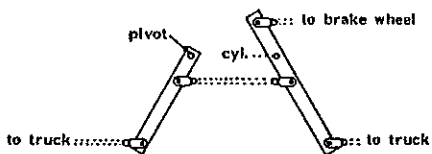

D&RGW Gon
Brake Levers, Clevises
#47



D&RGW High-side Gon
Needlebeam, Queenpost Sub-assembly
#119

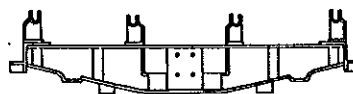

High-side Gon Bolster
Cast Steel Modified Standard Gauge
#118

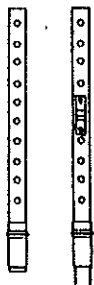

D&RGW High-side Gon
Stakes (4 long, 16 short)
#4



D&RGW High-side Gon
Side Stake Extension
#121

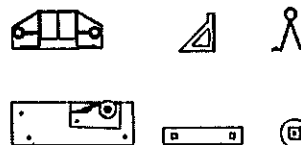

D&RGW High-side Gon
Coupler Pocket, End Detail
#109



D&RGW Drop Bottom Gon
Coupler Pocket
#66
in brass, #1066

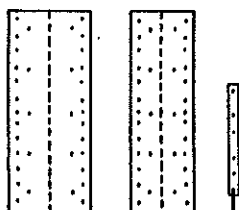

D&RGW High-side Gon
Corner Plates (inside, outside)
#3

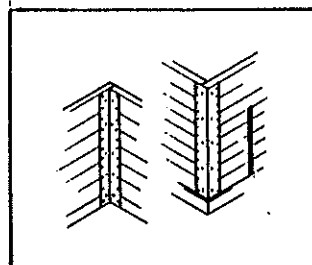

SOUTHERN PACIFIC



1 1/4 " nut, bolt, washer (#1)
2 1/2 " nut, bolt, washer (#16)

SP Low-wall Gon
Hardware Set
#3008

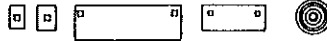

SPNG Car Details
#61



SP Low-wall Gon Stakes
#7

PASSENGER CARS

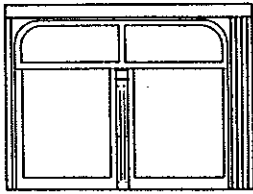

Hall Scott Double Windows
Nevada Copper Belt
#3807

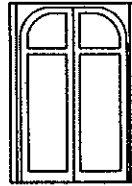

Hall Scott Motormans Windows
Nevada Copper Belt
#3808



Hall Scott Oval Windows
Nevada Copper Belt
#3809

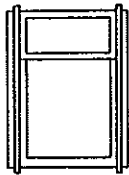

Wide Coach Windows
D&RGW
#3801

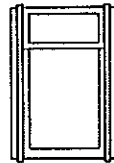

Narrow Coach Windows
D&RGW
#3803

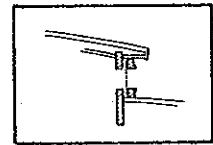

Clerestory Windows
with Screen
D&RGW
#3806

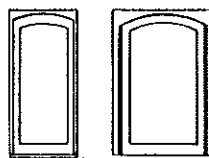

SR&RL Combine
Side and End Windows
#3812

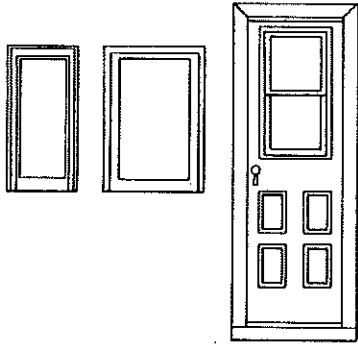

2' Coach Windows, Doors Set
SR&RL #20
#3811

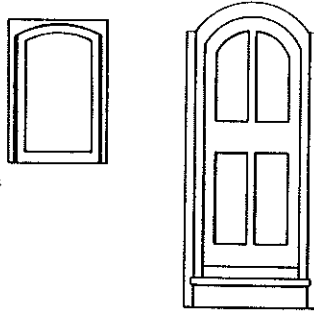

SR&RL/RPO
Narrow Doors, Side Windows
#3816

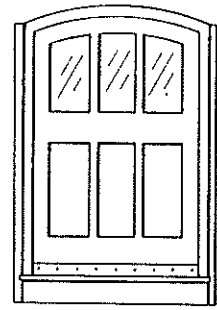

SR&RL Combination
Side Doors
#3814

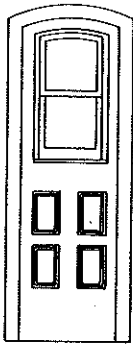

SR&RL Combine/Baggage
End Door
#3813

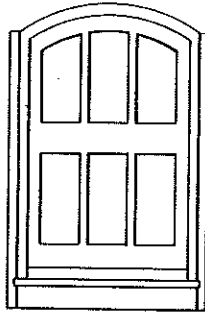

SR&RL/RPO Wide Door
#3815

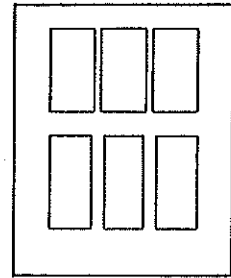

Combine Baggage Doors
D&RGW
#3805

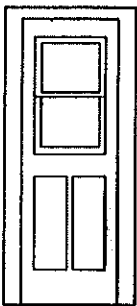

Coach End Doors
D&RGW
#3802

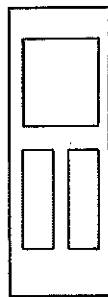

Vestibule Doors
D&RGW
#3804

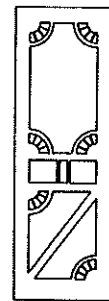

Screen Door
D&RGW Business Car B-7
#3810



Passenger Car Corner Moldings
#3817



Passenger Car Stove
D&RGW
#3010



Passenger Car Smoke Jack
in brass only, #2114

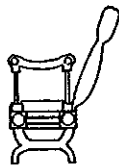

Narrow Gauge Coach Seats
Wood End
#3016
with 2 Ends
for Old Time Standard Gauge Cars
and Inter-urbans
#3017

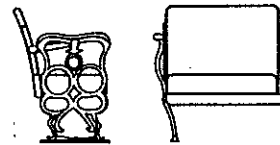

Narrow Gauge Passenger Car Seats
D&RGW
#3003

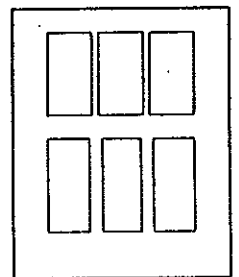
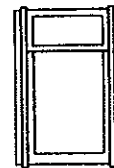
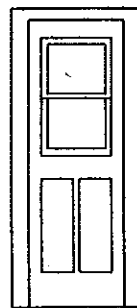

D&RGW Combine Set
#3004



actual size

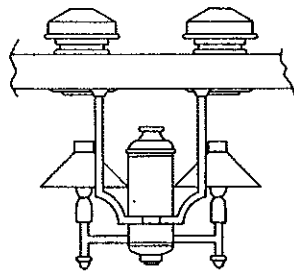

drawn 2x actual size

D&RGW Coach Oil Lamps
#3011

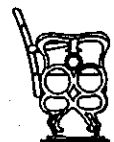
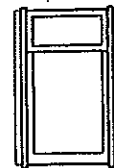
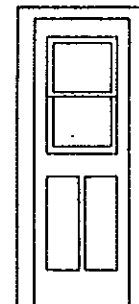

D&RGW Coach Set
#3005

26

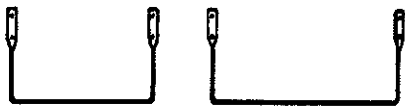

RPO Baggage Car
Stirrup Steps
36" and 48"
#3820



21" Passenger Car Steps
#3818

27" Passenger Car Steps
#3819

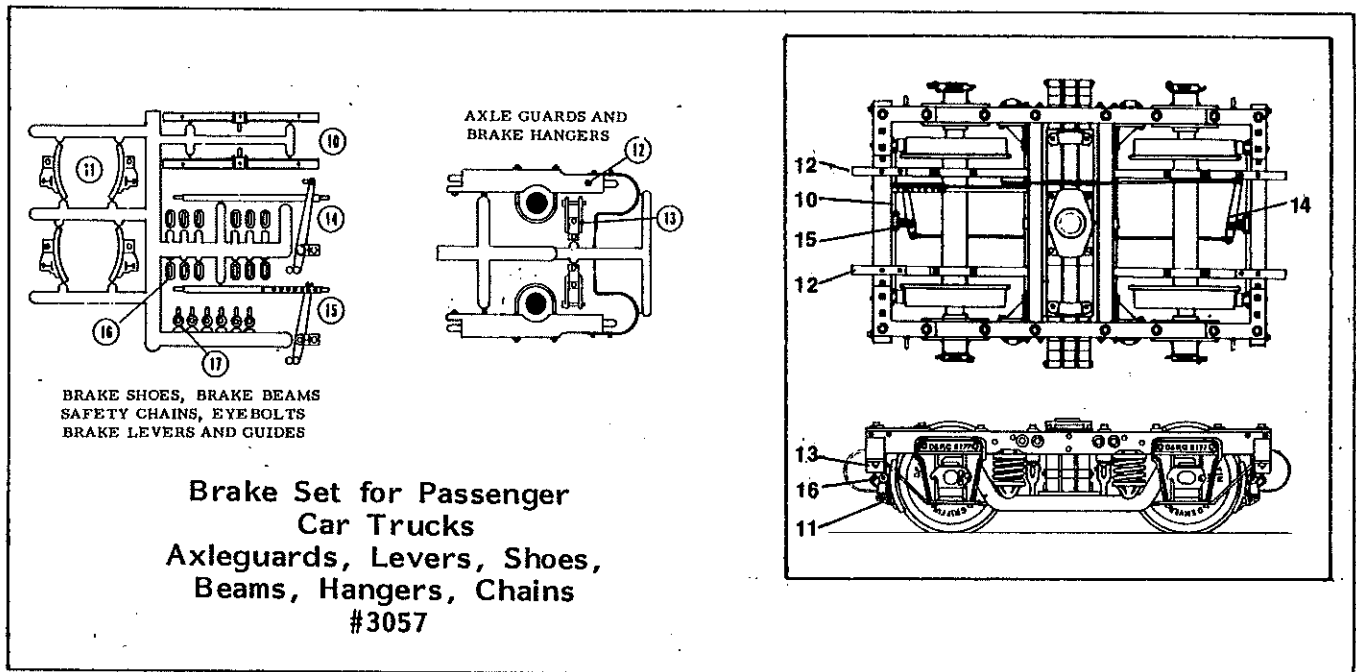

REFRIGERATOR CARS

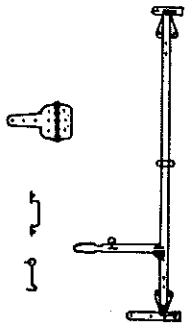

D&RGW Refrigerator Car
Door Hardware Set
#10

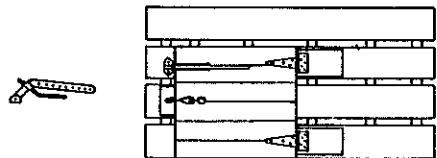

D&RGW 30' Refrigerator Car
Ice Hatches, Platforms
#14

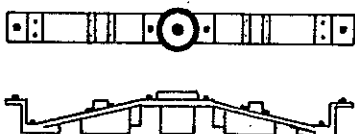

D&RGW Bolsters
for Short Caboose or Reefer
#64
in brass, #1064



D&RGW 30' Refrigerator Car
Coupler Pocket
#59
in brass, #1059

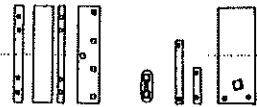

D&RGW 30' Refrigerator Car
End Detail
#71

D&RGW 30' Refrigerator Car
 Hardware Set
 #3006
 Contains Parts #14, 10,
 71, 1, 59, 75, 64, 69, 54

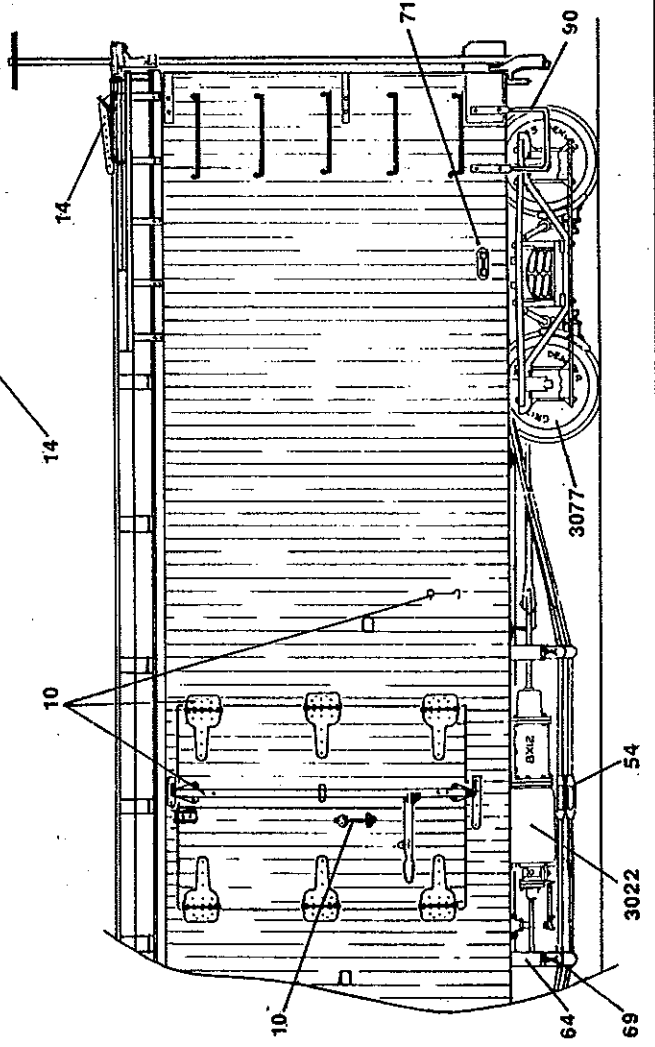
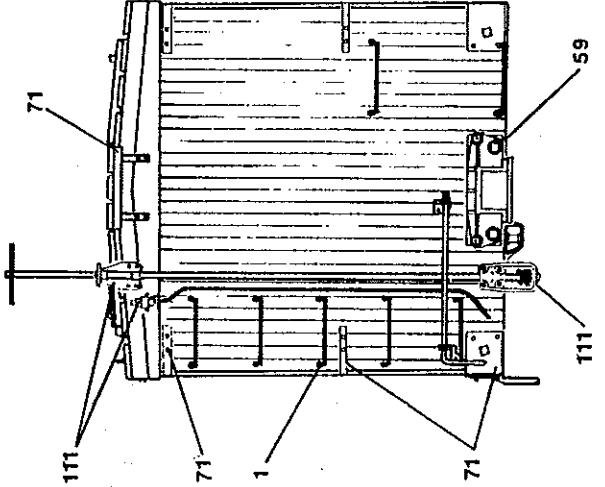
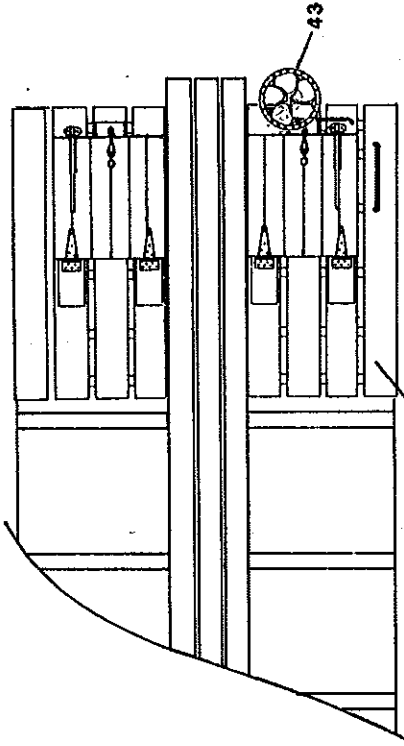

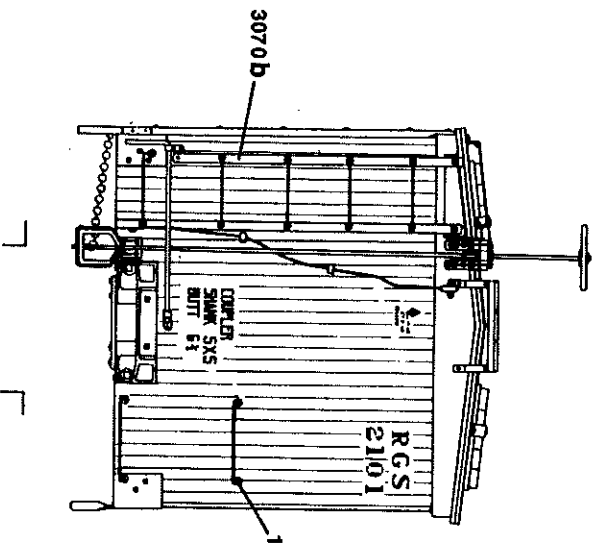
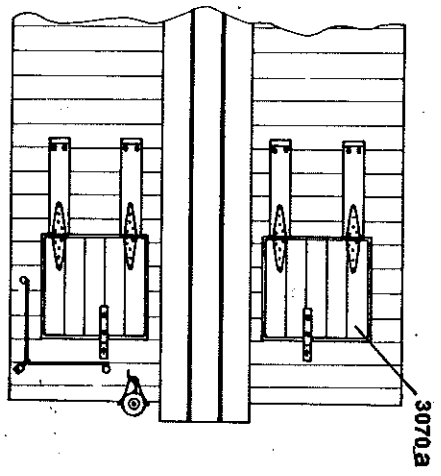
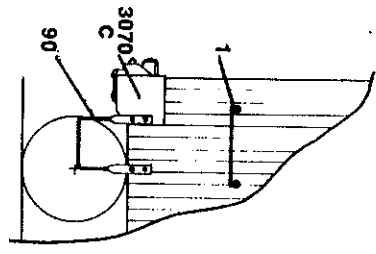
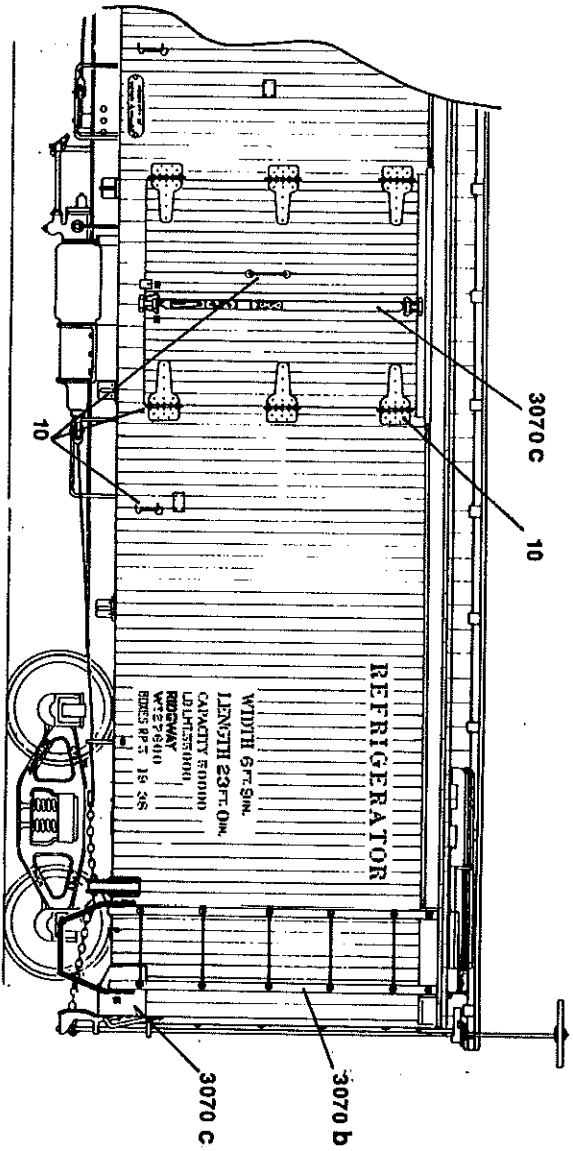

C&S/RCS Refrigerator Car
 Hardware Set
 #3070
 Contains Parts #1, 10, 90,
 3070-a, 3070-b, 3070-c,
 complete Bettendorf Underframe #3058,
 and Plans

STOCK CARS

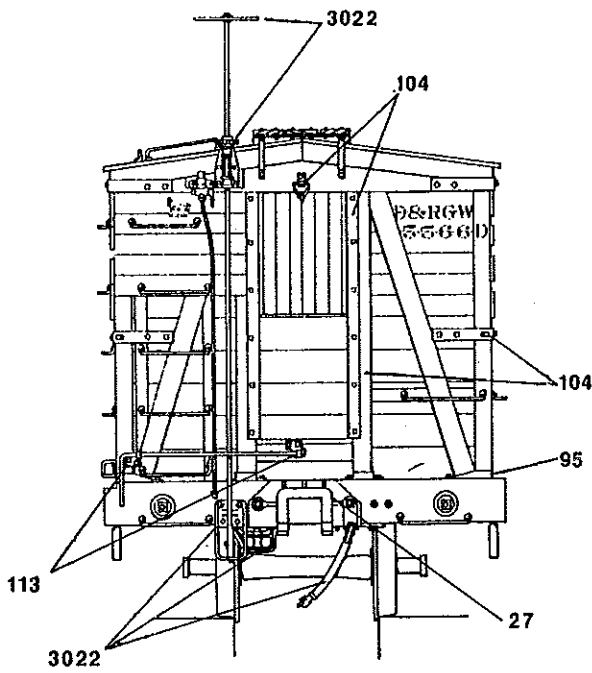

D&RGW Stock Car Hardware Set
 #3007
 Contains Parts #13, 1, 16, 27
 28, 95, 102, 103, 104

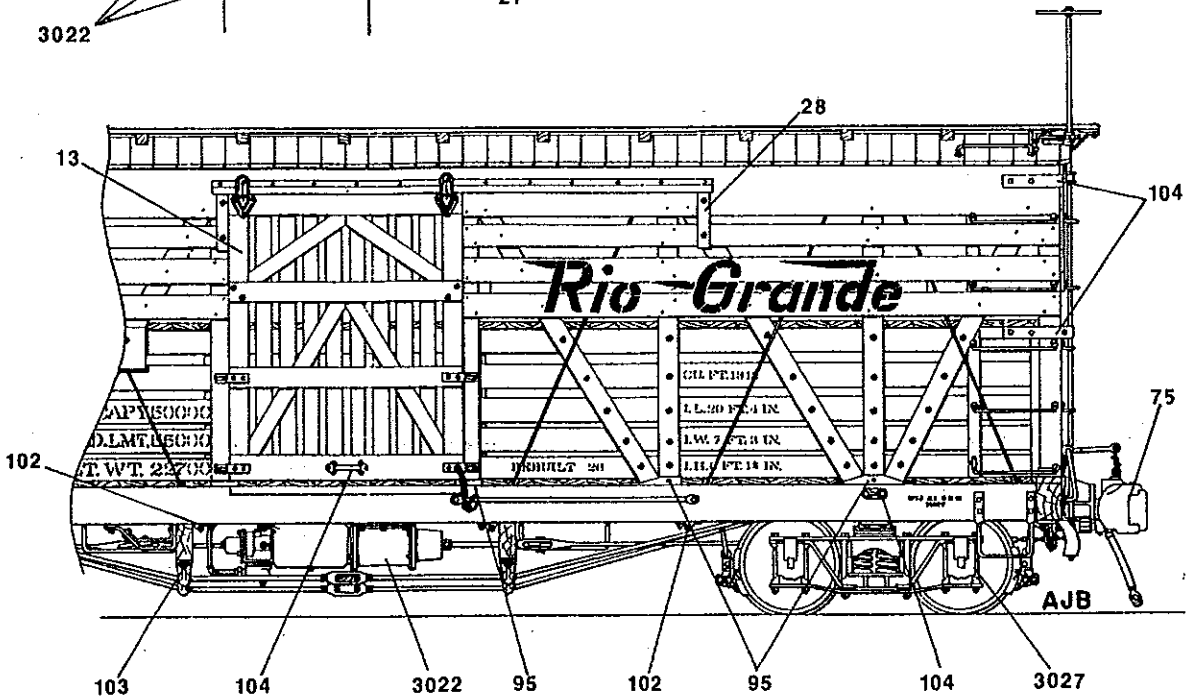

Drawn by Allen J. Brewster, copyright Kalmbach Publishing Co., 1972
 Reprinted with permission of Model Railroader Magazine.

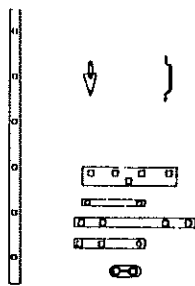

D&RGW Stock Car
End Detail
#104

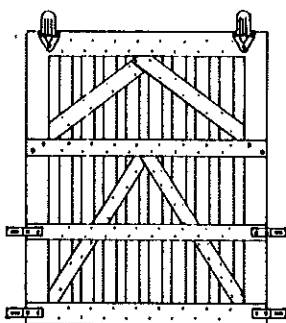

D&RGW Stock Car Doors
#13



D&RGW Stock Car
Post, Brace Feet
#95

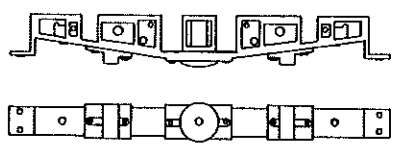

D&RGW Stock Car Bolster
for 30' Car
#103
in brass, #1103

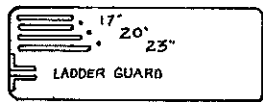

Grab-iron Bending Fixture
#148

MISCELLANEOUS FREIGHT CAR HARDWARE



drawn 2x actual size

Lift Ring, Eyebolt Assortment
#108
in brass, #1108

1P 199

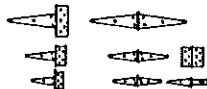

Hinge Assortment
11 Pair, 2 Hasps
#3508
in brass, #2125



D&RGW Scale Turnbuckles
Cored for .025" Wire
#54
in brass, #1054



3" Queenpost
Use for D&RGW Box, Stock Cars,
and Some Cabooses
#136
in brass, #1136



3" Queenpost
#69
in brass, #1069



5" Queenpost
#68
in brass, #1068



6" Queenpost
#67
in brass, #1067



10" Queenpost
#70
in brass, #1070



Post and Brace Tie Rod Plates
Box, Stock and Flat Cars
#102

NUTS, BOLTS, WASHERS

Shown 5X Actual Size

	#100	7/8" NUT, 1 3/8" STEEL WASHER, 1/2" BOLT; IN BRASS, #1100		#62	7/8" SQUARE NUT, BOLT, WASHER IN BRASS, #1062
	#101	1 1/16" NUT, 5/8" BOLT, 1 3/4" STEEL WASHER; IN BRASS, #1101		#23	1 1/2" NUT, BOLT, CAST IRON WASHER; IN BRASS, #1023
	#98	1 1/4" NUT, 2" STEEL WASHER, 3/4" BOLT; IN BRASS, #1098		#139	1 1/2" NUT, 4" CAST IRON WASHER CORED FOR .020" WIRE IN BRASS, #1139
	#99	1 5/8" NUT, 2 1/2" STEEL WASHER, 1" BOLT; IN BRASS, #1099		#16	2 1/2" NUT, BOLT, WASHER IN BRASS, #1016
	#63	1/2" SQUARE NUT, BOLT, WASHER IN BRASS, #1063		#80	2 1/2" SQUARE NUT, 6" SQ WASHER IN BRASS, #1080
	#1	1 1/4" NUT, BOLT, WASHER IN BRASS, #1001		#81	2 1/2" HEX NUT, 6" WASHER IN BRASS, #1081
	#8	1 1/4" NUT/BOLT AND NUT/BOLT/WASHER IN BRASS, 1008		#18	2 1/2" NUT, RECTANGULAR WASHER IN BRASS, #1018
	#9	1" SQUARE NUT, BOLT IN BRASS, #1009		#20	2 1/2" NUT, ELIPTICAL WASHER IN BRASS, #1020
	#82	2 1/2" SQUARE NUT, NO WASHER IN BRASS, #1082		#93	1 1/4" NUT, 3" MALLEABLE IRON WASHER; IN BRASS, #1093
	#15	1 1/4" HEX NUT, BOLT IN BRASS, #1015		#44	2 1/8" SQUARE NUT, 5" RIBBED WASHER
	#127	1 1/2" HEX NUT, BOLT IN BRASS, #1127			

RIVETS

.032" dia. Conical Head	#152	in brass, #1152
.032" dia. Round Head	#153	in brass, #1153
.043" dia. Round Head	#154	in brass, #1154
.043" dia. Conical Head	#155	in brass, #1155
.063" dia. Round Head	#156	in brass, #1156
.063" dia. Conical Head	#157	in brass, #1157



6 Spoke Brake Wheel
C&S SP
#88
in brass, #1088



D&RGW 16" Brake Wheel
Ratchet/Pawl
#43
in brass, #1043



Lovsted 15" Brake Wheel
Westside Lumber Co.
#94
in brass, #1094



D&RGW Old Time Brake Wheel
4 Spoke
#51
in brass, #1051

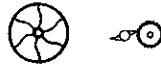

14" Brake Wheel
6 Spoke, Ratchet/Pawl
#33
in brass, #1033



Ajax
Brake Wheel
#160



Air Hoses, Angle Cocks
in Delrin
#115
in brass, #1115

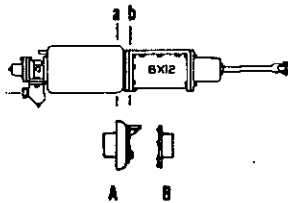

Westinghouse Brake Cylinder
Type K, 8" x 12"
#97
in brass, #1097

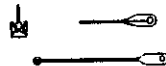

Brake Cylinder Release Valve
and Push Rod
in Delrin
#137



Clevises, Chain, Brake Levers
#114
in brass, #1114

To make separate cylinder and reservoir, cut the main casting at "a" and "b". Trim square and add pieces "A" and "B". Fit rod and clevis to suit.

- a-b Air Hose, Glad Hand
- c Reducing Elbow--1 1/4" to 1" with Pipe
- d Elbow with 1" Pipe
- e Elbow with 1 1/4" Pipe
- f Tee with 1 1/4" Pipe
- g,h,i 1 1/4" Couplings
- j,k 1 1/4" Unions
- l 1 1/4" Cut-out Cock
- m 1 1/4" Air Strainer with 1 1/4" Pipe

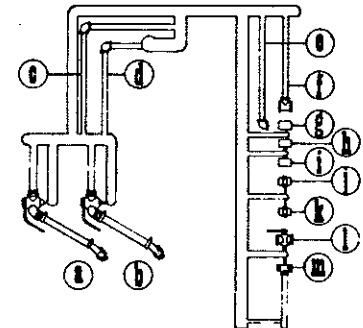

Miscellaneous Pipe Fittings, Air Hoses
#112
in brass, #1112



Centrifugal Dirt Collector
Duplex Retainer Valve
#146

View showing Centrifugal Dirt Collector with Westinghouse Brake Cylinder

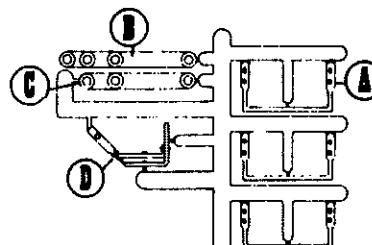

- a Lever Guides
- b Cylinder Lever
- c Live Lever
- d Live Lever Fulcrum

Levers, Fulcrum, Lever Guides
High Side Gon
#122
in brass, #1122

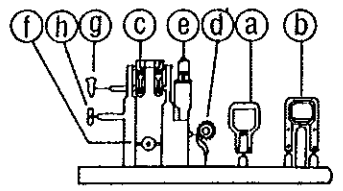

- a Lower Staff Bracket--Type A
- b Lower Staff Bracket--Type B
- c Upper Staff Bracket
- d Ratchet and Pawl
- e Side Chain Guide
- f Side Chain Roller
- g Retainer Valve Body
- h Retainer Valve Mounting Lugs

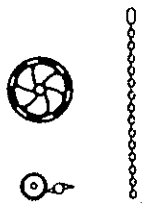

- a Brake Cylinder Mounting Block
- b Lower Staff Bracket
- c Reducing Valve
- d Brake Lever Bracket
- e Chain Guide and Roller
- f Reservoir Mounting Block
- g Upper Staff Bracket with Ratchet and Pawl
- h Plate with Ratchet and Pawl, for HS Con, Flats

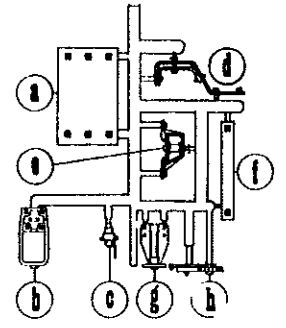

C&S/RGS Hand Brake Fittings
Brake Wheel, Side Chain Roller, Chain
 #129

D&RCW Brake Staff Brackets
w/ Miscellaneous Fittings
 #111
 in brass, #1111

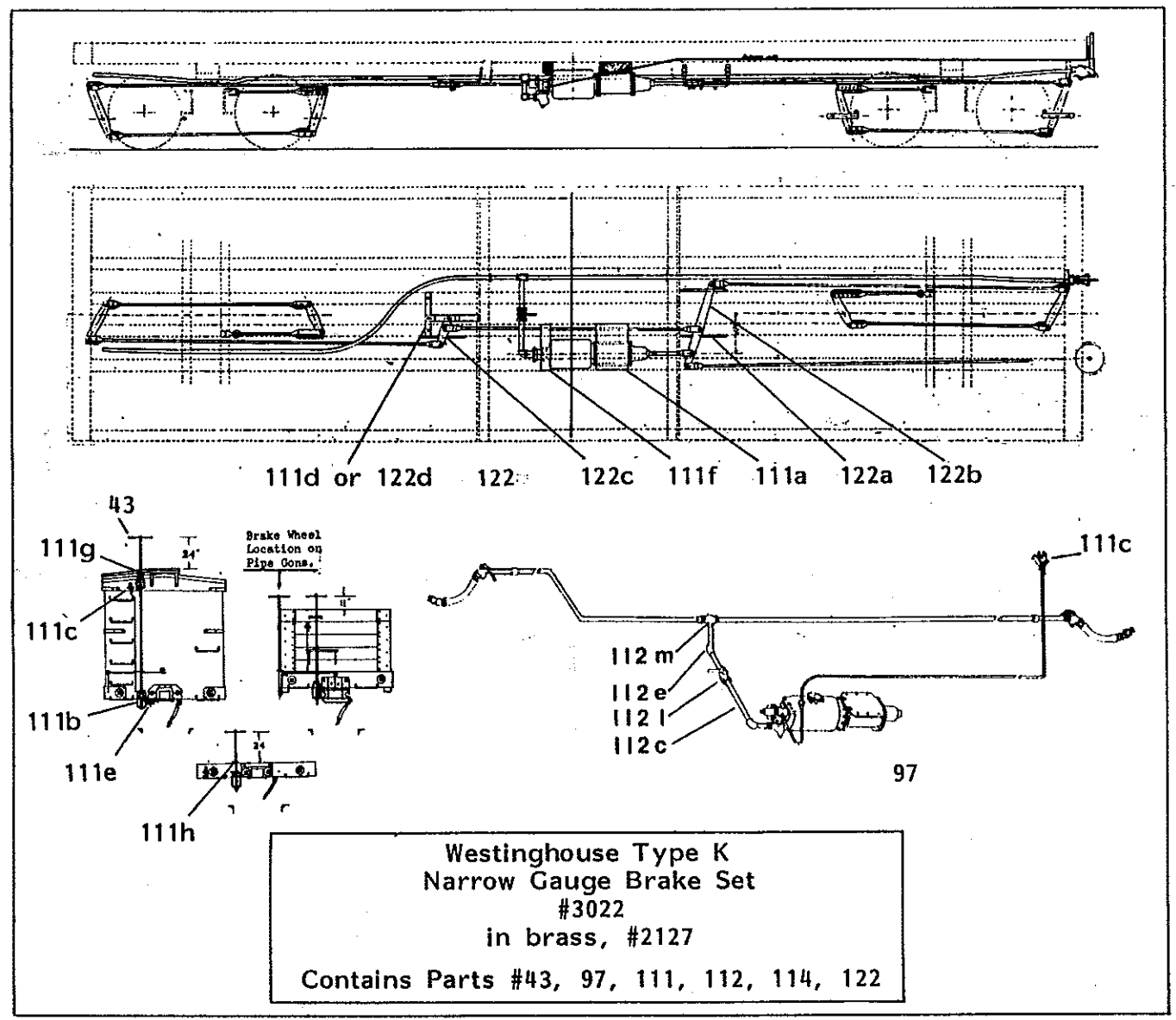

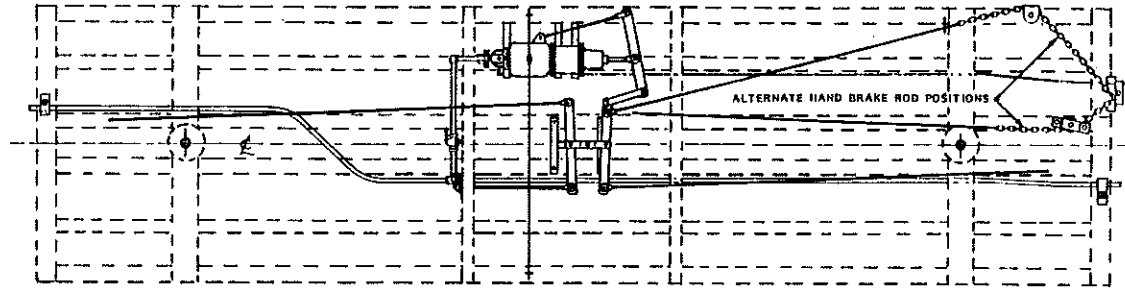

NY Air Brake Set, Type K, 8" x 8"
#138

Set Includes: Misc. Pipe Fittings, Air Hoses (#112); Clevises (#114); Brake Chain; C&S Brake Staff Brackets, Fittings; Brake Wheel (#88); Retainer Valve; Cylinder Release Valve, Push Rod (#137); Brake Levers; NY Brake Cylinder, Mounting Brackets

On the C&S, this brake system was used on the truss rod cars with archbar trucks, built for and by the C&S. (ie. Gons, Box Cars, Stock Cars, Cabooses).
A similar system was used on most F&CC Box Cars. These cars were subsequently sold to other railroads. In many cases, the brake system was maintained (ie. SP NG, Montana Southern, Pacific Coast RR, Magma, and N-C-O).



enlarged to show detail



D&RGW Brake Shoes, Beams
#29



Dummy "Tower" Couplers
#22

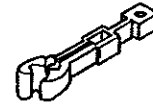

Tower Semi-Automatic Couplers
#75



D&RGW Box Car Coupler Pocket
#27
in brass, #1027

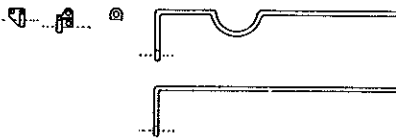

Coupler Lift Bars, Brackets
#113
in brass, #1113



Stake Pockets
Single U-Bolt
#89
in brass, #1089



D&RGW Stake Pockets
2 U-Bolts
#53
in brass, #1053



Stake Pockets
Single U-Bolt
#73
in brass, #2116



60" Stakes in Pockets
#17

Handwritten notes and scribbles on the right margin.

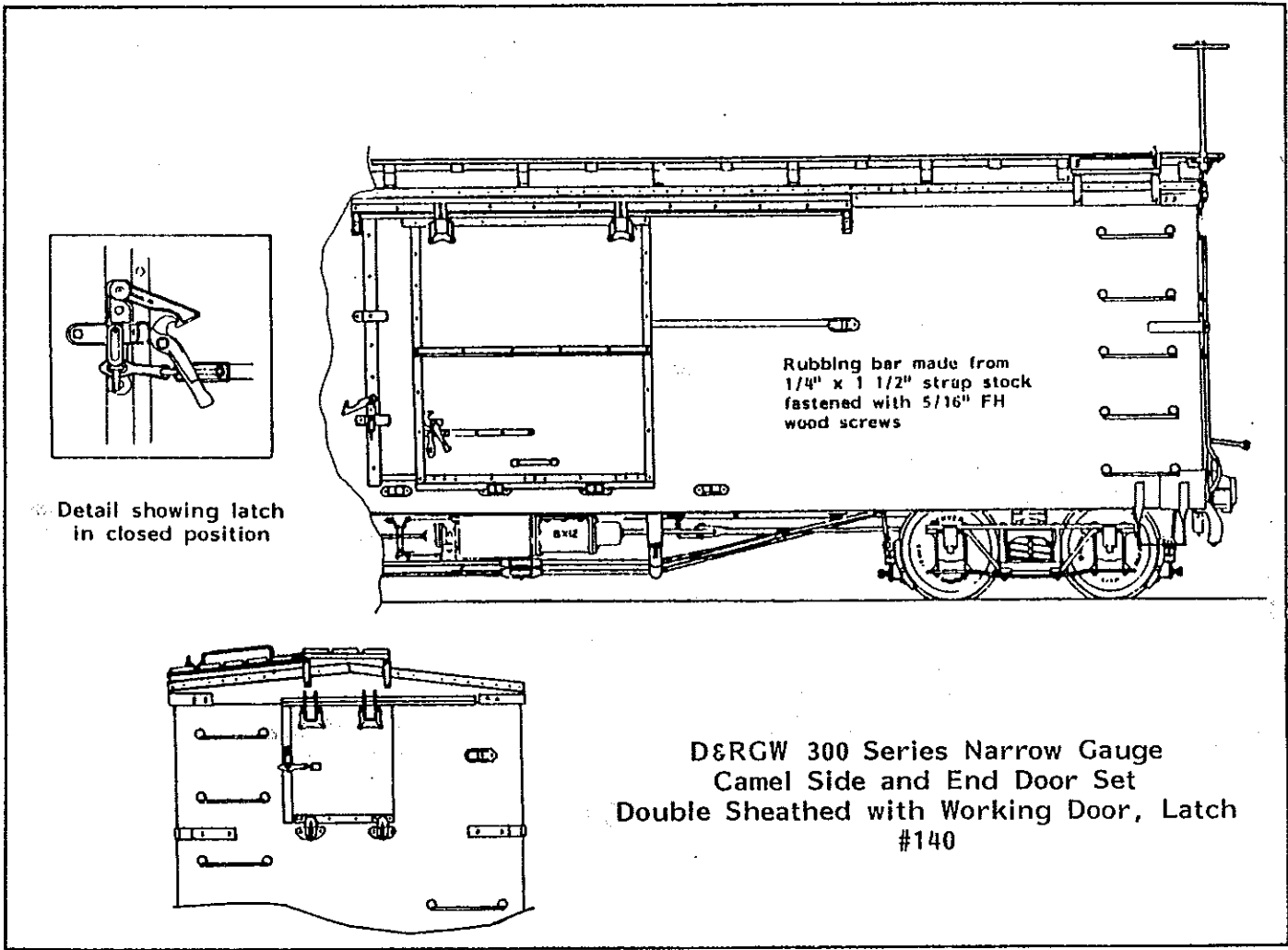

Handwritten notes on the left margin, including a large '8' and some illegible scribbles.

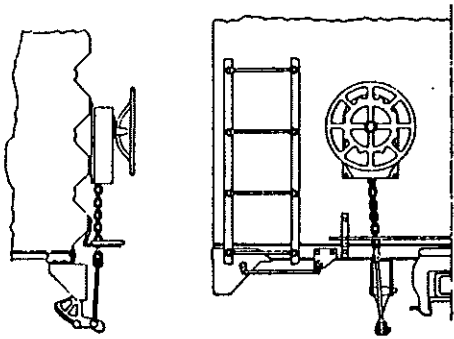

Typical Application c. 1980

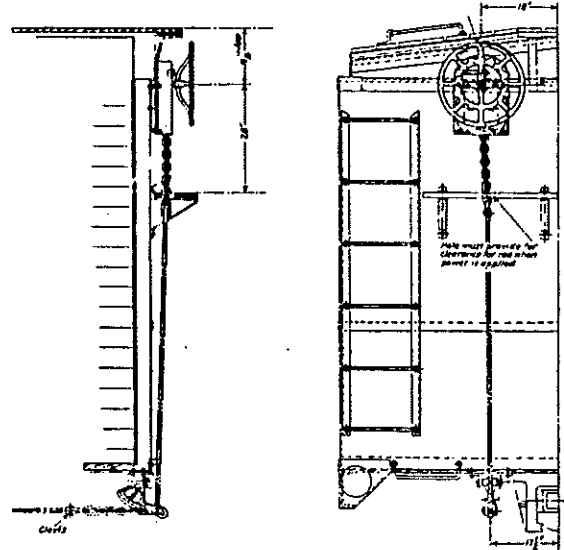

Typical Application c. 1935

View of AB Valve
Pipe Bracket

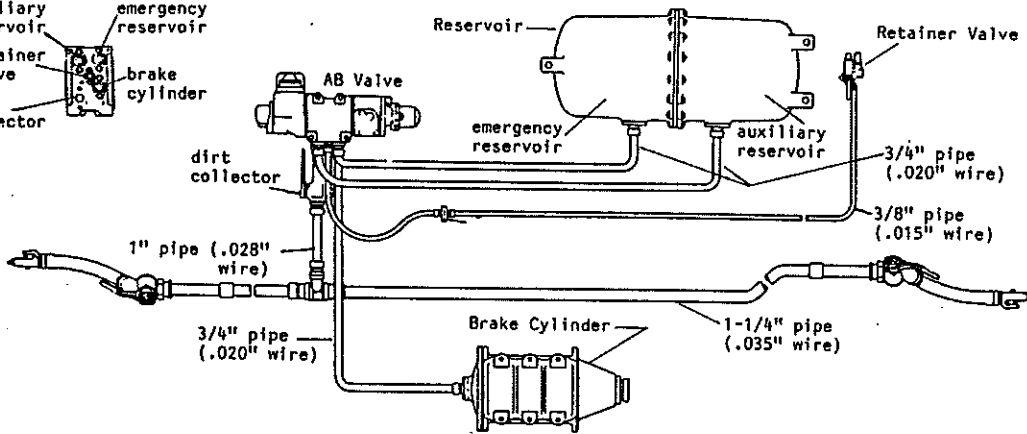
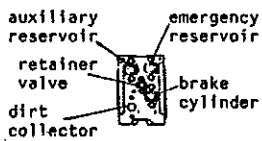

Piping Diagram

Westinghouse AB Brake Set

#3049

Set Includes: Brake wheel, AB Valve, Brake cylinder, Reservoir, Bell crank Ajax brake gear housing, Cylinder mounting bracket, Reservoir mounting bracket, Brake lever, Retainer valve, Dirt collector, Long and short brake rods, Chain

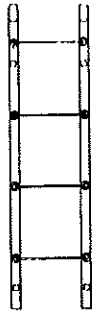

B&SR 4-Rung Ladder
Delrin
#65
in brass, #2136



Freight Car Stirrup Steps
Black Delrin
#83
Brown Delrin
#90
in brass, #1090

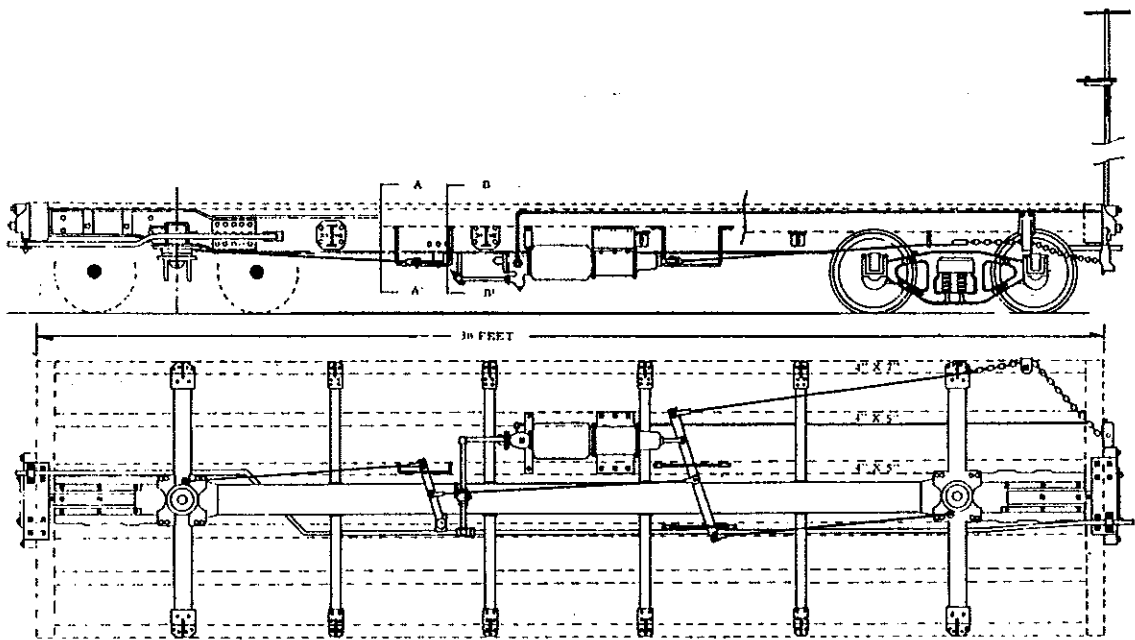

Bettendorf Steel Underframe Kit
#3058

Contains hardware parts to construct a complete Bettendorf Underframe, including brakes, trucks, and couplers for a C&S Steel Underframe House Car. Some modification is required to construct a gondola.

OTHER CARS

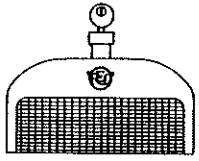

enlarged to show detail

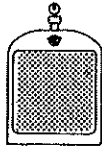

Reo Radiator
for Rail Cars, etc.
#106
in brass, #1106



SR&RL Railcar
Pedestals, Springs
#41

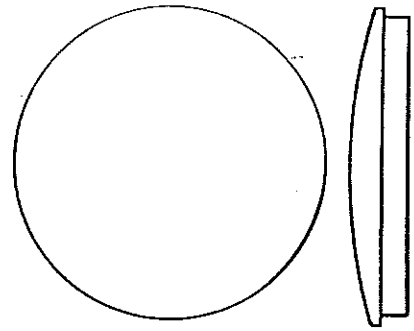

D&RGW Tank Car Ends
77" Diameter
#12

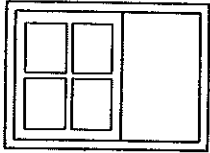

Outfit Car Window
Sliding, 4-pane
#26

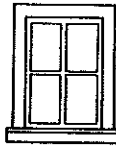

Outfit Car Window
Inside Hung, 4-pane
#25

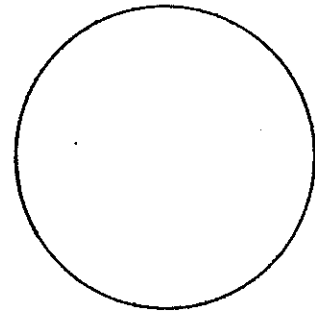

72" Diameter
#11

1/4" SCALE FIGURES

BY MASTER SCULPTOR PETER ADUAN



Leaning Man
unpainted, #3088



Plymouth Engineer
(positioned to fit
our Plymouth Locos)
unpainted, #3087

1/4" SCALE FIGURES

BY MASTER SCULPTOR PETER ADUAN



Seated gentleman
w/derby hat
unpainted, #3030



Cigar store Indian
unpainted, #3038

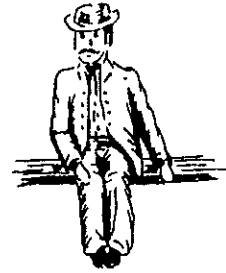

Seated gentleman
w/felt hat
unpainted, #3031



Victorian Lady
unpainted, #3034



Victorian Man
unpainted, #3094



Lady of the evening (c.1890)
unpainted, #3036



1940's "Walking Lady"
Cast Metal
#3096

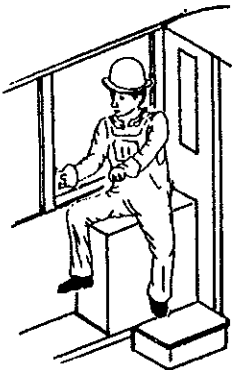

Seated Workman
unpainted, #3040

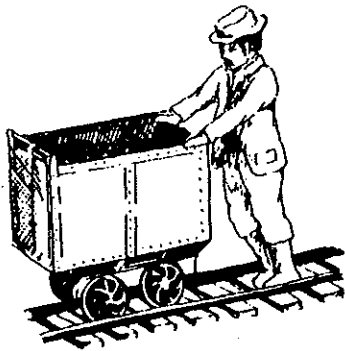

Pushing Workman
unpainted, #3090



Track Worker
unpainted, #3098



Shop keeper
unpainted, #3042

LOCOMOTIVE COMPONENTS

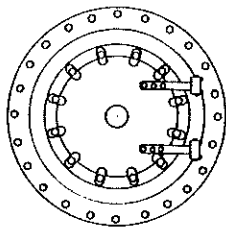

Baldwin Boiler Front
54" Diameter
#2101
in brass only

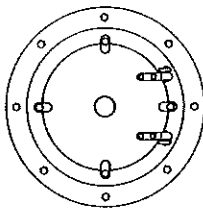

Baldwin Boiler Front
50" Diameter
#2102
in brass only

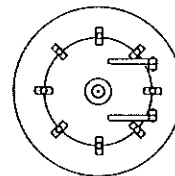

Climax Boiler Front
42" Diameter
#2120
in brass only

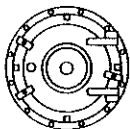

Lima Shay Boiler Front
30" Diameter
#2117
in brass only

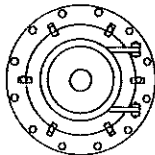

Lima Shay Boiler Front
36" Diameter
#2104
in brass only

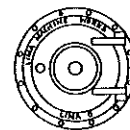

Lima Shay Boiler Front
30" Diameter
Gilpin Tram #2
#2128
in brass only

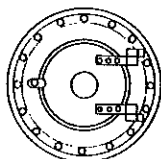

Porter Boiler Front
37 1/2" Diameter
#2103
in brass only



Loco Builders Plates
1890 Porter
#123
in brass, #2123



Loco Builders Plates
1906 Porter
#125

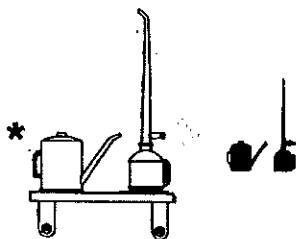

Cab Detail
1 Qt. Pump Oiler
3 Pt. Valve Oil Can
#130

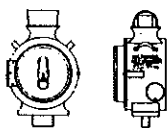

Headlight
18" Oil Burning
#124

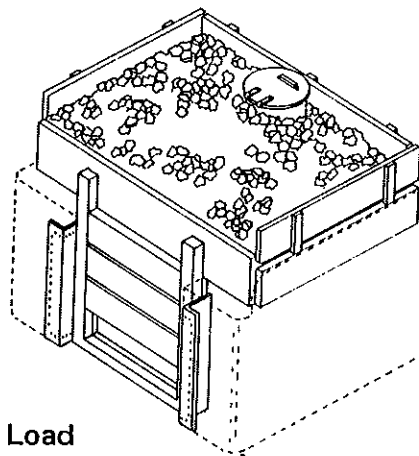

Coal Load
for USH 13 Ton Shay
#110

* enlarged to show detail

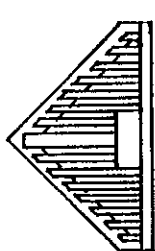

Pilot for Porter or Sm Loco #159



8 Ton Porter Link and Pin Couplers #158



Number Plate Assortment Nos. 1-8 #126



Locomotive Bell 11 1/2" Diameter #105 in brass, #1105

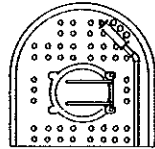

Back Head for Small Loco #117



Tapered Stack Can be used for 8 Ton Porter #161

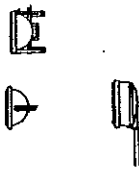

Tail light, Drum headlight for RGS Goose #6, etc. #150



Porter Tender Pedestals Journal boxes Springs #151

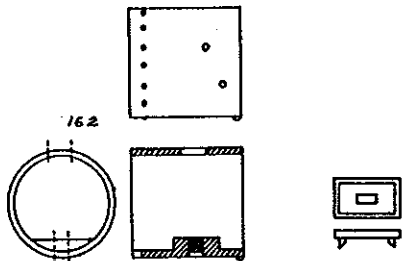

Top mounting Headlight Bracket Extended Smokebox Can be used for 8 Ton Porter #162

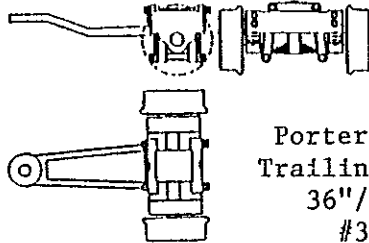

Porter 0-6-2 Trailing Truck 36"/ 30" #3108

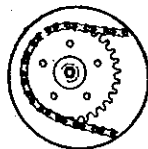

enlarged to show detail



Dummy Chain w/ Sprockets #142

PARTS LIST FOR PORTER 18 TON LOCOMOTIVES

SOLD BY THE BAG AS IN THE KITS (ENOUGH FOR ONE LOCOMOTIVE) OR BY THE SPRUE(S).
 WIRE AND METAL PARTS ARE INCLUDED IN THE BAGS ONLY. THEY ARE NOT AVAILABLE SEPARATELY.

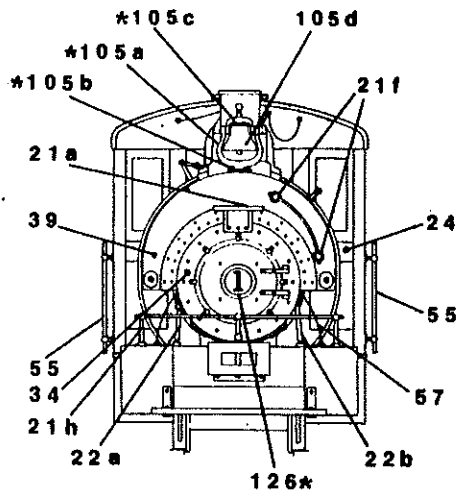

*105 changed to 69
 126 changed to 67

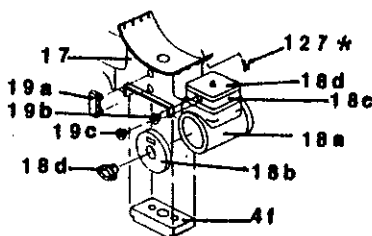
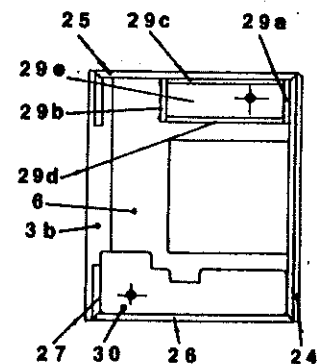
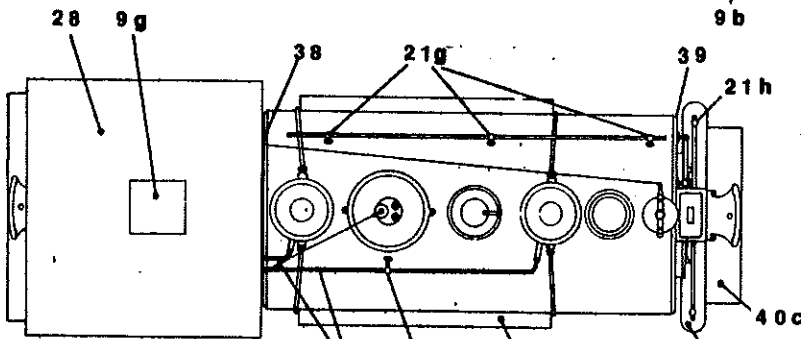
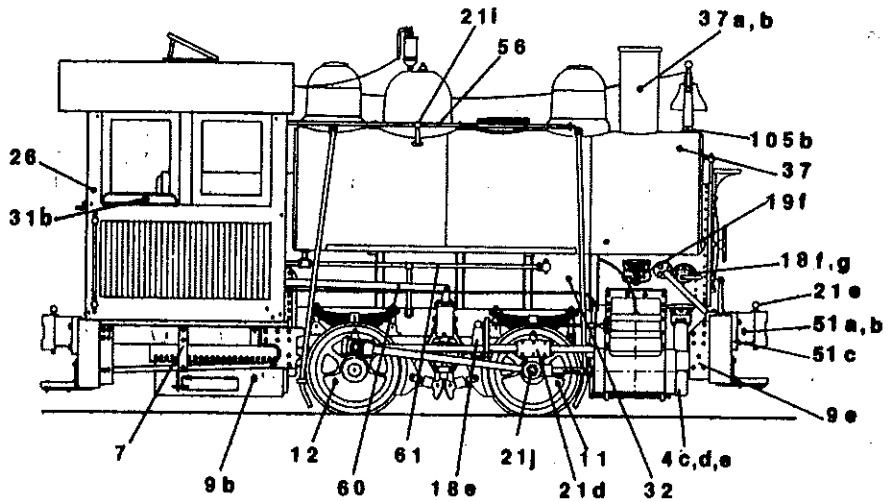
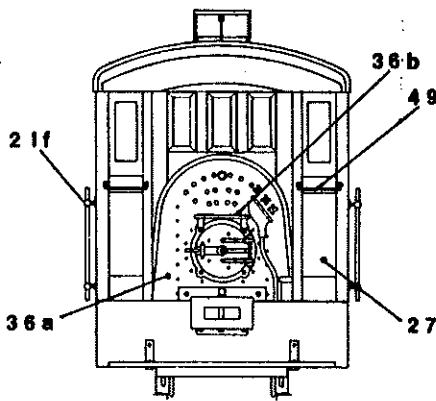
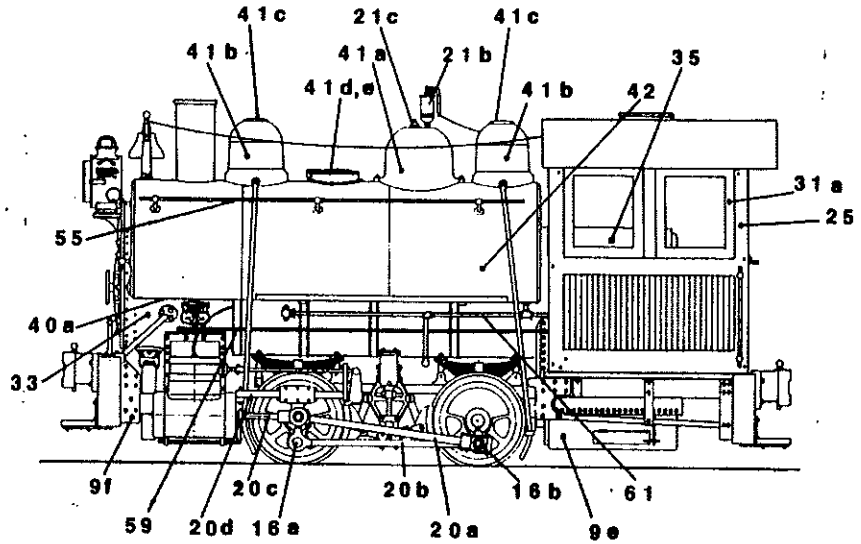

*127 changed to 68

Part No.	Description	Qty
BAG #1	3060-01	
3060-1	Frame	2
3060-2	Fire Box Front	1
3060-3a	Front Pilot Beam	1
b	Rear Pilot Beam	1
3060-4a	Front Frame Crossmember	1
b	Equalizer Bar	1
c,d,e	Cinder Clean-out Pipe	1
f	Cylinder Block Mounting Block	1
3060-5a	Brake Bracket	2
b	Brake Shoe Assembly	2
c	Brake Cylinder	2
d	Brake Cylinder Cap	2
BAG #2	3060-02	
3060-6	Cab Floor	1
3060-7	Rear Frame Extensions (R,L)	1
3060-8a	Fire Box (Upper Right)	1
b	Fire Box (Upper Left)	1
3060-9a	Fire Box (Lower Rear)	1
b	Ash Pan (Right)	1
c	Ash Pan (Left)	1
d	Ash Pan (Rear)	1
e	Front Pilot Bracket (Right)	1
f	Front Pilot Bracket (Left)	1
g	Cab Roof Vent	1

Part No.	Description	Qty
3060-10a	Ash Pan Bottom	1
b	Crosshead Yoke	1
c	Water Pipe Connector	1
3060-51a	Coupler Pocket (Upper)	2
b	Coupler Pocket (Lower)	2
c	Coupler Pocket Flange	2
d	Smoke Box Front Nut Retainer	1
3060-75	Coupler	2
BAG #3	Price: \$28.50 3060-03	
3060-11	Drivers (Front)	2
3060-12	Drivers (Rear)	2
3060-13	Geared Axle	1
3060-14	Plain Axle	1
3060-15	Journals	4
3060-16a	Crank Pin Retainer Front	2
b	Crank Pin Retainer Rear	2
c	Crank Pin Rear Spacer	2
BAG #4	3060-04	
3060-17	Cylinder Block	2
3060-18a	Cylinders	2
b	Cylinder Cap (Rear)	2
c	Valve Chest	2
d	Valve Chest Cover	2
e	Valve Levers	2
3060-19a	Cylinder Block Connecting Flange	2
b	Valve Stuffing Box Front	2
c	Valve Stuffing Box Rear	2
d	Cylinder Stuffing Box	2
e	Sander Pipe Brackets	4
f	Bulldozers Plates	2
3060-20a	Main Rod	2
b	Side Rod	2
c	Piston Rod	2
d	Cross-head Guide	2
3060-21a	Headlight Bracket (Front Mount)	2
b	Whistle	2
c	Pop Valves	4
d	Cross-heads	2
e	Coupler Pins	2
f	Hand-rail Posts (Short)	6
g	Hand-rail Posts (Med.)	4
h	Hand-rail Posts (Long)	4
i	Sander-rod Post	2
j	Main Rod Pivot Pin	2
3060-22a	Front Pilot Brace (Right)	1
b	Front Pilot Brace (Left)	1
c	Valve Reverse Lever	1
d	Valve Reverse Spring Rod	1
3060-68	1 1/2" Hex Nuts	16
3060-58	Valve Stem	2
3060-59	Blower Pipe (.020 wire)	1
3060-60	Reach Rod	1
3060-61	Injector Delivery Pipe	2
BAG #5	3060-05	
3060-24	Cab Front	1
3060-25	Cab Side (Left)	1
3060-26	Cab Side (Right)	1
3060-27	Cab Rear	1
3060-28	Cab Roof	1
3060-29a	Coal Box (Front)	1
b	Coal Box (Rear)	1
c	Coal Box (Left)	1
d	Coal Box (Right)	1
e	Coal Box (Bottom)	1
3060-30	Cab Sub Floor	1
3060-31a	Cab Window Frames	4
b	Arm Rest	1
BAG #6	3060-06	
3060-32	Boiler	1
3060-33	Smoke-Box	1
3060-34	Smoke-box Front	1
3060-35	Rear Boiler Section	1
3060-36a	Back-head	1
b	Oil-can Shelf	1

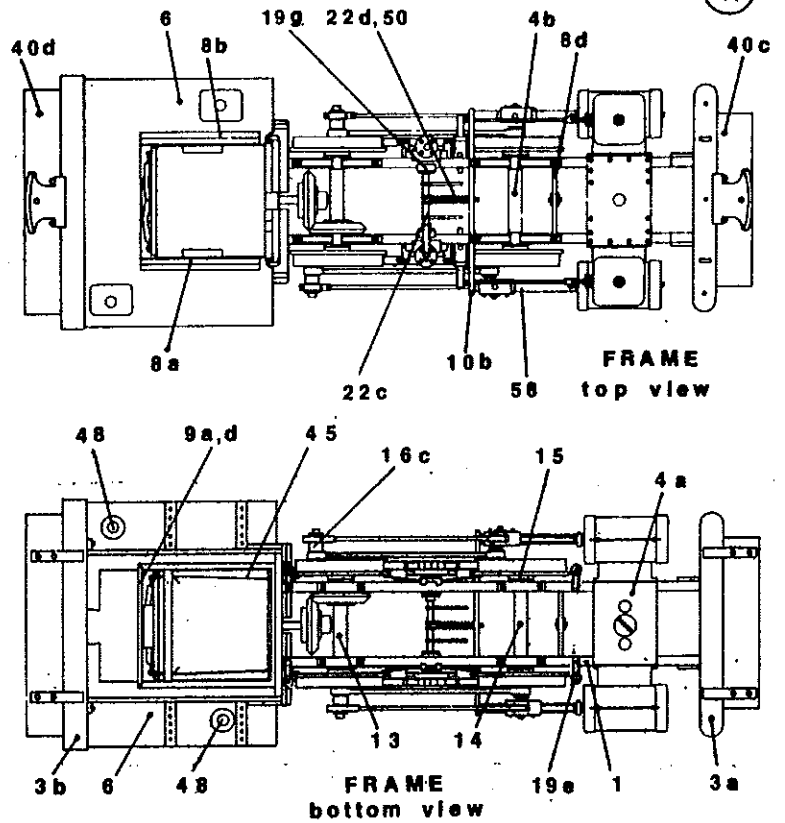

Part No.	Description	Qty
3060-37a,b	Stack with Base	1
3060-66 a	Headlight Body	1
b	Headlight Bezel/Reflector	1
c	Headlight Vent Hood	1
3060-67	Number Plate Assortment	1
BAG #7	3060-07	
3060-37	Water Tank Body	1
3060-38	Water Tank (Rear)	1
3060-39	Water Tank (Front)	1
3060-40a	Water Tank Bottom	2
b	Running Board	2
c	Pilot Step (Front)	1
d	Pilot Step (Rear)	1
3060-41a	Steam Dome	1
b	Sand Dome	2
c	Sand Dome Covers	2
d	Water Hatch	1
e	Water Hatch Cover	1
3060-42	Sander Pipe	4
3060-55	Handrail Wire (.025x4")	3
3060-56	Sander Rods (.020 wire--preformed)	1
3060-57	Lubricator Pipe (.010x2" wire)	1
3060-69 a	Bell Bracket	1
b	Bell Bracket Base	1
c	Bell Trunnion	1
d	Bell	1

BAG #8		(Available as a complete bag only)
3060-43	Headlight Handle Material (.005x .025 x 0.7 long)	3060-08 1
3060-44	Front Pickup (.005 x .040 x .7 long)	2
3060-45	Rear Pickup (.995 x .060 x 1.2 long)	2
3060-46	Front Assy. Screw (2-56 x 5/8)	1
3060-47	2-56 Hex Nut	1
3060-48	#1 Self-tapping Screws	2
3060-49	Grab Irons	2
3060-50	Valve Lever Spring	1

KIT NO. 3061
18 TON PORTER CAB DETAIL KIT

Part No.	Description	Qty		Description	Qty
3061-01	Turret and Related Parts		3061-06	Detroit Lubricator and Misc. Parts	
a	Turret	1	a	Lubricator Body	1
b	R and L Injector Steam Lines (lagged) and Globe Valves	1 set	b	Mounting Bracket	1
c	Gauge Stand	1	c	Supply Line Globe Valve	1
d	Steam Gauge	1	d	Steam Valve Handle	1
e	Gauge Lamp	1	e	Sander Operating Rod Handles	2
3061-02	Injector	2 sprues	3061-07	Throttle and Oil Cans	
a	Injector Body	2	a	Throttle Quadrant	1
b	Waste Pipe	2	b	Throttle Lever	1
c	Delivery Pipe	2	c	1Qt. Pump Oil Can	1
3061-03	Related Parts for Injector		d	1½ Pint Valve Oil Can	1
a	Injector Suction Pipe (right)	1	3061-08	Reverse Lever	
b	Injector Suction Pipe (left)	1	a	Reverse Lever with Rear Quadrant Section	1
c	Blower Valve and Pipe	1	b	Front Quadrant Section	1
3061-04	Water Glass and Piping	1	c	Operating Rod	1
3061-05	Brake Valve Parts		3061-09	Valve Handle Assortment	18
a	Body and Piping (lagged)	1	3061-10	Cab Seats	
b	Valve Handle	1	a	Engineer's Seat Box Front	1
c	Lunkenheimer Lubricator	1	b	Engineer's Seat Box Rear	1
d	Globe Valve	1	c	Engineer's Seat Box Ends	2
e	Waste and Brake Lines	2	d	Engineer's Seat Box Cushion	1
			e	Fireman's Seat	1
			3061-11	Brass Bell	1

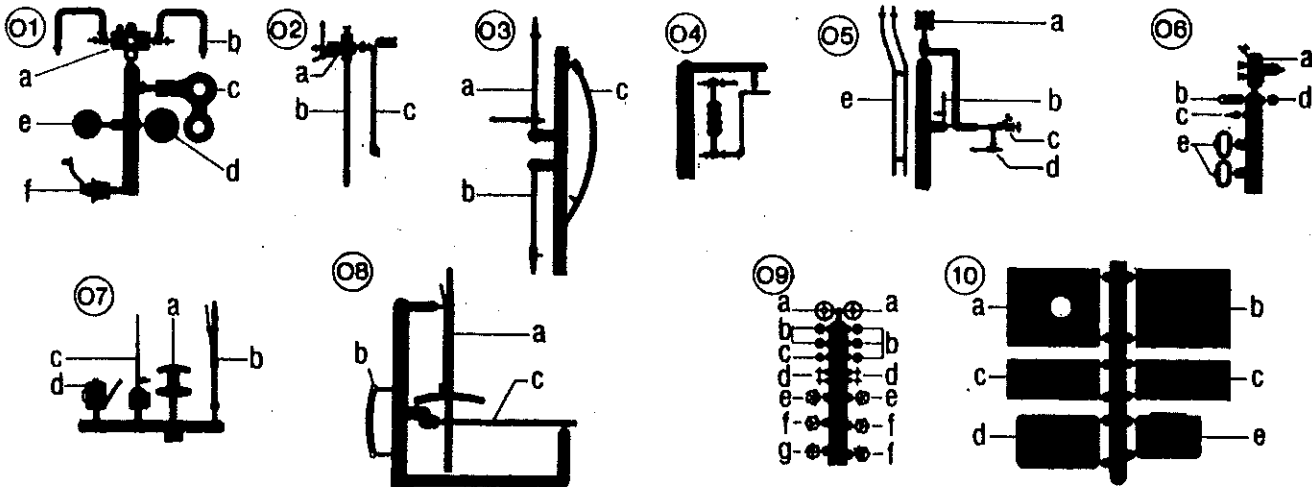
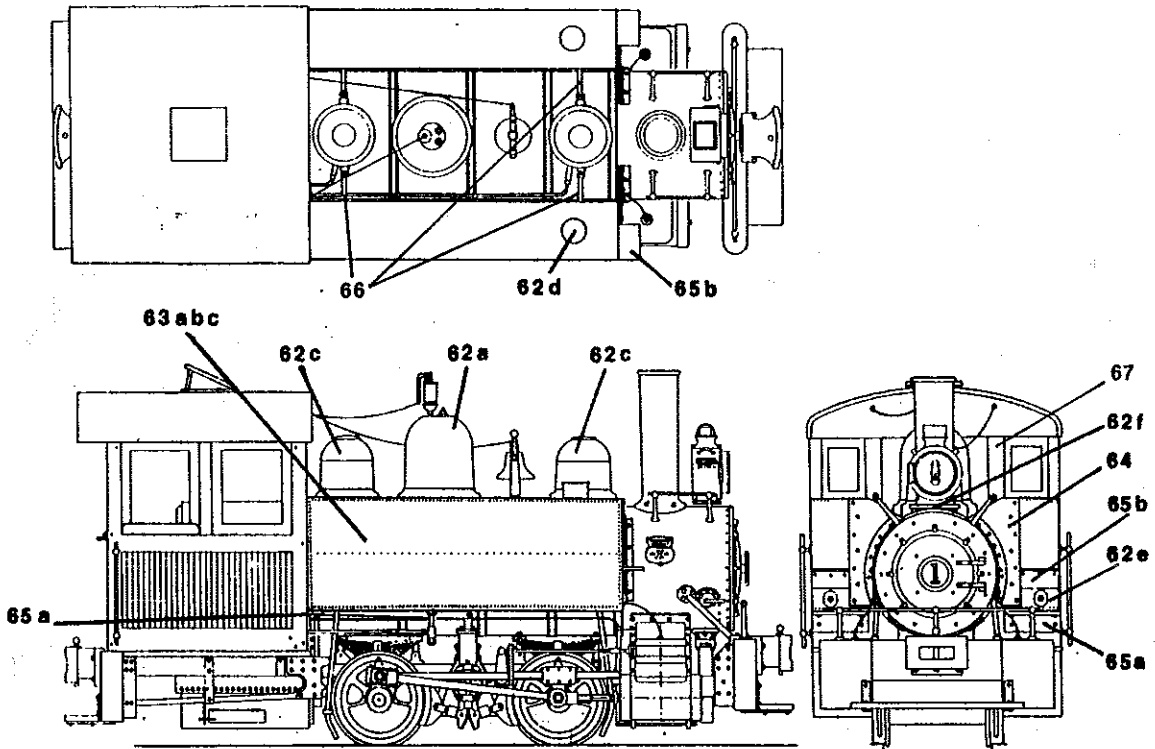

ILLUSTRATION OF CASTINGS CONTAINED IN KIT

KIT NO. 3062

PORTER 18 TON 0-4-0 ST RECTANGULAR SIDE TANK



Miscellaneous Parts Available

3062-62	Domes Curved to Fit Boiler	3062-64	Front Tank Supports (Right, Left) for Rectangular Tanks	1	
a	Steam Dome	1			
b	Steam Dome Locating Ring	1			
c	Sand Domes	2	3062-65	Rear Bracket/Front Step	
d	Tank Filler Caps	2	a	Rear Tank Support Angle	2
e	Tank Clean-out Plugs	2	b	Front Step for Tank	2
f	Headlight Bracket--Top Mount	1	3062-66	Sander Pipe	4
3062-63	Rectangular Side Tanks -- 600 gal.	3062-67	Cab Front	1	
a	Sides	4			
b	Top/Bottom	4			
c	Ends	4			

TRANSMISSION PARTS FOR PORTER LOCOS

7062	Micro-Mo Motor and Gear for #3060 Porter	7065	Motor and Adapter Kit 30" Gauge (Complete)		
7064	Motor and Adapter Kit 24" Gauge (Complete)	7065-01	Frame Spacer	set	
7064-01	Frame Spacer	7065-02	Geared Axle	1	
7064-02	Geared Axle	7065-03	Plain Axle	1	
7064-03	Plain Axle	7065-04	Micro-Mo Motor with Gear	1	
7064-04	Micro-Mo Motor with Gear	1	7066	Motor and Adapter Kit 42" or S Gauge	
			7066-01	Spacer Washers	4
			7066-02	Geared Axle	1
			7066-03	Plain Axle	1
			7066-04	Micro-Mo Motor with Gear	1

MINING AND CONSTRUCTION EQUIPMENT

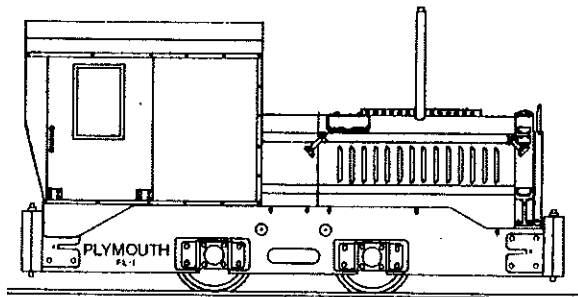
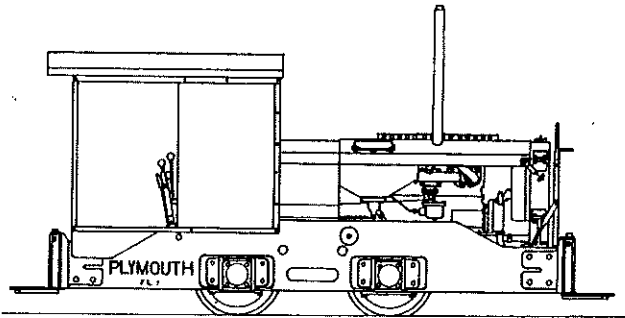

Plymouth FL-1 Six Ton Locomotive
Unpowered On2 Kit #3019

Plymouth FL-1 Five Ton Industrial Locomotive
Powered Kits: On30 #7059
On3 #7060
On2 #7061

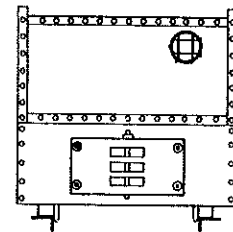
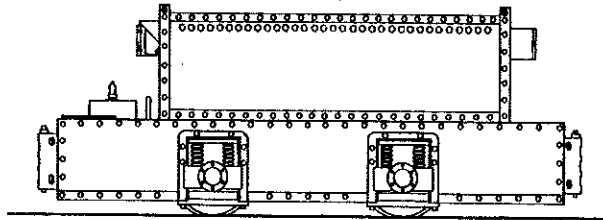
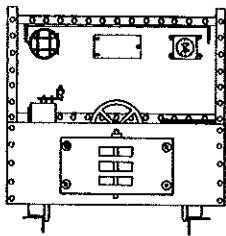

Storage Battery Mine Locomotive
Unpowered On3 Kit #3053

Motor, Gears, Drive, Pick-ups
On30 KIT #7052 On3 KIT #7053

Many mining companies made use of storage battery powered locomotives for haulage, occasionally running them from the mine heading out to the ore bins or tipples. Storage battery locomotives ran in size all the way from the little "trammers" to machines weighing over ten tons. This kit is for a fairly large one to accommodate a geared Micro-Mo motor for a possible power source, and is a composite of several locomotives used by the mining industry throughout the world.

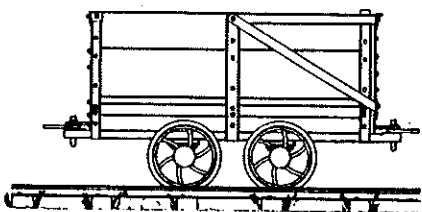
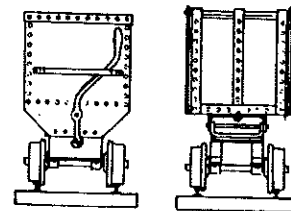
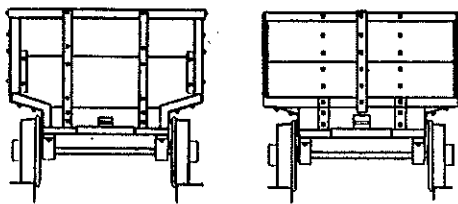

Plymouth Engineer
(positioned to fit
our Plymouth Locos)
unpainted, #3087

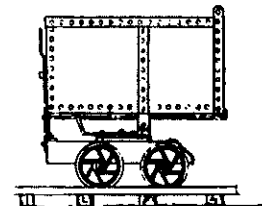

1 Ton End Dump Coal Car
#3052

Link and Pin Couplers
Delrin
#147

Rotary Mine Car
18" Gauge
#3024
in brass, #2124

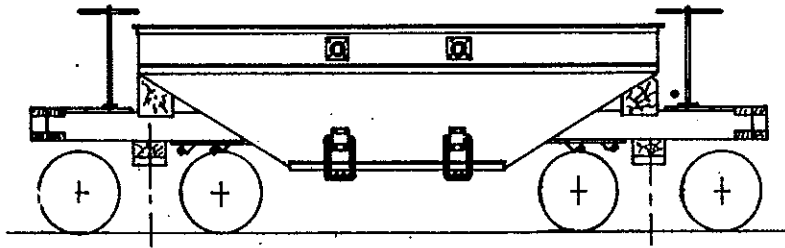

Gilpin Tram Large Ore Car
Less Trucks
#3050

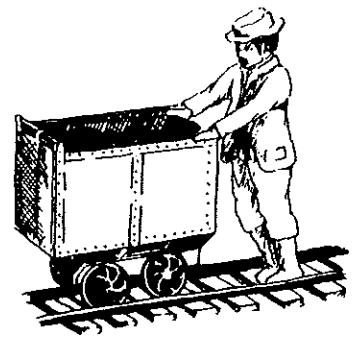

Painted "Cousin Jack"
with #3024 Rotary Ore Car
and Track
#3092

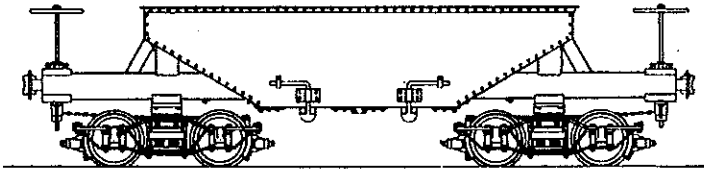

Gilpin Tram Small Ore Car
Less Trucks
#3018

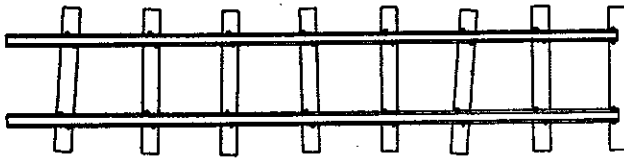
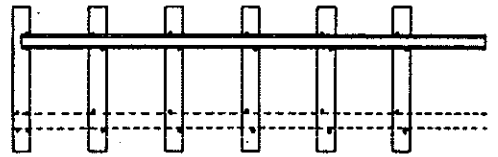

Mine Track
18" Gauge
#3044

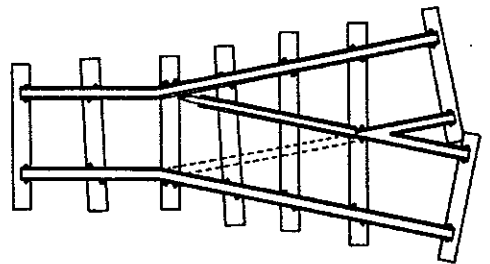

Mine Track Curve, Switch
18" Gauge
#3045

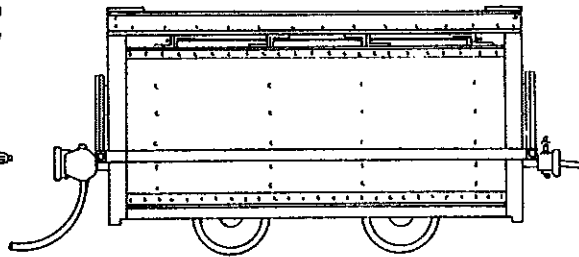
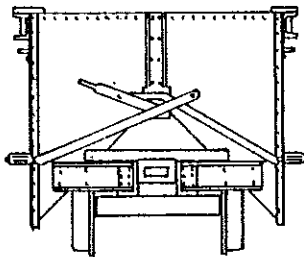

Koppel 3- $\frac{1}{2}$ yd
Gable Bottom Dump Car
On2, #3100
On30, #3101
On3, #3102

Fairbanks-Morse
#37 Dump Car
in On3*
#3103

*can be adapted
to On30

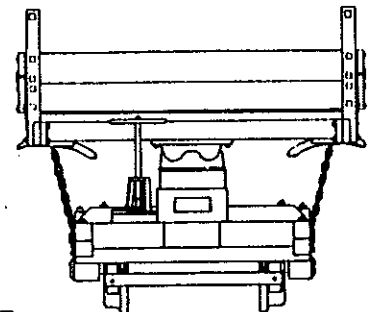
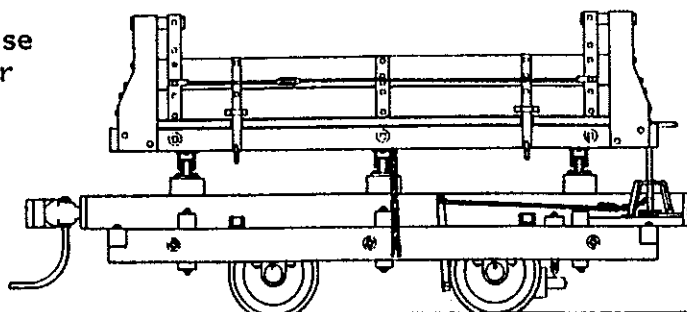

suitable to be pulled by our 18 ton Porter

Handwritten notes on the left margin, including a large 'S' and some illegible scribbles.

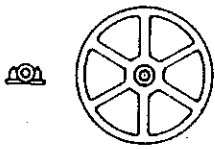

Cable Sheave, Bearings
34" Diameter
#3525

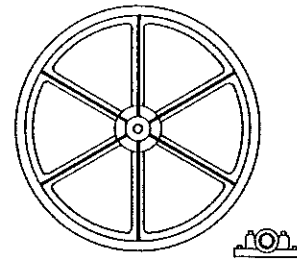

Head Frame Sheave
with Bearings
60" Diameter
#3511

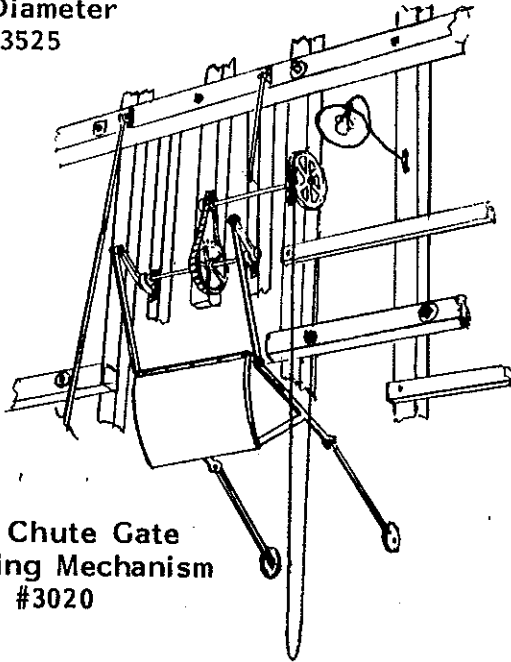

Coal Chute Gate
Operating Mechanism
#3020

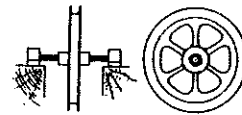

Cable Sheave, Bearings
24" Diameter
#3515

TRACK COMPONENTS

THESE ARE MADE IN 1/4" SCALE, BUT MAY BE USED IN OTHER SCALES



Code 70 Fish Plates
(Dummy)
#9003



Code 100 Tie Plates
#9002

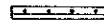

Code 100 Fish Plates
(Dummy)
#9004



Code 125 Tie Plates
#9001



enlarged to show detail

Spike Heads
(for cosmetic purposes only)
#9007



Link and Pin Couplers
Gilpin Tram
#72
in brass, #1072

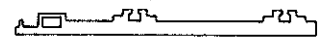

Stub Switch Bridle
Code 100, 24" x 36"
#9006



TRACKSIDE DETAILS

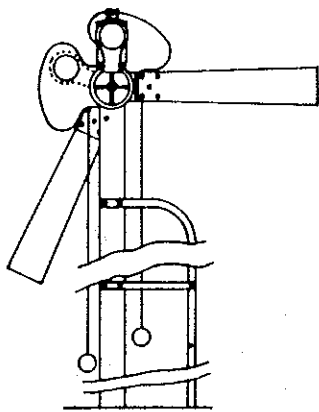

Harrington Semaphore
Order Board
#3047
in brass, #2129

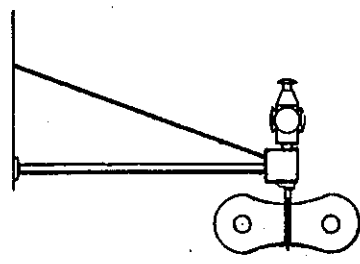

Station Order Board
Rotary Type for Colorado
Narrow Gauge Roads, etc.
#3028

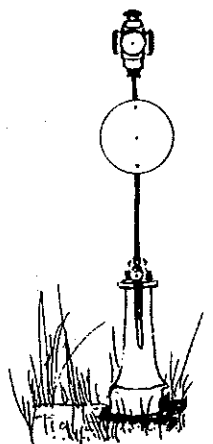

Switch Stand
Heavy Cast Iron
#3021
in brass, #2126



Marker Lamps for
Caboose, Switch Stands, Order Boards
cast in clear plastic
will accept PFM 1.5v. bulbs
#149

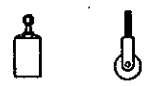
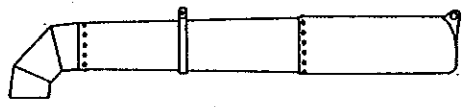

Water Spout, Pulleys,
and Counterweights
white metal
#3104

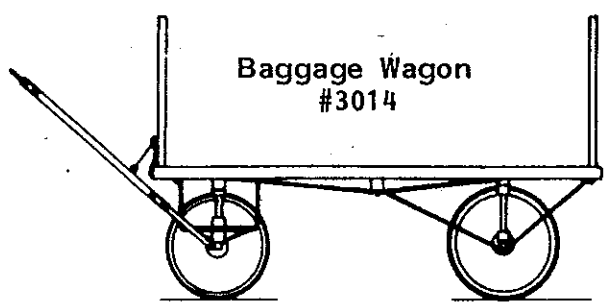

Baggage Wagon
#3014

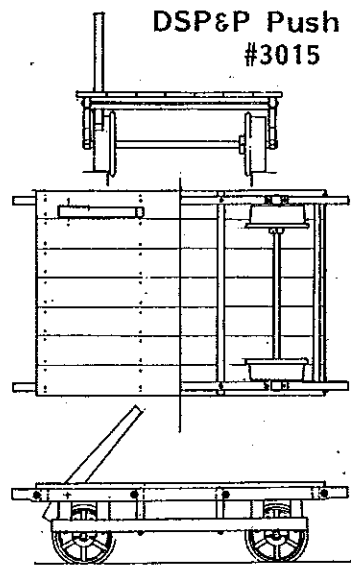

DSP&P Push Car
#3015

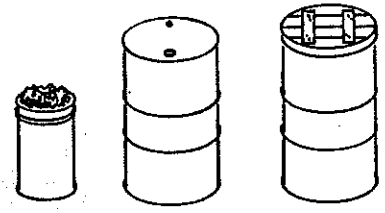

55 Gallon Drums
Fire Barrel Lids, Spike Cans
#3013

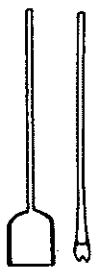

#3554
Spade, Clawbar
Delrin

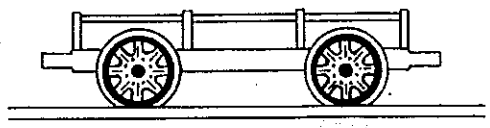

D&RGW Fairmont Push Car
36" Gauge
#3012

TRANSMISSION COMPONENTS

All gears and transmission parts are cast in Delrin^R
unless noted otherwise

All parts are drawn actual size, unless noted otherwise.
Where enlargement is used to show detail, a silhouette shows actual size.

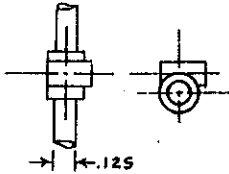

Climax Cross Boxes
#7079

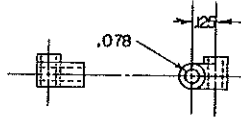

Cross Box
for #7077 Gears
#7033



Shaft Coupling
3/32" and .078" Bores
Flexible Delrin
#7008

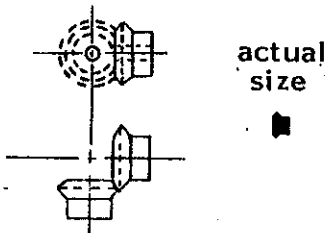

Bevel Gear
8 Tooth
1/8" OD, 1/32" Bore
#7007

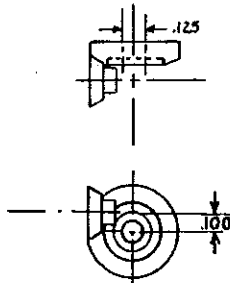

2:1 Skew Bevel Gears
.062" and .125" Bore
.100" Offset
#7078

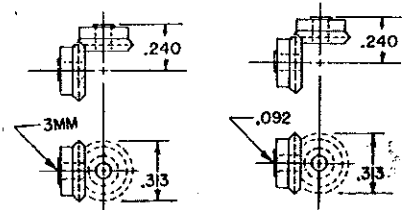

1:1 Bevel Gears, in line
15 Tooth
.3mm Bore, 48 DP
#7034
with 3/32" Bore, #7035

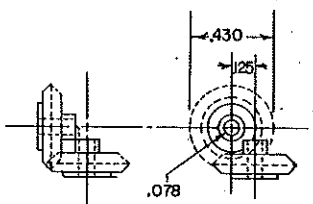

1:1 Skew Bevel Gears
.078" Bore, .125" Offset
#7077

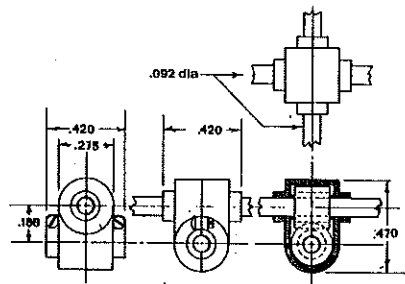

1:1 Helical Gears
.1875" Offset Delrin Gearbox
.078" Coupling
#7038

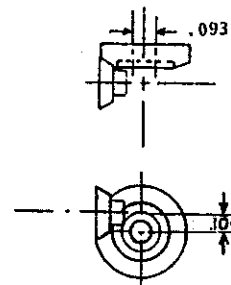

2:1 Skew Bevel Gears
.062" and .093" Bore
.100" Offset
#7012

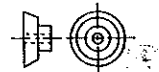

Brass Bevel Pinion
12 Tooth, 48 DP
#7083

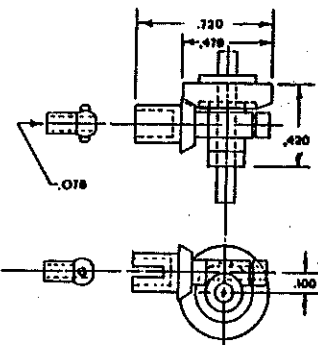

2:1 Ratio Gears, Cross Box
.078" Bore U-Joint
1/8" Axle #7086
3mm Axle #7085

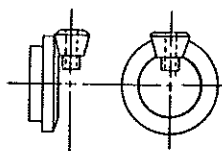

Shay Gear Set
for 26" and 29" Drivers
#7041

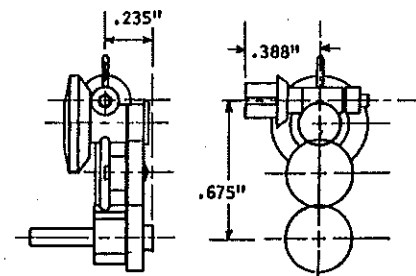

4:1 Ratio Gear Tower
.078" Bore U-Joint
3/32" Axle Bore
(wheels not included)
#7013

0782

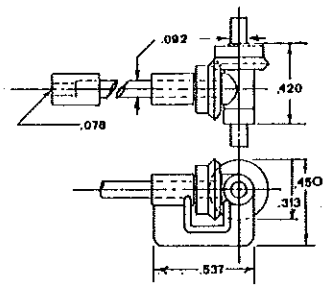

**1:1 Gears--In line
Mounting Bracket
.089" Coupling
3/32" Axle Material
(will clear wheels as small as
.320" Diameter, 24" Gauge)
#7037**

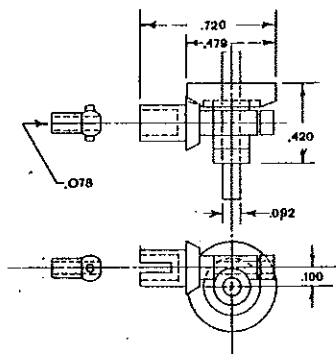

**2:1 Ratio Gears, Cross Box
.078" Bore U-Joint
3/32" Axle Material
(Wheels not included)
#7036**

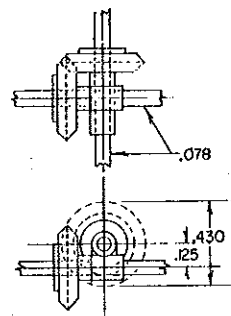

**1:1 Skew Bevel Gears
1/8" Offset
.078" Bore Cross Box
with Axle Material
#7040**

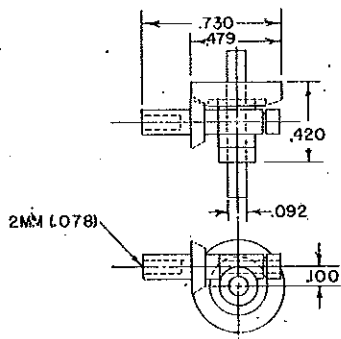

**2:1 Ratio Gears, Cross Box,
.078 Coupling
3/32" Axle Material
Without Wheels, #7030
With 2 24" Spoked Wheels, #7031**

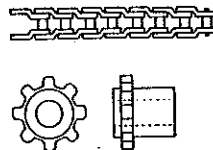

**Chain and Sprocket Set
8 Tooth
#7006**

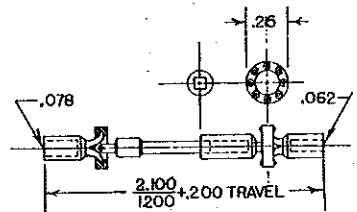

**Universal Joint Set
for Climax
#7039**

Bore .093"  Bore .093"
Minimum Length (pair) 1.250 inches

**Universal Joint
#7009**

Bore .093"  Bore .118 (3mm)
Minimum Length (pair) 1.250 inches

**Universal Joint
#7004**

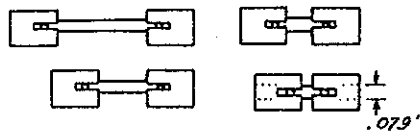

**Universal Joints
0.6" to 1.0" overall length
to fit .079" (2mm) Shafts
#7011**

Bore .093"  Bore .078 (2mm)
Minimum Length (pair) 1.250 inches

**Universal Joint
#7010**

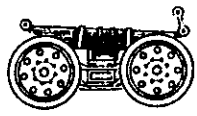
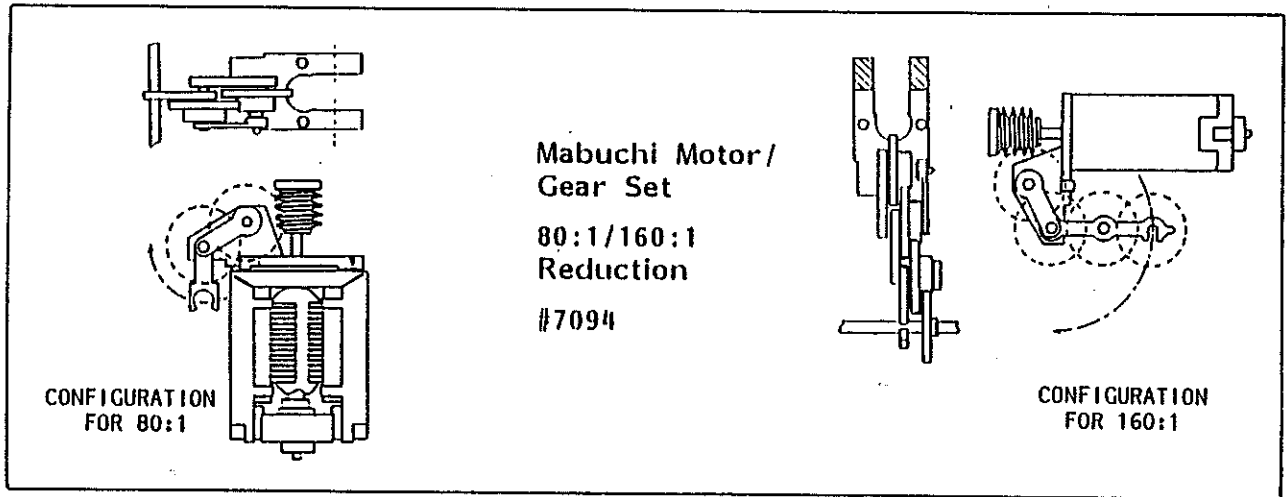

When pairing two universal joints, always keep the pins in the same plane to maintain constant velocity.

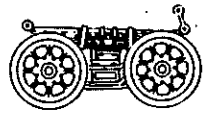
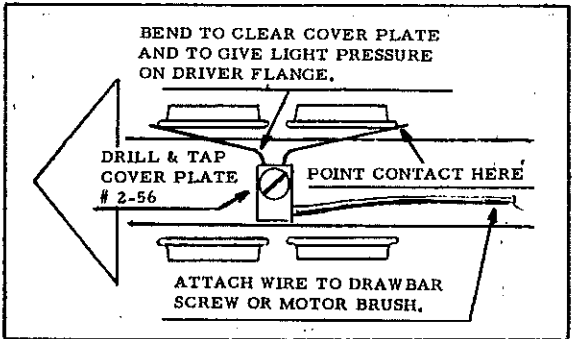

Pilot Truck for
Galloping Goose
#7071

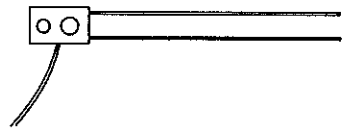

Pilot Truck for
Galloping Goose
#7072



Electrical Pick-up
Locomotive Drivers
7005

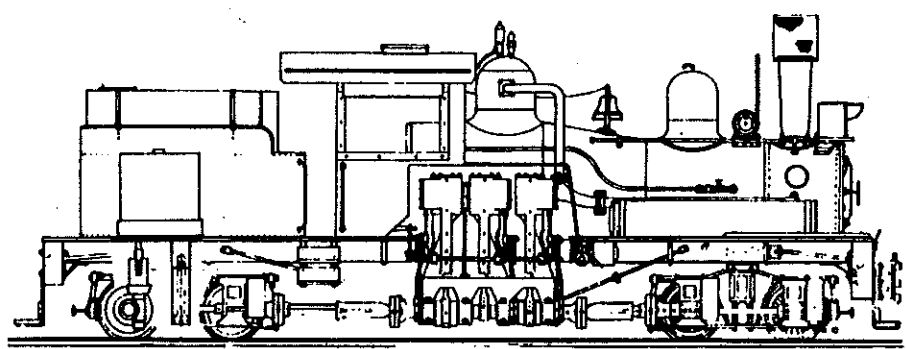

Micro-Mo Motor and Gearing
for Kemtron Shay
#7051

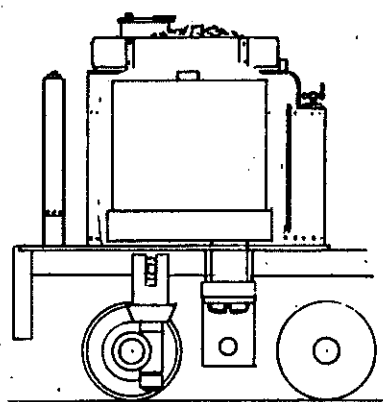

Micro-Mo Motor and Gearing
for USH 13 Ton Shay
Includes Coal Load to Cover Motor
#7050

NOW AVAILABLE.....

DELTRIN SPROCKETS AND CHAIN

CHAIN

Catalog # 70001 \$5.00 / package
 packaged in 6" length
 links can be combined or removed
 to create different lengths

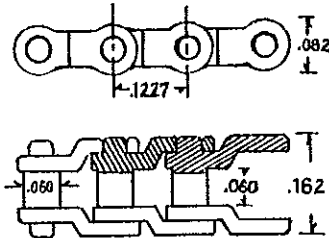

SPROCKETS

Packaged 1 / package

Material is black Dupont Delrin 500
 (acetal resin)

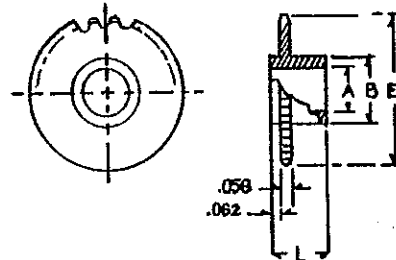

TEETH	CATALOG NUMBER	NOMINAL SHAFT HOLE "A"	OUTSIDE DIA. "E"	PITCH DIA.	PRICE EACH
8	70082	.125	.371	.318	\$1.25 each
9	70092	.125	.409	.356	1.25
10	70102	.125	.456	.394	1.25
12	70122	.125	.535	.471	1.50
15	70152	.125	.650	.586	1.50
15	70153	.1875	.650	.586	2.75
16	70162	.125	.690	.625	1.50
18	70182	.125	.789	.702	1.75
20	70202	.125	.848	.780	1.75

B = A + .125 for all except #70082, where B = .236
 L = .312 for all

NOTE: OTHER SIZES MAY BE AVAILABLE BY SPECIAL ORDER. CALL FOR MORE INFORMATION

TRUCKS & WHEELS

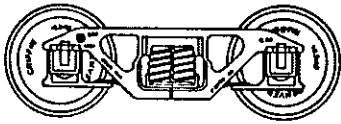

D&RGW Andrews Truck
 56" Wheelbase
 5900 Stock, 150 Reefer, 6500 Flat
 Brown Delrin, #3073
 Black Delrin, #3074

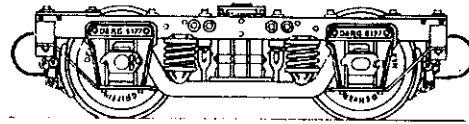

Basic Truck with Brake Rigging (Kit #3057) Added

**D&RGW Pullman-style
 Passenger Car Truck**
 Wood Bolsters (less brake rigging)
 #3054

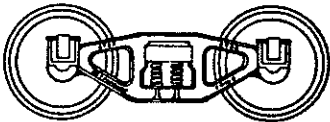

Bettendorf Truck, 54"
 Brown Delrin
 C&S/RGS/WP&Y
 #3029

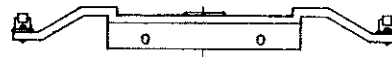

with Composite Wood & Steel
 Outside Bearing Bolster
 #3055

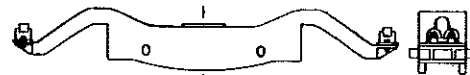

with Cast Steel Outside
 Bearing Bolster
 #3056

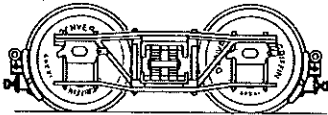

D&RGW Caboose Truck
 3'7" Wheelbase
 Brown Delrin
 #3076

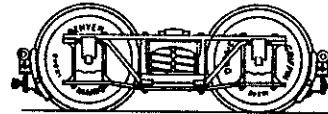

D&RGW Archbar Trucks
 3'7", Non-magnetic Wheels, Axles
 Brown Delrin
 #3023
 Black Delrin
 #3027

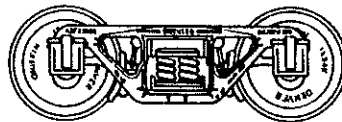

D&RGW Cast Steel Truck
 for Frameless Tank Car
 4'8" Wheelbase
 Black Delrin
 (unassembled)
 #3078



SR&RL Archbar Truck
 4' Wheelbase
 2' Gauge
 Black Delrin
 #3075

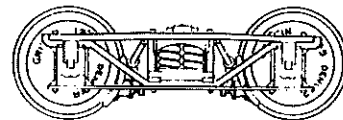

D&RGW Archbar Truck
 4'8" Wheelbase
 Brown Delrin
 #3077

UNMACHINED DRIVERS AND WHEELBLANKS

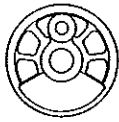

Baldwin Driver Centers
28" Diameter
in brass
#2110

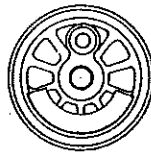

Baldwin Driver Centers
36" Diameter
D&RGW C-16
in brass
#2115

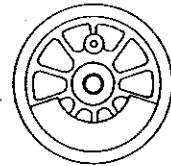

Baldwin Driver Centers
45" and 46" Diameter
D&RGW T-12
in brass
#2113

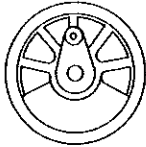

C&S Mogul Driver Centers
37" Diameter
in brass
#2107

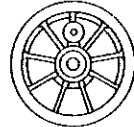

Hinkley Driver Centers
for 2" Gauge Forney
33" Diameter
in brass
#2108

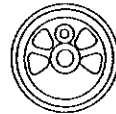

Porter Driver Centers
24" Diameter
in brass
#2109

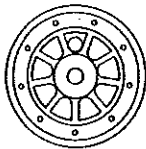

DSP&P Driver Centers
Mason Bogie, 37" Diameter
in brass
#2106

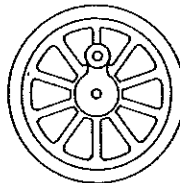

Mason Bogie
Driver Centers
42" Diameter
in brass
#2112

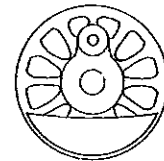

Schenectady Driver Centers
42" Diameter
RGS #20
in brass
#2121

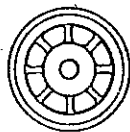

28" Wheel Blanks
Nickel Silver Only
#1092



24" Wheel Blanks
Nickel Silver Only
#1096

PILOT WHEELSETS--FLUSH AXLES

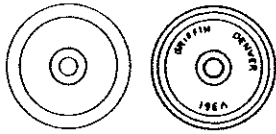

28" Pilot Wheelset
Metal Rims, Axles
#87

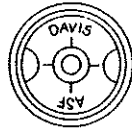

28" ASF-Davis Pilot Wheels
36" Gauge
#91

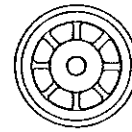

28" Pilot Wheels, 8-spoke
36" Gauge
#92

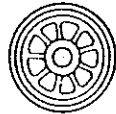

24" Pilot Wheels
9-spoke, 36" Gauge
#96



Griffin Denver Pilot Wheelset
24" Diameter, 36" Gauge
#56

TRUCK WHEELSETS--BLUNT AXLES

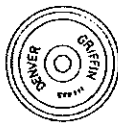

Griffin Denver 26" Wheelset
for Scenery only (all plastic)
36" gauge
#45



Griffin Denver 24" Wheelsets
36" Gauge
#55



Griffin Boston 20" Wheelsets
24" Gauge
#57

Griffin Boston 20" Wheelsets
36" Gauge
#58

RAILCAR WHEELS ARE CAST IN DELRIN^R OR NICKEL SILVER



"Cast Iron" Railcar Wheels
18", 9-spoke
#34
Nickel Silver, #1034



"Cast Iron" Railcar Wheels
18", 8-spoke
#35
Nickel Silver, #1035



"Cast Iron" Railcar Wheels
20", 8-spoke
#36
Nickel Silver, #1036



"Cast Iron" Railcar Wheels
20", 9-spoke
#37
Nickel Silver, #1037



"Cast Iron" Railcar Wheels
20", 10-spoke
#38
Nickel Silver, #1038



"Cast Iron" Galloping Goose
Pilot Wheel--16"
Silver Delrin
#135

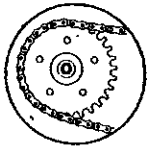

enlarged to show detail



Westside Lumber Co. Pushcar
or Model T Speeder Wheels
with Drive Chain
#42
Nickel Silver Wheels #1042
Brass Chain, Sprocket #1110



Sheffield Railcar Wheels
"Pressed Steel", 20"
#39
Nickel Silver, #1039



Fairmont Railcar Wheels
"Pressed Steel", 16"
#40
Nickel Silver, #1040

WAGON WHEELS

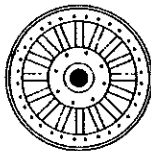

Circus Wagon Wheels--Plain
#30

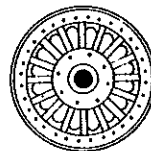

Circus Wagon Wheels
Sunburst
#31

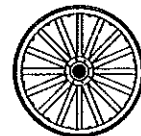

Popcorn Wagon Wheels
#32

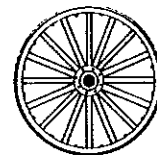
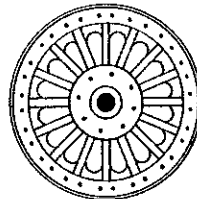
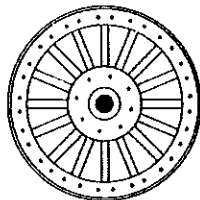

Metal Wheelsets with Plastic Axles



14" Wheelsets
3' Gauge
#131



18" Wheels, Code 94
3' Gauge
#133

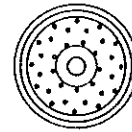

28" Paper Wheelsets
Metal Rims, Axles
#85

14" Wheelsets
2' Gauge
#132

18" Wheels, Code 94
2' Gauge
#134

WHEELSETS

Driver Rims, 40" Diameter *D&RGW K-27* #7080

Driver Rims, 29" Diameter *Lima Shay* #7043

We will supply wheel rims as used in our wheelsets. These must be bored to suit your needs.

- 33" Diameter #7044
- 28" Diameter #7045
- 26" Diameter #7046
- 24" Diameter #7047
- 20" Diameter #7048
- 40½" Diameter #7049

S
•
1:64
•
S
•
1:64
•
S
•
1:64

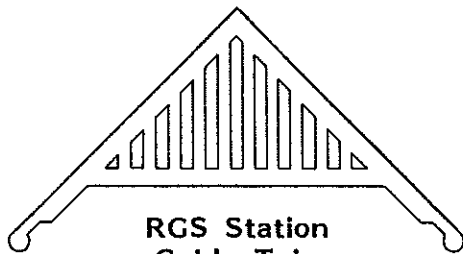

RGS Station
Cable Trim
#4034

Ophir Depot



RGS Station
Roof Cresting, Finials
#4035

Ophir Depot

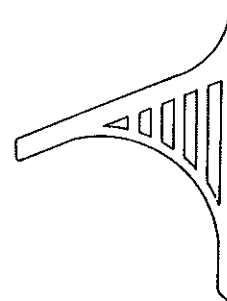

RGS Station
Eave Trim
#4033

Ophir Depot

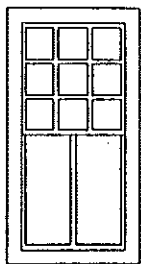

RGS Style Depot Windows
11 Pane, 36" x 76"
#4032

Ophir Depot

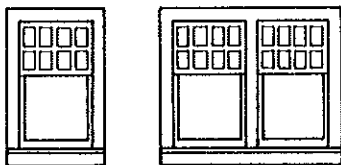

RGS Style Depot Windows
9 Pane, 32" x 52"
18 Pane, 60" x 52"
#4037

Ophir Depot

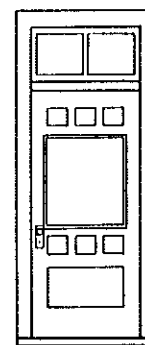

RGS Style Depot Door
w/ Window, Transom
#4039

Ophir Depot

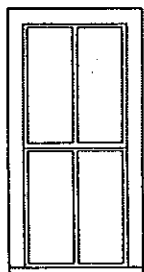

RGS Station Depot Windows
4 Pane, 36" x 82"
#4036

Ophir Depot

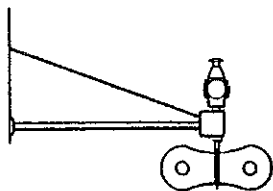

Station Order Board
Rotary Type
#4061

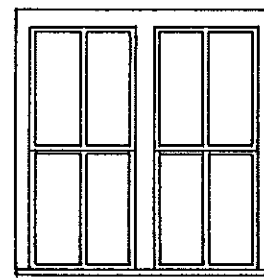
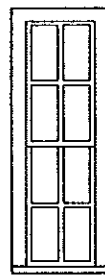

RGS Station Depot Windows
4 Pane, 24" x 82"
8 Pane, 72" x 82"
#4038

Ophir Depot

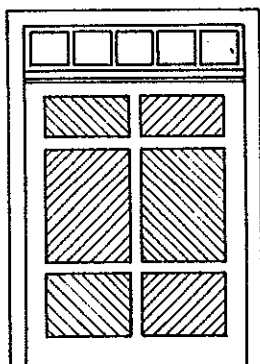

RGS Style Depot
Freight Door, Transom
#4040

Ophir Depot

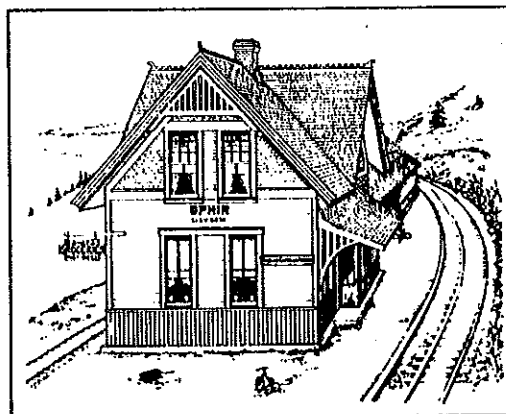

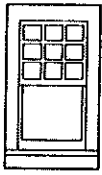

RGS Style Depot Windows
10 Pane, 32" x 54"
20 Pane, 58" x 60"
#4041

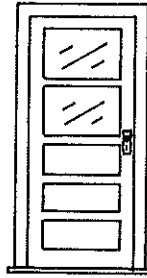
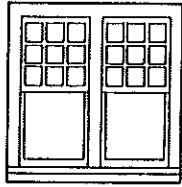

36" Door
#4025

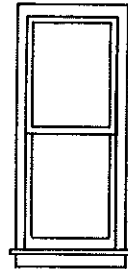

Double Hung Window
30" x 78"
#4024

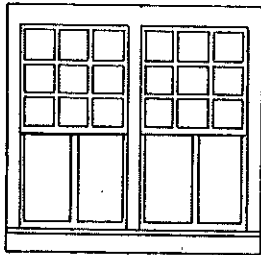

Double Hung Double Window
68" x 78", 11 Pane
#4045

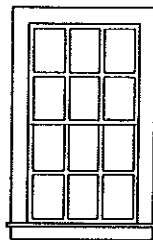

Double Hung Window
36" x 64", 12 Pane
#4028

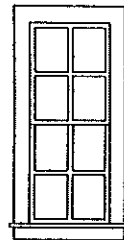

Double Hung Window
27" x 64", 8 Pane
#4029

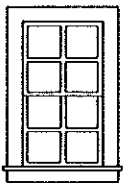

Double Hung Window
27" x 38", 8 Pane
#4027

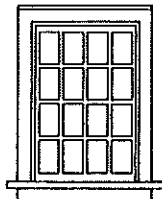

Double Hung Window
36" x 56", 16 Pane
#4026

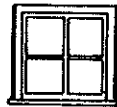

Single Sash
28" x 28", 4 Pane
#4047

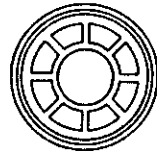

Rnd Masonry Window
48" dia.
#4063

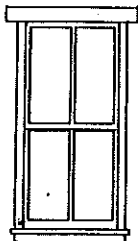

Double Hung Window
39" x 69", 4 Pane
#4056

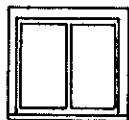

Single Sash
34" x 32", 2 Pane
#4046

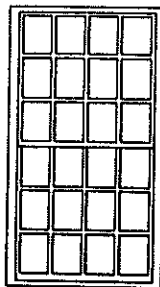

Masonry Window
48" x 96"
#4058

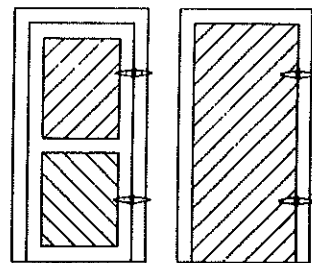

Shed Door
Diagonal Sheathed
#4030



Ice Hatches, Hardware
30' Refrigerator Car
D&RGW
#4015

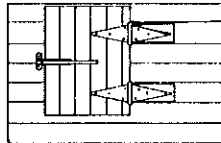

Ice Hatches, Hardware
Standard Gauge Refrigerator Car
#4016

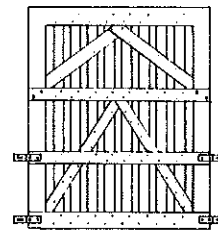

Stock Car Door
D&RGW
#4004

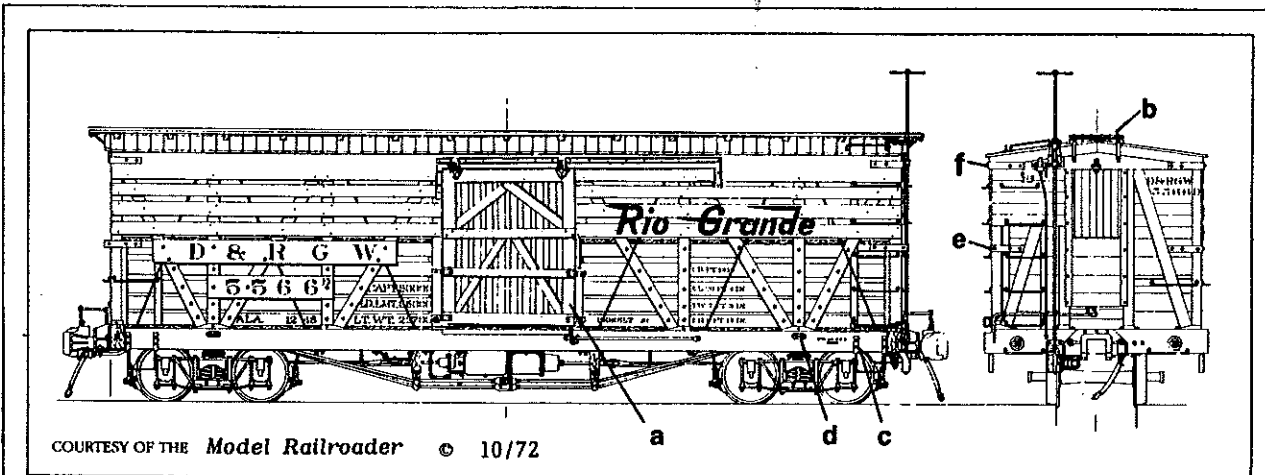

COURTESY OF THE Model Railroader © 10/72

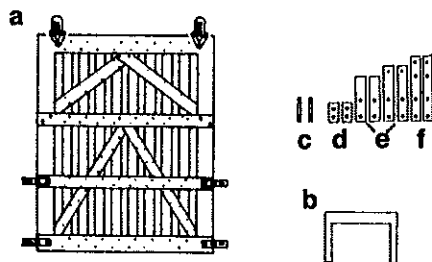

Stock Car Door, End Detail
D&RGW
#4005

Refrigerator Car Door Hardware
Standard and Narrow Gauge
#4014

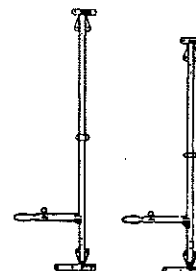

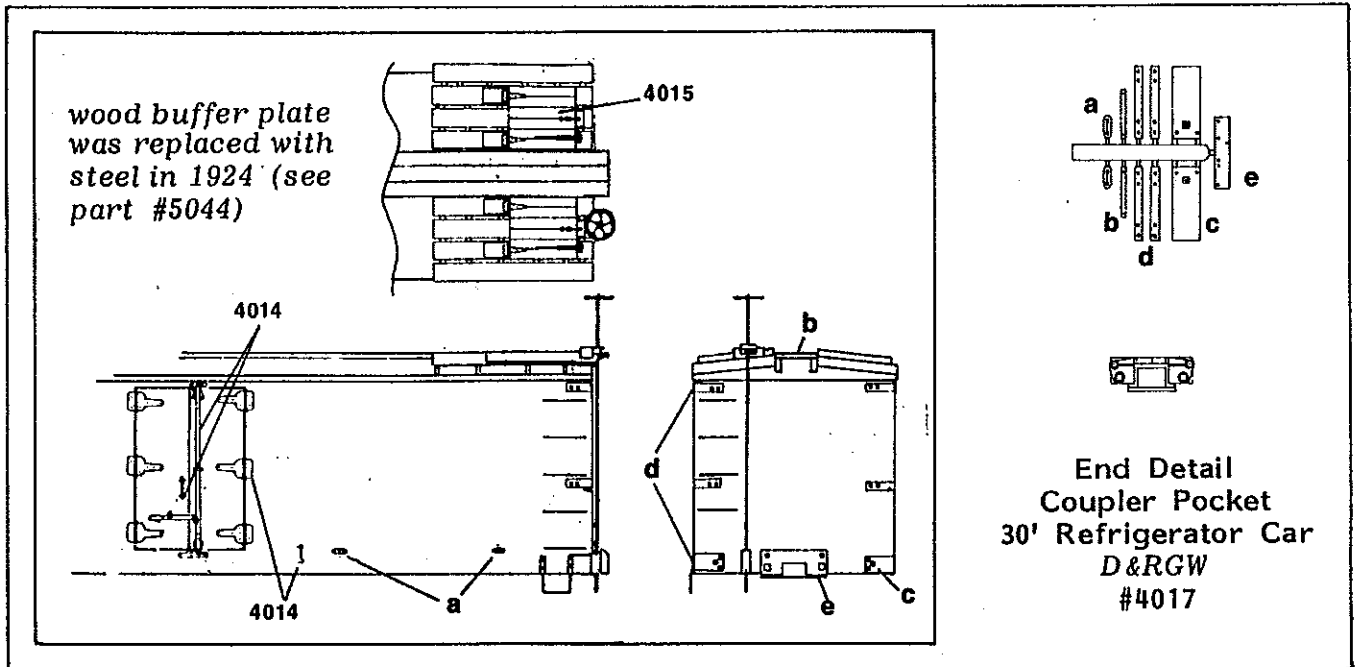
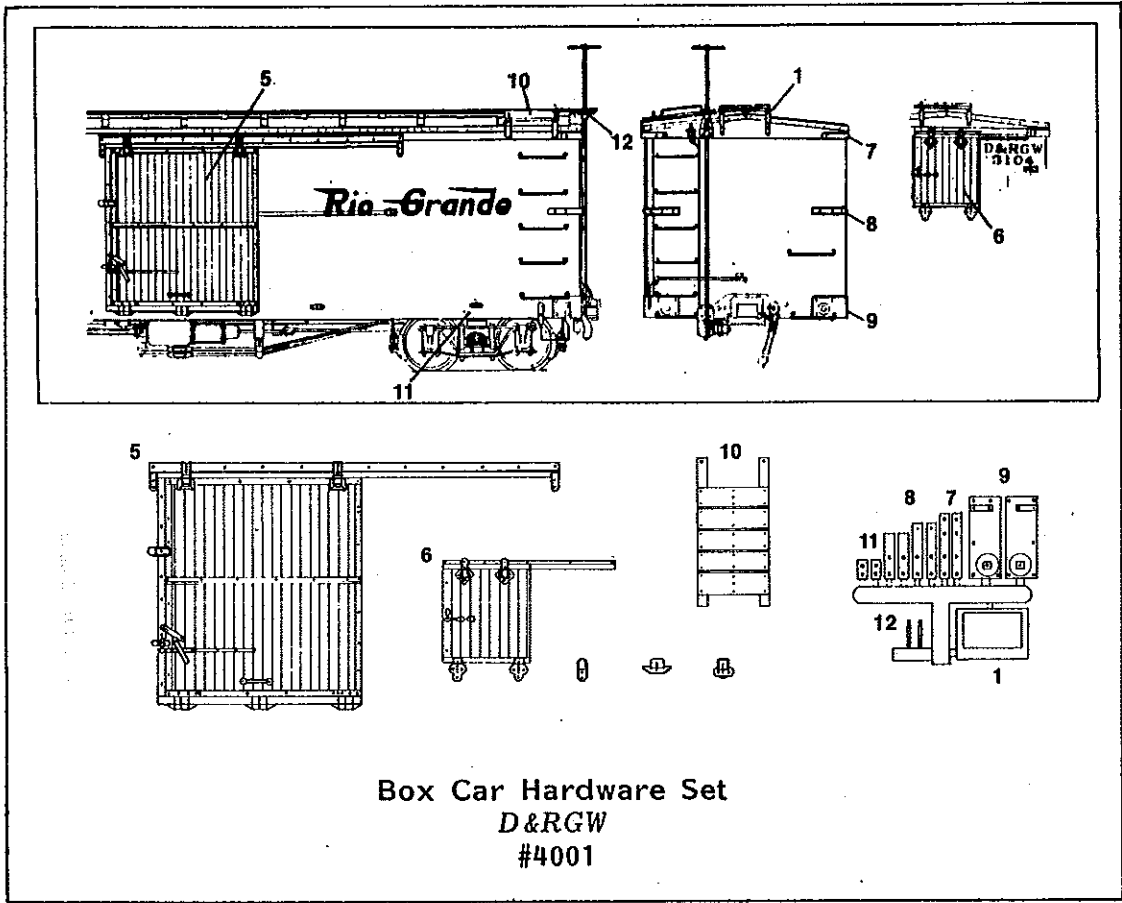

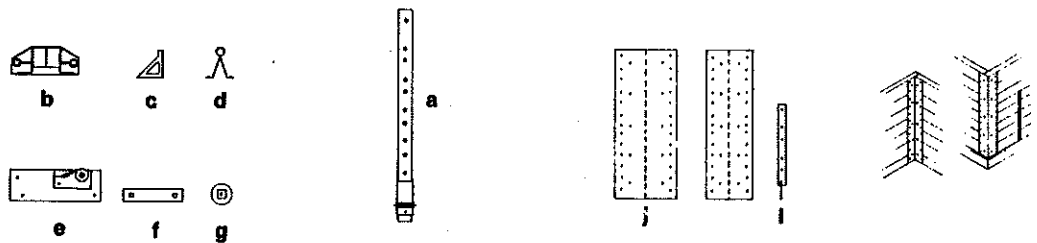
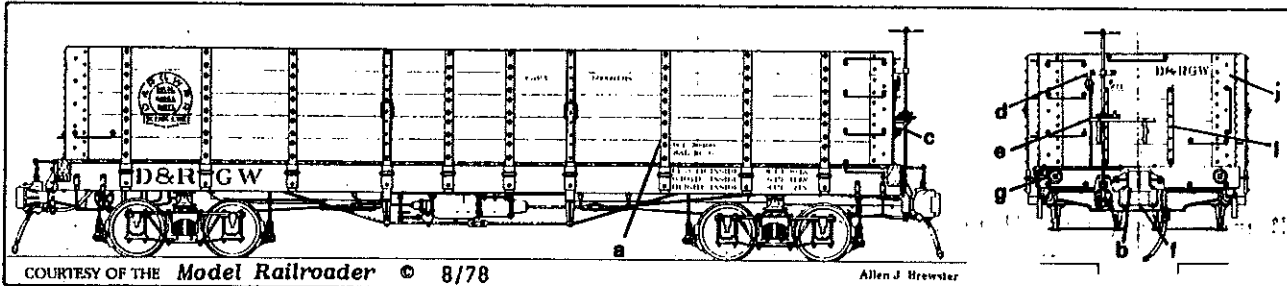

High Side Gondola Hardware Set
D&R GW
#4012

Westinghouse AB Brake Set
w/ Ajax Handbrake
#4057

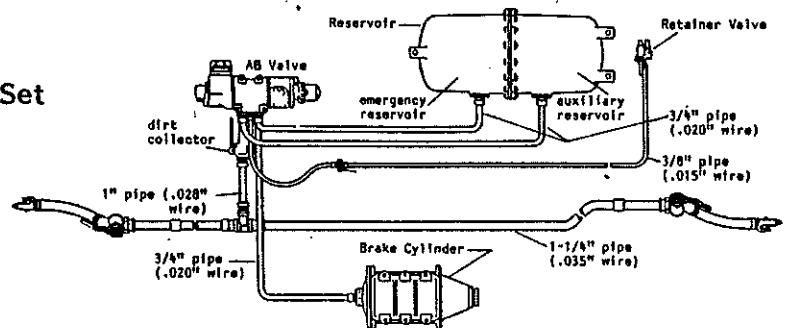

Piping Diagram

- Set Includes:
- Brake Wheel
 - AB Brake Valve
 - Brake Cylinder
 - Reservoir
 - Bell Crank
 - Ajax Brake Gear Housing
 - Cylinder Mounting Bracket
 - Reservoir Mounting Bracket
 - Brake Levers
 - Retainer Valve
 - Dirt Collector
 - Brake Rods
 - Chain

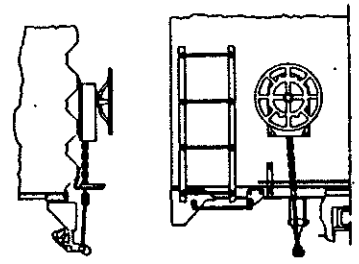

Typical Application c. 1980

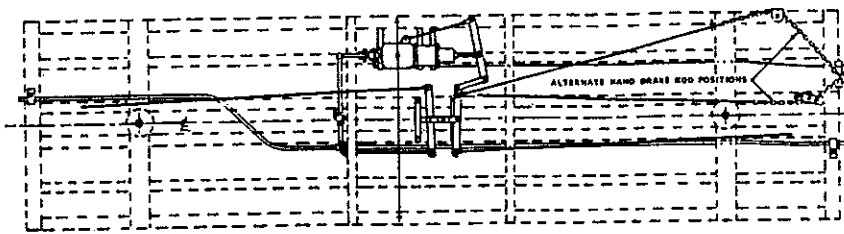

NY Air Brake Set, Type K, 8" x 8"
#4064

Set includes: Misc. pipe fittings, air hoses; clevises, brake chain; brake staff brackets, fittings; brake wheel; retainer valve, cylinder release valve, push rod; brake levers; NY brake cylinder, mounting brackets

On the C&S, this brake system was used on the truss rod cars with archbar trucks, built for and by the C&S. (ie. Gons, Box Cars, Stock Cars, Caboose).

A similar system was used on most F&CC Box Cars. These cars were subsequently sold to other railroads. In many cases, the brake system was maintained (ie. SP NC, Montana Southern, Pacific Coast RR, Magma, and N-C-O).



6 spoke brake wheel
C&S SP
#4059



Ajax Brake Wheel
#4062



C&S BETTENDORF
4" 6" WB
#4065

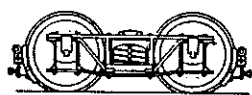

Archbar Truck
3'7" Wheelbase
D&RGW
Brown Delrin, #4022
Black Delrin, #4023



Griffin Denver 26" Wheelsets
Ribbed Back
Metal Rims, Axles
36" Gauge
#4013

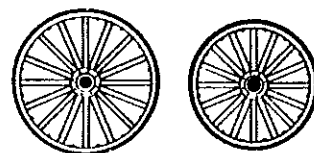

Light Wagon Wheels
44" and 48"
#4010



3" Queenposts
D&RGW
#4031
in brass, 4043

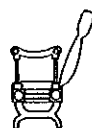

Standard Gauge Coach Seats
2 Wood Ends
#4006

Narrow Gauge Coach Seats
1 Wood End
#4007



Locomotive Bell
15 1/2" Diameter
#4011

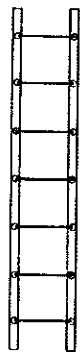

Freight Car Ladders
7 Rung
#4020



Stake Pocket
Single U-Bolt
#4008



Turnbuckles
D&RGW
#4019
in brass, 4042



Stake Pockets
2 U-Bolts
D&RGW
#4021



Freight Car Stirrup Steps
D&RGW
#4018
in black Delrin



D&RGW Box Car Coupler Pocket
In #4048 1027

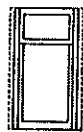

Passenger Car
Window
#4049

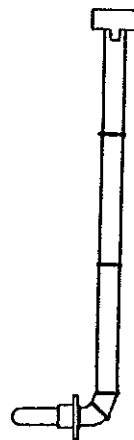

Smoke Jack
#4060

GRANDT LINE PRODUCTS

1040 B SHARY CT CONCORD, CA 94518
(510) 671-0143 fax 671-0806

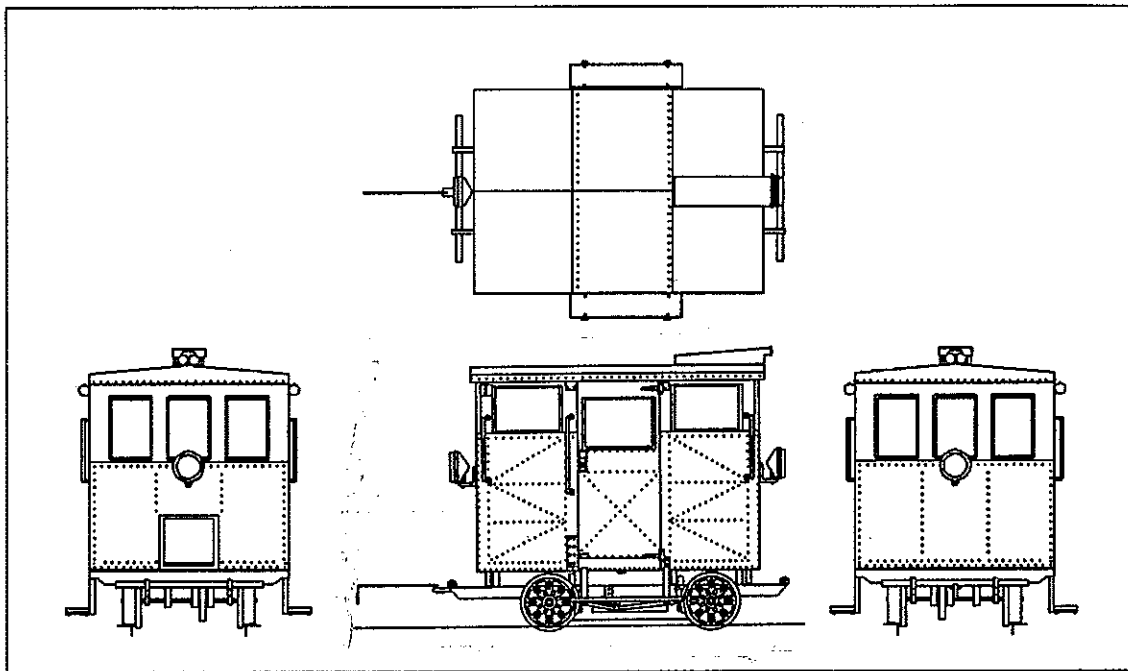

IN On3...

THE RGS COVERED SPEEDER

MOTORIZED KIT # 97064

AVAILABLE NOW AT \$38.50 PLUS \$4.95 SHIPPING

COMPLETE STYRENE KIT INCLUDES MABUCHI 40:1 MOTOR

BASED ON FAIRMONT A-3 EXTRA GANG CAR

"WINTERIZED" c. 1940 IN THE RGS SHOPS

SIMILAR TO GANG CARS USED THROUGHOUT THE U.S. DURING THE 40'S.

GRANDT LINE PRODUCTS

1040 B SHARY CT CONCORD, CA 94518
(510) 671-0143

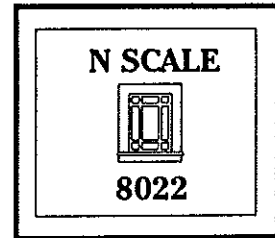
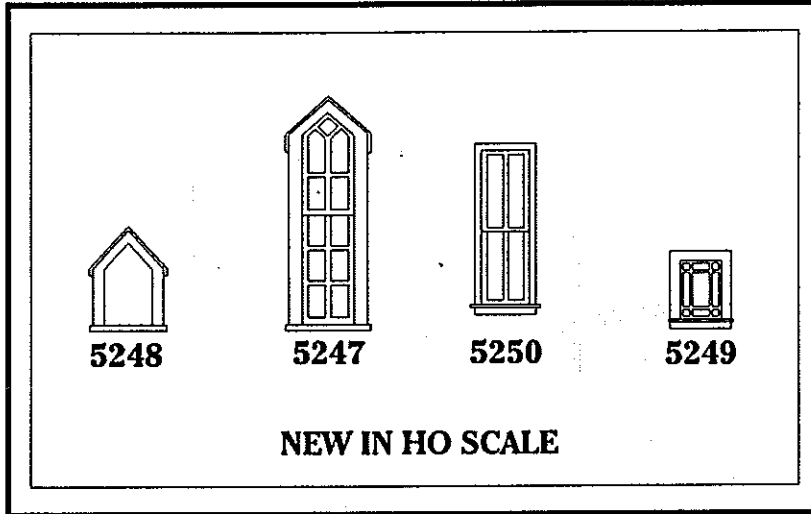

#8022
PICTURE WINDOW

- #5247 PEAKED TOP DOUBLE HUNG CHURCH WINDOW
- #5248 PEAKED TOP ATTIC WINDOW
- #5249 VICTORIAN ATTIC/CLOSET WINDOW
- #5250 4-PANE DOUBLE HUNG WINDOW

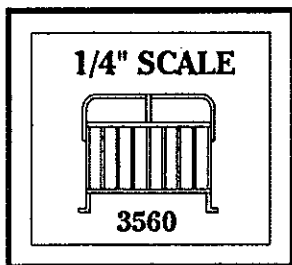

#3560
IRON BEDFRAME

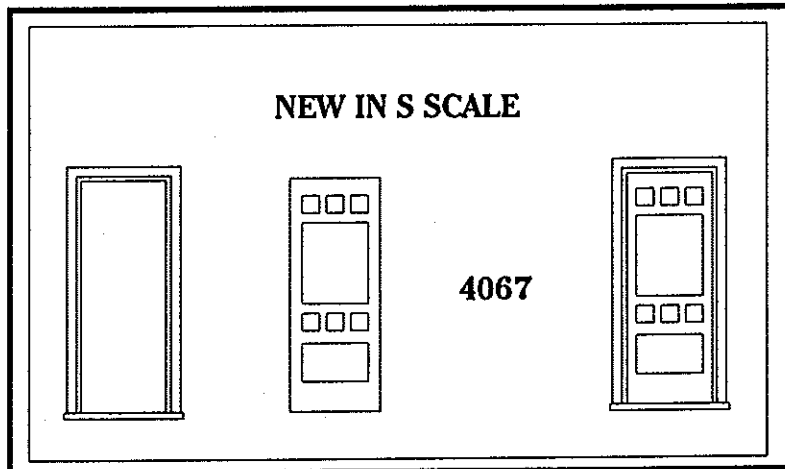

#4067
RESIDENCE DOOR
WITH SINGLE WINDOW

GRANDT LINE PRODUCTS

1040 B SHARY CT CONCORD, CA 94518
(510) 671-0143

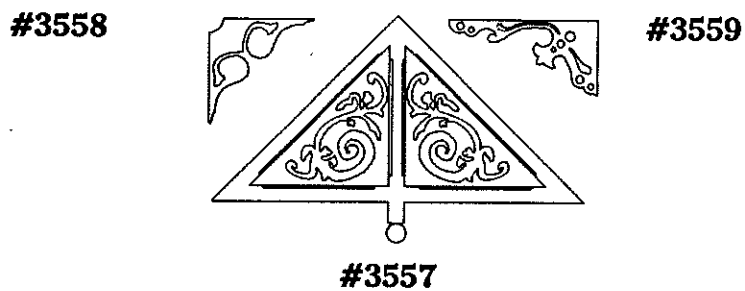
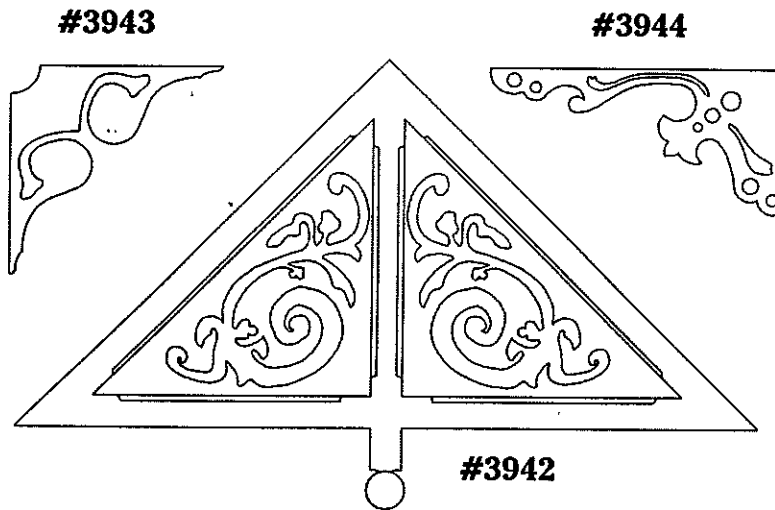

NEW STRUCTURAL DETAILS IN 1/4" AND 1/2" SCALES

- #3932 GABLE TRIM (1/2" scale)
- #3943 EAVE TRIM (1/2" scale)
- #3944 PORCH TRIM (1/2" scale)
- #3557 GABLE TRIM (1/4" scale)
- #3558 EAVE TRIM (1/4" scale)
- #3559 PORCH TRIM (1/4" scale)

RROBB NARROW GAUGE PICTORIAL SERIES

81

SOFTBOUND REFERENCE BOOKS FOR THE DISCRIMINATING MODELLER

NARROW GAUGE PICTORIAL, VOL. I
Rio Grande Southern and D&RGW Motive Power

NARROW GAUGE PICTORIAL, VOL. II
Passenger Cars and Trains of the D&RGW

NARROW GAUGE PICTORIAL, VOL. III
Box Cars, Flat Cars and Gondolas of the D&RGW

NARROW GAUGE PICTORIAL, VOL. IV
Stock Cars, Refrigerator Cars, and Tank Cars of the D&RGW

NARROW GAUGE PICTORIAL, VOL. V
Caboose of the D&RGW

NARROW GAUGE PICTORIAL, VOL. VI
Motive Power of the Colorado & Southern

NARROW GAUGE PICTORIAL, VOL. VII
Denver and Rio Grande Western Work Equipment--OA to OZ

NARROW GAUGE PICTORIAL, VOL. VIII
Colorado & Southern Freight and Passenger Cars

NARROW GAUGE PICTORIAL

Passenger Cars and Trains of the D&RGW

VOLUME II

OVER 190 PAGES OF PHOTOS

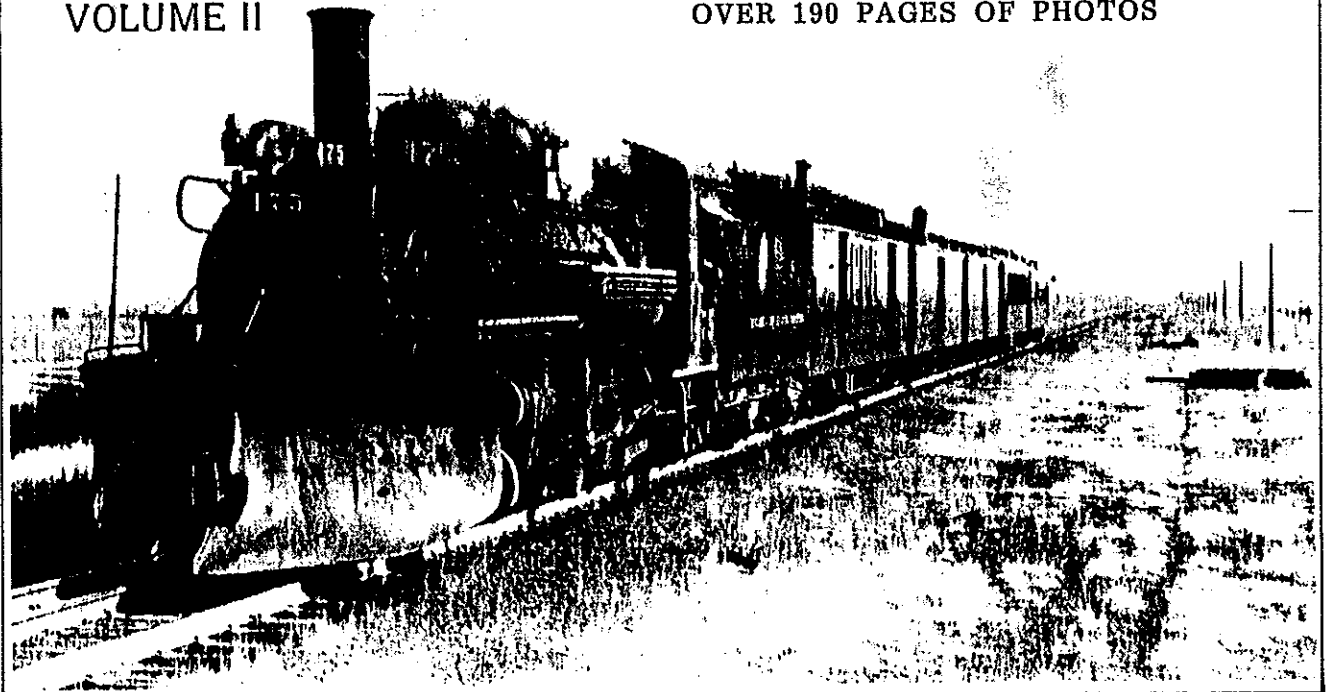



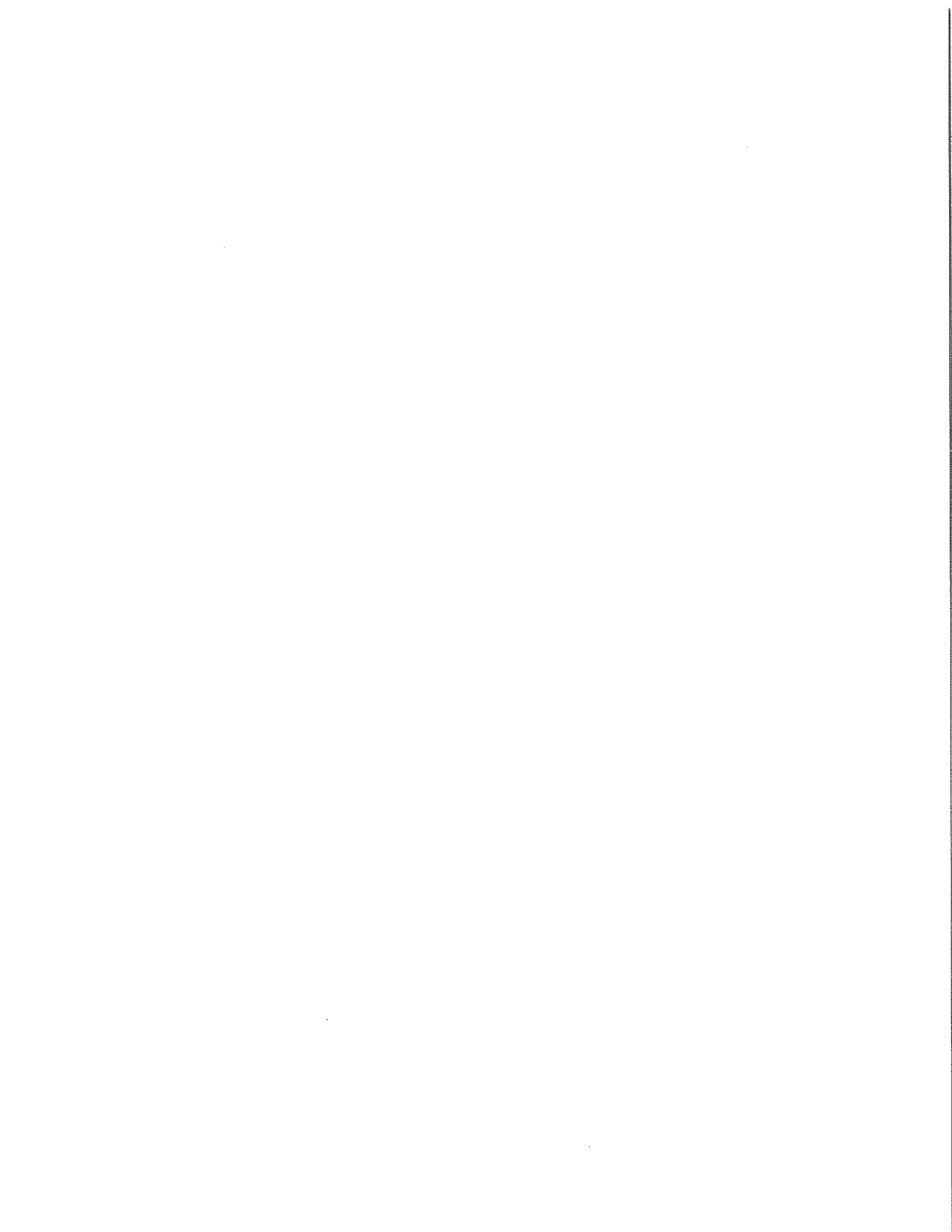

GRANDT LINE

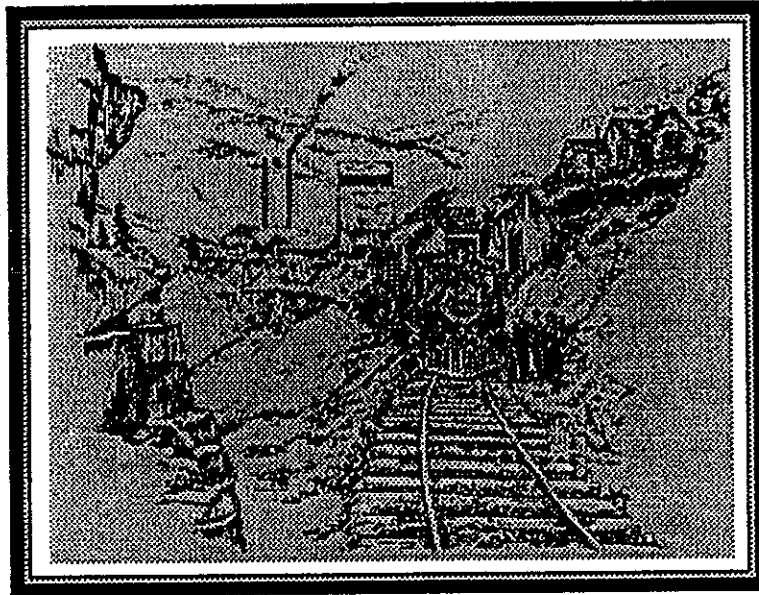

PRICE LIST JANUARY, 1995

FOR MORE INFORMATION, SEE OUR ILLUSTRATED CATALOGS

HO/N SCALES \$4.25

O/S SCALES \$6.00

MINIATURES \$4.75

GRANDT LINE PRODUCTS, INC.

1040 B SHARY COURT CONCORD, CA 94518
(510) 671-0143 FAX 671-0806

PRICES SUBJECT TO CHANGE WITHOUT NOTICE

CAR COMPONENTS, MISCELLANEOUS HARDWARE

1	1 1/4" NUT,BOLT,WASHER	170 EA	1.95	52	C&S CABOOSE WINDOW AND DOOR SET	SET	1.95
2	D&RGW BOX CAR END DETAIL SET	1 SET	1.95	53	D&RGW STAKE POCKETS-2 U-BOLTS	24	1.95
3	D&RGW HI SIDE GON CORNER PLATES	4 SET	1.95	54	D&RGW SCALE TURNBUCKLES-CORED FOR .025" WIRE	24	1.65
4	D&RGW HI SIDE GON STAKES	40 EA	1.95	55	GRIFFIN DENVER 24" WHEELSETS-36" GAUGE-METAL RIMS	4 AXLE	6.35
5	BOX CAR DOOR LATCHES	3 SET	1.65	56	GRIFFIN DENVER 24" PILOT WHEELSET 36" GAUGE-METAL RIMS	1 AXLE	2.75
6	BOX CAR DOOR HANGERS/STOPS ASST	2 SET	1.65	57	GRIFFIN DENVER 20" WHEELSETS 24" GAUGE-METAL RIMS	4 AXLE	6.35
7	SP LOW WALL GONDOLA STAKES	10 EA	2.20	58	GRIFFIN BOSTON 20" WHEELSETS 36" GAUGE-METAL RIMS	4 AXLE	6.35
8	1 1/4" NUT,BOLT	175 EA	1.95	59	D&RGW 30' REEFER COUPLER POCKETS	4	1.95
9	1" SQUARE NUT,BOLT	175 EA	1.95	60	D&RGW CABOOSE GRAB IRON ENDS AND MARKER BRACKET	3	1.95
10	D&RGW REEFER CAR DOOR HARDWARE	2 SET	1.65	61	SPNG CAR DETAILS	2	1.65
11	72" TANK CAR ENDS	2 EA	1.65	62	7/8" SQ NUT,BOLT,WASHER	175	1.95
12	77" TANK CAR ENDS	2 EA	1.65	63	1/2" SQ NUT,BOLT,WASHER	175	1.95
13	STOCK CAR DOORS	2 EA	1.65	64	D&RGW SHRT CABOOSE/REEFER BOLSTER	4	1.95
14	D&RGW REEFER DOOR ICE HATCHES AND PLATFORMS	SET	3.85	65	B&SR 4 RUNG LADDERS-DEL RIN	4	2.20
15	1 1/4" HEX NUT,BOLT	175 EA	1.95	66	D&RGW DROP BOTTOM GON COUPLER PKT	2	1.40
16	2 1/2" NUT,BOLT,WASHER	50 EA	1.95	67	6" QUEENPOSTS	24	1.95
17	60" STAKES IN POCKETS	10	1.65	68	5" QUEENPOSTS	24	1.95
18	2 1/2" NUT ON RECTANGULAR WASHER	20	1.65	69	3" QUEENPOSTS	24	1.95
20	2 1/2" NUT ON ELLIPTICAL WASHER	40	1.65	70	10" QUEENPOSTS	24	1.95
21	D&RGW CABOOSE SIDE WINDOWS	8	1.95	71	D&RGW SHORT REEFER END DETAIL	2 SETS	1.65
22	DUMMY TOWER COUPLERS	6	2.20	72	GILPIN TRAM LINK AND PIN COUPLER	6	1.95
23	1 1/2" NUT,BOLT,WASHER	100	1.95	73	STAKE POCKET-SINGLE U-BOLT	24	1.95
25	INSIDE HUNG OUTFIT CAR WDW-4 PANE	4	1.95	74	D&RGW BOX CAR BOLSTERS	4	1.95
26	SLIDING OUTFIT CAR WDW-8 PANE	4	1.95	75	TOWER SEMI-AUTOMATIC COUPLERS	4	1.95
27	D&RGW BOX CAR COUPLER POCKET	4	1.95	78	CABOOSE BUNK CUSHIONS	2	1.65
28	D&RGW BOX CAR DOOR RUNNERS	5	1.95	80	2 1/2" SQ NUT ON 6" SQ WASHER	50	1.95
29	D&RGW BRAKE SHOES & BEAMS	1 SET	1.65	81	2 1/2" HEX NUT ON 6" SQ WASHER	50	1.95
30	CIRCUS WAGON WHEELS-PLAIN	SET	1.95	82	2 1/2" SQ NUT-NO WASHER	50	1.95
31	CIRCUS WAGON WHEELS-SUNBURST	SET	1.95	83	FREIGHT CAR STIRRUP STEPS BLACK DELRIN	20	1.95
32	POPCORN WAGON WHEELS	SET	1.95	84	D&RGW CABOOSE BRAKE LEVERS	3 SETS	1.65
33	14" BRAKE WHL-6 SPOKE-RATCH/PAWL	4	1.95	85			
34	CAST IRON RAILCAR WHEELS-18"9 SPOKE	4	1.95	86			
35	SAME-8 SPOKE	4	1.95	87			
36	SAME-20"-8 SPOKE	4	1.95	88	C&S SP 6 SPOKE BRAKE WHEEL	4	1.95
37	SAME-20"-9 SPOKE	4	1.95	89	STAKE POCKETS-SINGLE U-BOLT	24	1.95
38	SAME-20"-10 SPOKE	4	1.95	90	FREIGHT CAR STIRRUP STEPS-BROWN DELRIN	20	1.95
39	SHEFFIELD 20" PRESSED STEEL RAILCAR WHEELS	4	1.95	91			
40	FAIRMONT 16" PRESSED STEEL RAILCAR WHEELS	4	1.95	92			
41	SR&RL RAILCAR PEDESTALS /SPRINGS	8	2.20	93	1 1/4" NUT,3" MALLEABLE WASHER	100	1.95
42	WESTSIDE LUMBER CO. PUSHCAR AND MODEL T SPEEDER WHEELS S SPOKE AND DRIVE CHAIN	4	2.50	94	LOVSTED 15" BRAKE WHEEL-WESTSIDE LUMBER CO.	4	1.95
43	D&RGW 16" BRAKE WHEEL W/RATCH/PAWL	4	1.95	95	D&RGW STOCK CAR POST AND BRACE FEET	2 SET	1.65
44	2 1/8" SQ NUT,5" RIBBED WASHER	10	1.95	96	PILOT WHEELSET-24"-9 SPOKE-36" GA.	1 AXLE	2.75
45	GRIFFIN DENVER 26" WHEELSETS-SCALE AXLES-36" GAUGE-ALL PLASTIC FOR SCENERY	4 SETS	2.75	97	TYPE K WESTINGHOUSE BRAKE CYL-8X12	1	1.10
47	D&RGW GONDOLA BRAKE LEVERS AND CLEAVISES	4	1.65	98	1 1/4" NUT,2" STEEL WSHR,3/4" BOLT	100	1.95
48	WATER TANK HOOP FASTENERS	96	3.00	99	1 5/8" NUT,2 1/2" STEEL WASHER, 1" BOLT	100	1.95
49	D&RGW SHORT CABOOSE CUPOLA WDWs	4 SETS	1.95	100	7/8" NUT,1 3/8" STEEL WASHER 1/2" BOLT	100	1.95
50	D&RGW CABOOSE DOORS	4	1.95				
51	D&RGW OLD TIME 15" SPOKE BRAKE WHL	4	1.95				

CAR COMPONENTS, MISCELLANEOUS HARDWARE

101	1 1/16" NUT, 1 3/4" STEEL WASHERS, 5/8" BOLT	100	1.95	142	DUMMY CHAIN AND SPROCKETS	4	1.65
102	POST AND BRACE TIE-ROD PLATES FOR BOX, FLAT, STOCK CARS	2 SET	1.65	143	STOVEPIPE W/BONNET AND THIMBLE	2	1.65
103	D&RGW STOCK CAR BOLSTER-30' CAR	4	1.95	144	ROOFWALK SUPPORTS FOR NG CARS WITH MURPHY ROOFS	42	1.95
104	D&RGW STOCK CAR CORNER STRAPS AND END DOOR GUIDES	SET	1.95	145	SAME-FOR CARS W/O MURPHY ROOFS	42	1.95
105	11 1/2" DIAMETER LOCOMOTIVE BELL	1	1.40	146	CENTRIFUGAL DIRT COLLECTOR, DUPLEX RETAINER VALVE	2	1.65
106	REG-RADIATOR FOR RAIL CARS, ETC	1	1.40	147	LINK AND PIN COUPLERS-DELTRIN	4	1.85
107	D&RGW BOX CAR END ROOF WALKS	4	1.50	148	GRAB IRON BENDING FIXTURE	1	1.10
108	LIFT RING AND EYEBOLT ASSORTMENT	108 ASST	1.95	149	MARKER LAMPS	2	1.65
109	D&RGW HI SIDE GON COUPLER POCKET AND END DETAIL	2	1.50	150	TAIL LIGHT AND DRUM HEADLIGHT FOR RGS GOOSE #6 (C.1934-46) ETC.		1.65
110	COAL LOAD FOR 13 TON SHAY	1	3.85	151	PORTER TENDER PEDESTALS, JOURNAL BOXES, SPRINGS	1 SET	6.05
111	D&RGW BRAKE STAFF BRACKETS- MISC. FITTINGS	2 SET	1.65	152	RIVETS-.032" DIA. CONICAL HEAD	150	1.95
112	MISC. PIPE FITTINGS AND AIR HOSES	2	1.65	153	RIVETS-.032" DIA. ROUND HEAD	150	1.95
113	COUPLER LIFT BARS AND BRACKETS	3	1.95	154	RIVETS-.043" DIA. ROUND HEAD	150	1.95
114	CLEVIS, CHAIN, BRAKE LEVER	1 SET	1.50	155	RIVETS-.043" DIA. CONICAL HEAD	150	1.95
115	AIR HOSES AND ANGLE COCKS-DELTRIN	4	1.65	156	RIVETS-.063" DIA. ROUND HEAD	100	1.95
117	BACKHEAD FOR SMALL LOCO	1	1.40	157	RIVETS-.063" DIA. CONICAL HEAD	100	1.95
118	BOLSTER-CAST STEEL MODIFIED STD. GAUGE FOR HI SIDE GON	4	1.95	158	8 TON PORTER LINK AND PIN COUPLERS	4	1.85
119	D&RGW HI SIDE GON NEEDLEBEAM AND QUEENPOST SUB-ASSEMBLY	4	1.95	159	PORTER OR SMALL LOCO PILOT (COWCATCHER)	1	1.65
120	D&RGW HI SIDE GON ECONOMY DRAFT GEAR AND BOLSTER SET	1 SET	6.60	160	AJAX BRAKE WHEEL-DELTRIN	3	2.20
121	D&RGW HI SIDE GON SIDE STAKE EXTENSION	24	1.95	161	TAPERED STACK-TOP MOUNTING HEADLIGHT BRACKET & EXTENDED SMOKE BOX-CAN BE USED ON 8 TON PORTER	SET	3.85
122	D&RGW HI SIDE GON LEVERS, FULCRUM AND LEVER GUIDES	4 SET	1.95	162	WING NUT ASSORTMENT	3	1.95
123	1890 PORTER BUILDERS PLATES	4	1.65	BRASS PARTS...1/4" SCALE			
124	18" OIL BURNING HEADLIGHT	1	1.65	81001...			
125	1906 PORTER BUILDERS PLATES	2	1.65	81001	1 1/4" NBW	34	5.35
126	NUMBER PLATE ASSORTMENT #1-8	8	1.65	81008	1 1/4" NUTS, BOLTS	35	5.35
127	1 1/2" HEX NUT, BOLT-NO WASHER	100	1.95	81009	1" NUTS, BOLTS	35	5.35
128	DISCONTINUED			81015	1 1/4" HEX NUTS, BOLTS	34	5.35
129	C&S/RGS HAND BRAKE FITTINGS W/BRAKE WHEEL, SIDE CHAIN, ROLLER, CHAIN	SET	1.95	81016	2 1/2" NBW	10	5.35
130	CAB DETAIL-1 QT PUMP OILER-3 PINT VALVE OIL CAN	2 EACH	1.65	81018	2 1/2" NUTS ON RECTANGULAR WASHERS	10	5.35
131	14" WHEELSETS-3' GAUGE	4 AXLE	6.05	81020	2 1/2" NUTS ON ELLIPTICAL WASHERS	20	3.00
132	SAME-2' GAUGE	4 AXLE	6.05	81023	1 1/2" NUT, BOLT, WASHER	20	5.35
133	18" WHEELSETS-3' GAUGE	4 AXLE	6.05	81027	D&RGW COUPLER POCKET	2	9.90
134	18" WHEELSETS-2' GAUGE	4 AXLE	6.05	81033	14" BRAKE WHEEL-6 SPOKE	2	10.45
135	CAST IRON GALLOPING GOOSE PILOT WHEELS-16"	4	1.95	81034	CAST IRON RAILCAR WHEELS-18" 9 SPOKE	4	18.70
136	3" QUEENPOSTS-D&RGW BOX, STOCK, CAB.	24	1.65	81035	SAME-18"-8 SPOKE	4	18.70
137	BRAKE CYLINDER RELEASE VALVE AND PUSH ROD-DELTRIN	2	1.65	81036	20"-8 SPOKE	4	18.70
138	8X8 NY AIR BRAKE SET-TYPE K FOR C&S/RGS TRUSS ROD CARS WITH ARCHBAR TRUCKS	1 SET	6.05	81037	SAME-20"-9 SPOKE	4	18.70
139	1 1/2" NUT W/4" CAST IRON WASHER- CORED FOR .020" WIRE	80	1.95	81038	SAME-20"-10 SPOKE	4	18.70
140	D&RGW 3000 SERIES NG OBL SHEATHED CAMEL SIDE AND END DOOR SET	1 SET	6.60	81039	SHEFFIELD 20" PRESSED STEEL RAILCAR WHEELS	4	18.70
141	C&S CABOOSE PEDESTALS, JOURNAL BOXES SPRINGS	1 SET	4.95	81040	FAIRMONT 16" PRESSED STEEL RAILCAR WHEELS	4	18.70
				81042	WESTSIDE LUMBER CO. MODEL T SPEEDER WHEELS-"S" SPOKED-20"	4	18.70
				81043	D&RGW 16" BRAKE WHEEL-5 SPOKE	2	10.45
				81051	D&RGW 15" OLD TIME BRAKE WHEEL	1	5.35

CAR COMPONENTS, MISCELLANEOUS HARDWARE, KITS

81053	D&RGW STAKE POCKETS-2 U-BOLTS	12	9.90
81054	D&RGW SCALE TURNBUCKLES	16	9.90
81059	30' REEFER CAR COUPLER POCKET	2	9.90
81060	D&RGW CABOOSE GRAB IRON ENDS AND MARKER BRACKET	1 SET	5.35
81062	7/8" SQUARE NUT,BOLT,WASHER	35	5.35
81063	1/2" SQUARE NUT,BOLT,WASHER	35	5.35
81064	D&RGW SHORT CABOOSE/REEFER BOLSTER	2	11.00
81066	D&RGW DBG COUPLER POCKET	2	9.90
81067	6" QUEENPOSTS	6	5.35
81068	5" QUEENPOSTS	6	5.35
81069	3" QUEENPOSTS	6	5.35
81070	10" QUEENPOSTS	6	5.35
81072	GILPIN TRAM LINK AND PIN COUPLER	2	6.60
81074	D&RGW BOX CAR BOLSTER	2	11.00
81080	2 1/2" NUT,6" SQ WASHER	10	5.35
81081	2 1/2" HEX NUT,6" SQUARE WASHER	10	5.35
81082	2 1/2" NUTS,NO WASHER	20	5.35
81084	LAMP REFLECTORS AND BULBS	4	6.35
81088	BRAKE WHEEL-6 SPOKE	2	10.45
81089	STAKE POCKETS-SINGLE U-BOLT	12	9.90
81090	FREIGHT CAR STIRRUP STEPS	5	5.75
81093	1 1/4" NUT,3" MALLEABLE WASHER	20	5.35
81094	LOVSTED 15" BRAKE WHEEL	2	10.45
81098	1 1/4" NUT,2" STEEL WASHER	35	5.35
81099	1 5/8",2 1/2" STEEL WASHERS	20	5.35
81100	7/8" NUT,1 3/8" STEEL WASHER, 1/2" BOLT	35	5.35
81101	1 1/16" NUT,1 3/4" WASHER,5/8" BOLT	34	5.35
81103	D&RGW STOCK CAR BOLSTER-30' CAR	2	11.00
81105	LOCOMOTIVE BELL-11 1/2" DIAMETER	1	5.75
81106	REO RADIATOR	1	5.75
81108	EYEBOLT AND LIFTRING ASSORTMENT	1 SET	5.35
81110	DUMMY CHAIN AND SPROCKET FOR #81042	1	5.35
81111	BRAKE STAFF FITTINGS-RATCHET&PAWL	1	5.35
81112	PIPE FITTING CLUSTER/AIR HOSES	1 SET	5.35
81113	COUPLER LIFT BAR/BACKET	1 SET	5.35
81114	CLEVISES/BRAKE LEVERS	1 SET	5.35
81115	AIR HOSES/ANGLE COCK		5.35
81122	D&RGW HI SIDE GON LEVERS FULCRUM,GUIDE		5.35
81127	1 1/2" HEX NUTS,BOLTS	25	5.35
81136	3" QUEENPOST-D&RGW	8	5.35
81139	1 1/2" NUT W/4" CAST IRON WASHER- CORED FOR .020" WIRE	20	5.35
81152	RIVETS-.032"DIA. CONICAL HEAD	30	5.35
81153	SAME-ROUND HEAD	30	5.35
81154	SAME-.043" DIA. ROUND HEAD	30	5.35
81155	SAME-CONICAL HEAD	30	5.35
81156	SAME-.063" ROUND HEAD	20	5.35
81157	SAME-CONICAL HEAD	20	5.35
82101	BLW 54" BOILER FRONT	1	6.35
82102	BLW 50' BOILER FRONT	1	6.35
82103	PORTER 37 1/2" BOILER FRONT	1	6.35
82105	D&RGW SHORT CABOOSE LADDER	2	10.20

82106	DSP&P DRIVER CENTERS-MASON BOGIE 37" DIAMETER	6	28.60
82107	C&S MOGUL DRIVER CENTERS-39" DIA	6	28.60
82108	HINKLEY 2' FORNEY DRIVER CTRS-33"	4	19.95
82109	PORTER 24" DRIVER CENTERS	4	19.95
82110	BLW 28" DRIVER CENTERS	4	19.95
82112	MASON BOGIE 42" DRIVER CENTERS	6	28.60
82113	BLW 45"X46" DRIVER CENTERS T-12	6	28.60
82115	BLW 36"(D&RGW C-16)-DRIVER CENTERS	8	33.55
82116	STAKE POCKET-SINGLE U-BOLT-2' CARS	24	9.90
82117	LIMA SHAY BOILER FRONT 30"	1	6.35
82120	CLIMAX BOILER FRONT-42"	1	6.35
82121	RGS #20 DRIVER CENTERS	6	28.60
82123	PORTER LOCO BUILDERS PLATES	2	5.75
82125	HINGE ASSORTMENT	1 SET	6.00
82128	LIMA SHAY BLR FRNT-GILPIN TRAM #2	1	6.00
82129	HARRINGTON SEMAPHORE ORDER BOARD	1	12.40
82130	VALVE HANDLES ASSORTMENT	1 SET	6.60
82131	OIL CAN,THROTTLE LEVER	1 SET	6.00
82132	REVERSE LEVER/OPERATING RODS		6.00
82133	DETROIT LUBRICATOR,MISC.VALVE HNDLS		6.00
82134	INJECTOR,PIPES,MISC. GAUGE	4 SP	22.00
82135	WATER GLASS,LUNKENHEIMER LUBRICATOR VALVES,PIPING		11.00
82136	8&SR 4 RUNG LADDER	1	5.75

1/4" SCALE KITS, TRUCKS,FIGURES—MISC

3001....

3001	D&RGW BOX CAR HARDWARE		9.10
3002	D&RGW HI SIDE GON HARDWARE		5.75
3003	D&RGW NARROW GAUGE PASSENGER CAR SEATS	12 EA	6.35
3006	D&RGW 30' REFRIGERATOR CAR HARDWARE		8.00
3007	D&RGW STOCK CAR HARDWARE		7.15
3008	SP LOW WALL GONDOLA HARDWARE		3.85
3009	D&RGW CABOOSE STOVE WITH STACK	1	1.65
3010	D&RGW PASSENGER CAR STOVE AND STACK	1	1.65
3011	D&RGW COACH OIL LAMP	2	2.75
3012	D&RGW FAIRMONT 36" GAUGE PUSHCAR	1	2.75
3013	55 GALLON DRUMS,FIRE BARREL LIDS, SPIKE CANS	3 SETS	1.95
3014	4 WHEEL BAGGAGE WAGON	1	3.00
3015	DS&P PUSHCAR KIT	1	2.75
3016	COACH SEATS-NARROW GAUGE WOOD ENDS	6	2.75
3017	SAME-STANDARD GAUGE -2 WOOD ENDS	6	3.00
3018	GILPIN TRAM SMALL ORE CAR KIT- LESS TRUCKS		6.90
3020	COAL CHUTE GATE OPERATING MECH.	1	2.75
3021	HEAVY CAST IRON SWITCH STAND	1	2.15
3022	WESTINGHOUSE TYPE K BRAKE CYL. SET	1	5.45
3023	D&RGW 3'7" FREIGHT CAR TRUCKS BROWN DELRIN	1 PR	11.00
3024	18" ROTARY MINE CAR	1	2.20
3027	D&RGW 3'7" FREIGHT CAR TRUCKS BLACK DELRIN	1 PR	11.00

MISCELLANEOUS HARDWARE, KITS, AND CAR COMPONENTS

___ 3028	STATION ORDER BOARD-ROTARY FOR COLORADO GAUGE RR, ETC.	1	2.15	___ 3078	D&RGW 4'8"WB TRUCKS-CAST STEEL FOR FRAMELESS TANK CARS-BLACK DELRIN	1 PR	10.45
___ 3029	C&S-RGS/WP&Y 54" BETTENDORF TRUCKS-BROWN DELRIN	1 PR	10.45	___ 3079	SEE 93079		
___ 3030	CAST METAL FIGURE-SEATED MAN WITH DERBY HAT	1	3.00	___ 3081	SEE 93081		
___ 3031	CAST METAL FIGURE-SEATED MAN WITH FELT HAT-CAN BE USED WITH #3053 KIT	1	3.00	___ 3087	CAST METAL FIG-PLYMOUTH ENGINEER	1	3.00
___ 3034	CAST METAL FIG-VICTORIAN LADY	1	3.00	___ 3088	CAST METAL FIG-LEANING MAN	1	3.00
___ 3036	CAST METAL FIG-"FILLE DE JOIE"	1	3.00	___ 3090	CAST METAL FIG-COUSIN JACK MINER-POSED FOR PUSHING MINE CARS	1	3.00
___ 3038	CAST METAL FIG.-CIGAR STORE INDIAN	1	3.30	___ 3092	SAME-WITH 3024 MINE CAR/TRACK	1	7.65
___ 3040	CAST METAL FIG-ENGINEER FOR PORTER KITS AND SOME OTHER LOCOS	1	3.00	___ 3094	CAST METAL FIG-VICTORIAN MAN WITH TOP HAT	1	3.00
___ 3042	CAST METAL FIG-BARTENDER/STOREKEEPER	1	3.00	___ 3096	CAST METAL FIG-1940'S WALKING LADY	1	3.00
___ 3044	18" GAUGE MINE TRACK	4	2.50	___ 3098	CAST METAL FIG-TRACK WORKER WITH SPADE AND CLAW BAR	1	4.15
___ 3045	18" MINE TRACK CURVE AND SWITCH		2.50	___ 3100	24" GA. KOPPEL 4 WHEEL 3 1/2 YARD GABLE BOTTOM DUMP CAR	2	12.00
___ 3046	CHAMA COAL CHUTE DETAILING SET		16.45	___ 3101	SAME-30" GAUGE	2	12.00
___ 3047	HARRINGTON SEMAPHORE ORDER BOARD	1	2.15	___ 3102	SAME-24" GAUGE	2	12.00
___ 3049	WESTINGHOUSE AB BRAKE SET WITH AJAX HANDBRAKE		5.45	___ 3103	FAIRBANKS-MORSE #37 DUMP CAR-ON3 -DUMPS TO EITHER SIDE		14.25
___ 3050	GILPIN TRAM LARGE ORE CAR LESS TRUCKS		7.15	___ 3104	CAST METAL WATER SPOUT	1 SET	5.50
___ 3051	SEE 93051			___ 3105	SEE 93105		
___ 3052	ONE TON END DUMP COAL CARS	2	6.85	___ 3108	PORTER 0-6-2 TRAILING TRUCK-36"/30"		5.50
___ 3053	STORAGE BATTERY MINE LOCO KIT-UNPOWERED	1	10.20	1/4" SCALE LOCOS AND ROLLING STOCK KITS 93000...			
___ 3054	D&RGW PASSENGER CAR TRUCKS-WOOD BOLSTER	1 PR	13.75	___ 93051	D&RGW DROP BOTTOM GONDOLA	KIT	42.35
___ 3055	SAME--WITH COMPOSITE WOOD AND STEEL OUTSIDE BEARING BOLSTER	1 PR	13.75	___ 93058	BETTENDORF STEEL UNDERFRAME FOR C&S-RGS/WP&Y BOX, STOCK, REEFERS, AND FLAT CARS	KIT	21.95
___ 3056	SAME-WITH CAST STEEL BEARING BOLSTR	1 PR	13.75	___ 93059	C&S STEEL UNDERFRAME STOCK CAR	KIT	40.65
___ 3057	BRAKE SET FOR PASSENGER TRUCKS		4.35	___ 93060	PORTER 18T 0-4-0 SADDLE TANK LOCO	KIT	TEMP DI
___ 3058	SEE 93058			___ 93062	0-4-0 PORTER SQUARE TANK LOCO	KIT	62.65
___ 3059	SEE 93059			___ 93063	0-4-0 PORTER -NO TANKS-W/TENDER	KIT	86.85
___ 3060	SEE 93060			___ 93064	4 WHEEL TENDER	KIT	26.35
___ 3061	18 TON PORTER CAB DETAIL KIT	1 SET	15.35	___ 93065	8T SADDLE TANK PORTER-1899 PERIOD	KIT	69.30
___ 3062	SEE 93062			___ 93066	SAME-30" GAUGE	KIT	69.30
___ 3063	SEE 93063			___ 93067	STEAM DUMMY BODY FOR USE WITH 3065 CHASSIS-ON3	KIT	24.15
___ 3064	SEE 93064			___ 93070	C&S REFRIGERATOR CAR HARDWARE	KIT	26.35
___ 3065	SEE 93065			___ 93071	C&S #1006 4 WHEEL CABOOSE	KIT	40.15
___ 3066	SEE 93066			___ 93072	D&RGW 800 SERIES DROP BOTTOM GON	KIT	42.35
___ 3067	SEE 93067			___ 93079	ULTX FRAMELESS NG TANK CAR-GRAMPS	KIT	TOS
___ 3068	ESTATE CABOOSE STOVE W/COFFEE POT	1	1.65	___ 93081	RGS #6 WORK GOOSE-MICRO-MO POWERED	KIT	185.00
___ 3069	C&S CABOOSE INTERIOR DETAIL KIT	1 SET	10.45	___ 93105	C&S STEEL UNDERFRAME GONDOLA	KIT	38.50
___ 3070	SEE 93070			___ 97052	MABUCHI MOTORED STORAGE BATTERY MINE LOCOMOTIVE KIT-30"	KIT	41.25
___ 3071	SEE 93071			___ 97053	SAME-36"	KIT	41.25
___ 3072	SEE 93072			___ 97058	*NEVADA COUNTY NG #10 PLYMOUTH INDUSTRIAL LOCO-36" GAUGE-POWERED		55.00
___ 3073	ANDREWS TRUCK 56"WB-D&RGW 5900 SERIES STOCK, 150 REEFER, 6400 FLAT BROWN DELRIN	1 PR	11.00	___ 97059	5 TON PLYMOUTH FL1 SWITCHER-ON30" POWERED		49.50
___ 3074	SAME-BLACK DELRIN	1 PR	11.00	___ 97060	*SAME-36" GAUGE		49.50
___ 3075	SR&RL ON2 ARCHBAR TRUCKS WITH NWSL WHEELSETS-BROWN DELRIN	1 PR	8.80	___ 97061	*SAME-24" GAUGE		
___ 3076	D&RGW CABOOSE TRUCKS-3'7"WB BROWN DELRIN	1 PR	11.55	___ 97064	*ON3 RGS ENCLOSED SPEEDER		38.50
___ 3077	D&RGW ARCHBAR TRUCK-4'8"WB-BROWN DELRIN	1 PR	11.00				

NOTE: 24" AND 30" POWERED PORTER KITS ARE AVAILABLE THROUGH SPECIAL ORDER ONLY--PRICE ON REQUEST FOR LOCOS 93060, 93062, 93063

STRUCTURAL COMPONENTS

ARCHITECTURAL COMPONENTS

3501....

___ 3501 WELLS FARGO BALCONY RAILING	6	3.25
___ 3502 WELLS FARGO FRONT DOOR/SHUTTERS	2 SETS	1.95
___ 3503 WELLS FARGO BALCONY DOORS/SHUTTERS	2 SETS	1.95
___ 3504 WELLS FARGO BRICK CORNICE	4 SET	1.95
___ 3505 ORNAMENTAL WOOD PORCH RAIL W/BRKT	5	2.50
___ 3506 BALCONY DOORS/SHUTTERS FOR MASONRY BUILDINGS	3 SETS	4.35
___ 3507 ORNAMENTAL WASHERS,NUTS FOR MASONRY BUILDINGS	1 SET	1.65
___ 3508 HINGE ASSORTMENT	2 SETS	1.65
___ 3509 D&RGW BRICK STATION CHIMNEY	2 SET	1.95
___ 3510 LAMP REFLECTORS	12 EA	1.95
___ 3511 60" DIA. HEAD-FRAME SHEAVE W/BRGS	2 SETS	1.95
___ 3512 ENGINE HOUSE STACK SET	1	5.45
___ 3513 VICTORIAN STOREFRONT DOOR/WDM SET	1	2.20
___ 3514 VICTORIAN PICKET FENCE	3 PCS	1.95
___ 3515 CABLE SHEAVE 24" DIA W/BEARINGS	2 EA	1.65
___ 3516 EAVE AND GABLE BRACE	16 EA	2.20
___ 3517 BAND STAND LATTICE	8 PCS	2.50
___ 3518 END ROOF BRACKETS	6	1.95
___ 3519 SIDE ROOF BRACKETS	8	2.20
___ 3520 OPHIR/DOLORES DEPOT DETAIL SET	1	23.65
___ 3521 RGS STATION GABLE TRIM	3	2.50
___ 3522 RGS STATION EAVE TRIM	4	2.50
___ 3523 RGS STATION ROOF TRIM-12"		3.00
___ 3524 ENGINE HOUSE DOOR HINGES	48 EA	1.95
___ 3525 CABLE SHEAVE/BEARING 34" DIA	2	1.65
___ 3526 UPPER PORCH SPOOL TRIM/BRACKETS	3 PCS	1.95
___ 3527 VICTORIAN TURNED SPINDLE BALLUSTRADE	3 PCS	1.95
___ 3528 TURNED WOOD PORCH POST AND BALL NEWEL POST SET	2	1.95
___ 3529 SHINGLES-TEXTURED PAPER CARD STOCK-APPROX. 70 SQUARE INCHES		4.15
___ 3530 VICTORIAN BRACKETS SET	4	1.95
___ 3531 WIDOWS WALK IRON RAILING	4 PCS	2.75
___ 3532 BUILDING DATE PLAQUES W/NUMBERS	1 SET	1.95
___ 3533 45 DEGREE WOODEN STAIRCASE		3.00
___ 3534 ELECTRICAL METER W/SWITCH BOXES	2 SET	1.65
___ 3535 SAWED BALLUSTRADE	3 PCS	1.95
___ 3536 SQUARE PORCH POST-97" HIGH	4	1.50
___ 3537 SQUARE NEWEL	4	1.50
___ 3538 WINDOW SPACER POST-USED TO COMBINE THE STOREFRONT SERIES	8 EA	1.65
___ 3539 VICTORIAN EAVE BRACKET AND GABLE TRIM-ROOF ANGLE 50 DEGREES		1.95
___ 3540 LOUVRED WINDOW SHUTTERS-13"X48"	8 EA	1.95
___ 3541 SAME-14"X64"	8 EA	1.95
___ 3542 SAME-15"X87"	8 EA	1.95
___ 3543 SAME-17"X64"	8 EA	1.95
___ 3544 SAME-18 1/2"X64"	8 EA	1.95
___ 3545 ORNATE SPOOL AND SPINDLE GABLE TRIM W/BRACKETS	3 SETS	2.50
___ 3546 BRACKET FOR PORCH TRIM	24 EA	1.65

___ 3547 SMOKESTACK SET		2.75
___ 3548 PILASTERS-3'6" X 12" X 3 1/2"	4	1.65
___ 3549 PORCH AND LANAI RAILING	3 PCS	1.95
___ 3550 ARCHITECTURAL DETAIL DENTILS	3 PCS	1.95
___ 3551 SCALLOPED SHINGLES	2 SHTS	4.15
___ 3552 SMOKE JACK	2 EA	1.65
___ 3553 ENGINE HOUSE DOOR HINGES	48 EA	1.95
___ 3554 SPADE AND CLAW BAR-DELTRIN	2 SETS	1.65
___ 3555 "STICK" PORCH RAILING	3 PCS	1.95
___ 3556 TRIM ASSORTMENT GRAB BOX	1 BOX	17.55
___ 3557 GABLE TRIM	2	1.95
___ 3558 EAVE BRACKET	8	1.95
___ 3559 PORCH BRACKET	8	1.95
___ 3560 IRON HEAD/FOOT BOARDS	4	1.95

DOORS

3600....

___ 3601 30" DOOR WITH WINDOW AND FRAME	2	1.95
___ 3602 30" FIVE PANEL DOOR W/FRAME	2	1.95
___ 3603 STATION OR HOUSE DOOR WITH FRAME AND TRANSOM	2	1.95
___ 3604 DURANGO STATION DOOR WITH FRAME AND TRANSOM	2	1.95
___ 3605 RESIDENCE DOOR-OVAL WDW WITH FRAME AND TRANSOM	2	1.95
___ 3606 D&RGW SARGENTS STATION BAGGAGE DOOR-55"X85"	2	1.95
___ 3607 SAME-48"X94"	2	1.95
___ 3608 D&RGW WAITING ROOM DOORS WITH FRAME	2	1.95
___ 3609 ENGINE HOUSE DOOR 5'2"X15'3" W/HNGS	4	4.70
___ 3610 SHED DOORS-DIAGONAL SHEATHED	4	1.95
___ 3611 FREIGHT DOUBLE DOORS 4'9" W/WDW	2	1.95
___ 3612 FACTORY FRONT DOOR 39"X92" WITH TRANSOM FOR MASONRY BUILDINGS	2	1.95
___ 3613 SINGLE DOOR W/FR 4'2"X9'2"	1	1.65
___ 3614 IRON SHUTTERS TO FIT #3613	2	1.65
___ 3615 DOUBLE DOOR W/FRAME 5'5"X9'7"	1	1.65
___ 3616 IRON SHUTTERS TO FIT #3615	2	1.65
___ 3617 OFFICE DOORS W/TRANSOM 36"	2	1.95
___ 3618 FREIGHT DOORS W/TRANSOM-6'X82"	1	1.65
___ 3619 D&RGW STATION DOORS WITH FRAME	2	1.95
___ 3620 RGS STYLE DEPOT DOOR W/WDW AND TRANSOM 36"X84"	2	1.95
___ 3621 RGS STYLE FREIGHT DOOR W/TRANSOM	2	1.95
___ 3622 VICTORIAN RECESSED ENTRYWAY WITH DOUBLE DOORS,TRANSOM,PEDIMENT	KIT	4.70
___ 3623 VICTORIAN FRONT ENTRY DOOR WITH TRANSOM FOR MASONRY BUILDINGS,ETC	1	1.65
___ 3624 COMMERCIAL STOREFRONT DOUBLE DOOR 65"X12' W/TRANSOM-ROUND TOP WOW	1	1.95
___ 3625 SINGLE DOOR 33"X12'	1	1.65
___ 3626 COMMERCIAL STOREFRONT SINGLE DOOR- 33"X12'-DOUBLE TRANSOM-RECT. WDW	1	1.65
___ 3627 SAME-DOUBLE DOOR-65" X 12'	1	1.65
___ 3628 DOOR ASSORTMENT GRAB BOX	1	16.45

WINDOWS, PASSENGER CAR COMPONENTS, RODDING, SHIP GRATING

WINDOWS

3700....

3701	36"x64" DOUBLE HUNG WDW-12 PANE	4	1.95
3702	27"x48" DOUBLE HUNG WDW 8 PANE	4	1.95
3703	27"x64" DOUBLE HUNG WDW 8 PANE	4	1.95
3704	36"x56" DOUBLE HUNG 12 PANE	4	1.95
3705	60"x120" ROUNDHOUSE WDW 40 PANE	3	1.95
3706	30"x69" STATION WDW 4 PANE	3	1.95
3707	36"x56" DOUBLE HUNG WDW 16 PANE	4	1.95
3708	30" RD SILVERTON STATION ATTIC WDW	3	1.95
3709	36"x87" DURANGO STATION WDW 4 PANE	3	1.95
3710	36"x44" DURANGO STATION 2 PANE	3	1.95
3711	31"x56" D&RGW SARGENTS STATION WDW	3	1.95
3712	48"x96" RICO ENG HOUSE WDW 24 PANE	3	1.95
3713	52"x33" HORIZONTAL SLIDING WDW	4	1.95
3714	42"x91" ENG HOUSE WDW 18 PANE	3	1.95
3715	5"x12'6" ROUNDTOP WDW 53 PANE	3	2.50
3716	42" ROUND WINDOW FOR MASONRY BUILDINGS 9 PANE	3	1.95
3717	42"x91" DOUBLE HUNG FACTORY WDW FOR MASONRY BUILDINGS 4 PANE	4	1.95
3718	42"x72" DBL HUNG FACTORY WDW FOR MASONRY BUILDINGS 12 PANE	4	1.95
3719	42"x30" FACTORY WDW FIXED SASH FOR MASONRY BUILDINGS	8	1.95
3720	33"x65" DOUBLE HUNG WDW 4 PANE	4	1.95
3721	36"x70" DOUBLE HUNG WDW 8 PANE	4	1.95
3722	28"x28" ATTIC WDW 4 PANE AND 34"x32" 2.PANE-BOTH SINGLE SASH	4 EA	1.95
3723	36"x82" RGS STYLE DEPOT 2/2 LIGHT	4	1.95
3724	35"x80" RGS STYLE DEPOT 2/2 LIGHT	4	1.95
3725	36"x76" RGS STYLE DEPOT 2/9/LIGHT	4	1.95
3726	24"x44" RGS STYLE DEPOT 1/9/LIGHT	4	1.95
3727	24"x51" RGS STYLE DEPOT 1/9 LIGHT	4	1.95
3728	51.6"x51" DBL RGS STYLE DEPOT 1/9LT	4	1.95
3729	24"x82" 2/2 LIGHT, 24"x82" 4/4 LIGHT RGS STYLE DEPOT	2 SETS	1.95
3730	2'5"x7'6" SLIDING LOWER SASH FOR MASONRY BUILDINGS	4	1.95
3731	VICTORIAN W/TRIANGULAR PEDIMENT 2 PANE	2	1.95
3732	SAME-ARCH TOP PEDIMENT	2	1.95
3733	SAME-FLAT BOX PEDIMENT	2	1.95
3734	64"x12' COMMERCIAL STOREFRONT DBL	2	1.95
3735	33"x12' COMMERCIAL STOREFRONT SNGL	2	1.95
3736	30"x88" DBL HUNG POINTED TOP 4 PANE	2	1.95
3737	63"x36" RECESSED OR SKYLIGHT	2	1.95
3738	100"x36" RECESSED OR SKYLIGHT	2	1.95
3739	48"x72" MASONRY	2	1.95
3740	50"x164" DBL HUNG MASONRY 18 PANE	2	2.20
3741	GRABOX-OVER \$20.00 VALUE		16.45
3742	32"x52" SINGLE, 62"x52" DOUBLE RGS STYLE	2 SETS	1.95
3743	DIAMOND WINDOW AND FRAME	1	1.65
3744	PAIRED ROUNDTOP DOUBLE HUNG 4'6"x6'3"	2	1.95
3745	SINGLE ROUNDTOP 2'X6'	4	1.95

3746	SINGLE AND DOUBLE ROUNDTOP 2/4	2 SETS	1.95
3747	MASONRY DOUBLE HUNG 9/9-104"x37.5"	4	1.95
3748	2 PANE ARCHTOP-DOUBLE HUNG	4	1.95
3749	ROUND MASONRY-36" DIAMETER 9 PANE	2	1.65
3750	2 LIGHT DIVIDED TOP WDW-DIAMOND PATTERNED 40"x74"	4	1.95

1/4" SCALE PASSENGER CAR PARTS

3800....

3801	D&RGW WIDE COACH WINDOWS	12	3.25
3802	D&RGW COACH END DOORS	4	1.95
3803	D&RGW NARROW COACH WINDOWS	10	2.20
3804	D&RGW VESTIBULE DOORS	4	1.95
3805	D&RGW COMBINE BAGGAGE DOOR	2	1.65
3806	D&RGW CLERESTORY WDW/SCREEN	SET	4.15
3807	HALL SCOTT DOUBLE WINDOWS	12	4.15
3808	HALL SCOTT CAR MOTORMAN WDWS	4	1.95
3809	HALL SCOTT OVAL WINDOWS	4	1.95
3810	SCREEN DOOR-D&RGW BUSINESS CAR B-7	2	1.65
3811	SR&RL 2' COACH #20 SET		4.40
3812	SR&RL COMBINE		4.15
3813	SR&RL END DOOR-COMBINE OR BAGGAGE	2	1.65
3814	SR&RL COMBINATION SIDE DOORS	2	1.65
3815	SR&RL/RPO WIDE DOOR	4	1.95
3816	SR&RL 2 NARROW DOORS 4 SIDE WDWS		1.95
3817	PASSENGER CAR CORNER MOLDING	16	1.95
3818	PASSENGER CAR STEPS-21"	4	1.95
3819	PASSENGER CAR STEPS-27"	4	1.95
3820	RPO BAGGAGE CAR STIRRUP STEPS-2/36" AND 4/48"		1.95

MISC

3900....

3901	PLASTIC RODDING-.010"	12 PCS	4.40
3902	PLASTIC RODDING-.020"	12 PCS	4.40
3903	PLASTIC RODDING-.030"	12 PCS	4.40
3904	PLASTIC RODDING-.040"	12 PCS	4.40
3905	PLASTIC RODDING	12 PCS	4.40
3906	SHIP MODEL HATCH GRATINGS-100" SQUARE HOLES	2	1.95
3907	SAME-.050" SQUARE HOLES	2	1.95

CAR COMPONENTS, MISCELLANEOUS HARDWARE, ARCHITECTURAL

1/2" SCALE

3908....

___ 3908 16" BRAKE WHEEL	2	1.95
___ 3909 WOOD SPOKE WHEELS-1/16"BORE-1.3 DIA	4	2.75
___ 3910 SAME-1.5" DIAMETER	4	3.00
___ 3911 .100 HEX NUT ON .250 SQUARE CAST IRON WASHER	24	1.95
___ 3912 SAME-ROUND CAST IRON WASHER	30	1.95
___ 3913 4 PANE WINDOW-FITS OPENING-36"X78"	1	3.30
___ 3914 SHEATHED SINGLE DOOR W/TRANSOM	1	3.00
___ 3915 36"W-SINGLE DOOR W/WDW AND TRANSOM	1	3.30
___ 3916 72"W-DOUBLE DOOR W/WDW AND TRANSOM	1	5.25
___ 3917 72"W-DOUBLE DOOR WITH TRANSOM	1	4.40
___ 3918 41"DIA. ROUND WINDOW-9 PANE	1	2.50
___ 3919 3.125 X 4.38 DIAMOND PATTERNED WDW	1	4.70
___ 3920 FREIGHT CAR STIRRUP STEPS	8 EA	1.95
___ 3921 D&RGW 16" BRAKE WHEEL-BRN DELRIN	2	1.95
___ 3922 72"X80" WINDOW	1	4.15
___ 3923 VICTORIAN WDW W/FLAT BOX PEDIMENT-2 PANE	1	3.60
___ 3924 SAME-TRIANGULAR PEDIMENT	1	3.60
___ 3925 SAME-ARCH TOP PEDIMENT	1	3.60
___ 3926 BRICK CHIMNEY	1	3.60
___ 3927 WORKING VICTORIAN DOOR WITH FLAT BOX PEDIMENT	1	5.25
___ 3928 SAME-WITH TRIANGULAR PEDIMENT	1	5.25
___ 3929 SAME-WITH ARCHTOP PEDIMENT	1	5.25
___ 3930 8 PANE DOUBLE HUNG WDW-28"X64"	2	4.40
___ 3931 12 PANE DOUBLE HUNG WDW-37"X64"	2	4.40
___ 3932 8 PANE DOUBLE HUNG WDW-28"X52"	2	4.40
___ 3933 8 PANE DBL HUNG PEAKED WDW-28"X26"	2	4.40
___ 3934 5 PANEL DOOR-1 5/8"X3 9/16"	1	4.15
___ 3935 DOOR W/SQ WDW-1 5/8"X3 9/16"	1	4.40
___ 3936 4 PANEL DOOR-1 5/8"X3 9/16"	1	4.15
___ 3937 OVAL WDW DOOR-1 5/8"X3 9/16"	1	4.40
___ 3938 5 PANEL DOOR W/2 LIGHT TRANSOM 1 5/8" X 4 1/4"	1	4.40
___ 3939 DOOR W/SQ WDW WITH 2 LIGHT TRANSOM 1 5/8" X 4 1/4"	1	4.70
___ 3940 4 PANEL DOOR W/2 LIGHT TRANSOM 1 5/8" X 4 3/16"	1	4.40
___ 3941 DOOR W/OVAL WDW W/2 LIGHT TRANSOM	1	4.70
___ 3942 GABLE TRIM	2	2.20
___ 3943 EAVE BRACKET	4	1.95
___ 3944 PORCH BRACKET	4	1.95
___ 3945 3 PANEL DOOR W/WDW	1	4.40
___ 3946 LEADED GLASS DOOR	1	4.40
___ 3947 VICTORIAN 4 PANEL DOOR	1	4.15
___ 3948 3 PANEL DOOR W/WDW-W/2 LT TRANSOM	1	4.70
___ 3949 LEADED GLASS DOOR W/2 LIGHT TRANSOM	1	4.70
___ 3950 VICTORIAN 4 PANEL DOOR W/2 LT TRNSM	1	4.40

S SCALE PARTS

4001....

___ 4001 D&RGW BOX CAR HARDWARE		3.60
___ 4002 36"X56" WINDOW-DOUBLE HUNG-12 PANE	4	1.95
___ 4003 30" 5 PANEL DOOR/FRAME	3	1.95
___ 4004 D&RGW STOCK CAR DOORS	2	1.50
___ 4005 D&RGW STOCK CAR DOORS/END DETAIL		1.65
___ 4006 COACH SEATS W/2 WOOD ENDS-STD GA.		3.00
___ 4007 SAME-W/1 WOOD END-NARROW GAUGE		2.75
___ 4008 STAKE POCKETS W/SINGLE U-BOLT	24	1.95
___ 4009 60"X120" WDW-DOUBLE HUNG-40 PANE	3	1.95
___ 4010 LIGHT WAGON WHEELS-44" AND 48"	2 EA	1.95
___ 4011 OLD TIME LOCO BELL-55 1/2"	1	1.40
___ 4012 D&RGW HI SIDE GON HARDWARE		3.60
___ 4013 GRIFFIN DENVER 26" WHEELSETS		TEMP DISC.
___ 4014 NARROW/STD GAUGE REEFER HARDWARE		1.65
___ 4015 D&RGW 30' REEFER CAR ICE HATCHES AND HARDWARE		1.65
___ 4016 STD. GA REEFER CAR ICE HATCHES WITH HARDWARE		1.65
___ 4017 30' REEFER CAR END DETAIL AND COUPLER POCKET		1.65
___ 4018 D&RGW FREIGHT CAR STIRRUP STEPS BROWN DELRIN	20	1.95
___ 4019 D&RGW TURNBUCKLES	12	1.65
___ 4020 FREIGHT CAR LADDERS-7 RUNG- BROWN DELRIN	4	1.95
___ 4021 D&RGW STAKE POCKETS-2 U-BOLTS	28	1.95
___ 4022 D&RGW ARCHBAR TRUCKS-3'7"WB BROWN DELRIN	1 PR	7.70
___ 4023 SAME-BLACK DELRIN	1 PR	7.70
___ 4024 30"X78" WDW-DBL HUNG-2 PANE	2	1.95
___ 4025 36" DOOR W/2 PANE WDW	2	1.65
___ 4026 36"X56" WDW-DBL HUNG-16 PANE	3	1.95
___ 4027 27"X38" WDW-DBL HUNG-8 PANE	3	1.95
___ 4028 36"X64"-WDW-DBL HUNG-12 PANE	3	1.95
___ 4029 27"X64" WDW-DBL HUNG-8 PANE	3	1.95
___ 4030 DIAGONAL SHEATHED SHED DOOR	4	1.95
___ 4031 3" QUEENPOSTS-D&RGW BOX,STOCK,CABSE	24	1.65
___ 4032 RGS STYLE DEPOT WDW-36"X76" 2/9 LIGHT	4	1.95
___ 4033 RGS STYLE EAVE TRIM-OPHIR	4 PCS	2.20
___ 4034 RGS STYLE GABLE TRIM-OPHIR	4 PCS	2.20
___ 4035 RGS STATION ROOF CRESTING AND FINIALS-OPHIR	SET	2.50
___ 4036 RGS STYLE DEPOT WDW-36"X82"-4 PANE	4	1.95
___ 4037 RGS STYLE DEPOT WDW-32"X53"-SINGLE WDW-58"X53"DBL WDW-9 AND 18 PANE		1.95
___ 4038 RGS STYLE DEPOT WDW-24"X82" SINGLE AND 72"X82" DBL-4 AND 8 PANE		1.95
___ 4039 RGS STYLE DEPOT DOOR W/WDW&TRANSOM	2	1.95
___ 4040 RGS STYLE FREIGHT DOOR W/TRANSOM	3	3.00
___ 4041 RGS STYLE DEPOT WDW-32"X53" SINGLE AND 58"X60" DBL-10 AND 20 PANE		1.95
___ 4042 D&RGW TURNBUCKLES IN BRASS	4	5.25
___ 4043 D&RGW 3" QUEENPOSTS IN BRASS	8	5.25

CAR COMPONENTS, MISCELLANEOUS HARDWARE, ARCHITECTURAL

4045 RGS STYLE DEPOT DBL WDW-68"X76" 11. PANE	2	1.95	5028 30" DOOR W/WDW AND FRAME	3	1.65
4046 WDW-34"X32"-2 PANE-SINGLE SASH	8	1.95	5029 27"X64" WDW-DBL HUNG-8 PANE	8	1.95
4047 WDW-28"X28"-4 PANE-SINGLE SASH	8	1.95	5030 27"X48" WDW-DBL HUNG-8 PANE	8	1.95
4048 D&RGW BOX CAR COUPLER POCKET	4	1.95	5031 36"X64" WDW-DBL HUNG-12 PANE	8	1.95
4049 D&RGW NARROW COACH WINDOW	12	1.95	5032 36"X52" WDW-DBL HUNG-16 PANE	8	1.95
4050 DBL DOOR W/IRON SHUTTERS-5'5X9'7"	2	1.95	5033 4 WHEEL BAGGAGE WAGON	1 KIT	2.15
4051 COMMERCIAL STOREFRONT SET		4.15	5034 ORNAMENTAL WOOD PORCH RAIL/BRACKET	4 PCS	1.95
4052 COMMERCIAL STOREFRONT DBL DOOR	1	1.65	5035 TURNED SPINDLE PORCH RAILING	3 PCS	1.95
4053 COMMERCIAL STOREFRONT SINGLE DOOR	2	1.65	5036 D&RGW STAKE POCKETS-2 U-BOLTS	24	1.95
4054 COMMERCIAL STOREFRONT DOUBLE WDW	2	1.65	5037 D&RGW 16" BRAKE WHEEL	4	1.95
4055 COMMERCIAL STOREFRONT SINGLE WDW	2	1.65	5038 WATER TANK HOOP FASTENERS	99	3.00
4056 39"X59" STATION WDW-4 PANE	4	1.95	5039 D&RGW SCALE TURNBUCKLES	24	1.95
4057 WESTINGHOUSE AB BRAKE SET W/ AJAX HANDBRAKE	1 SET	4.70	5040 WESTINGHOUSE TYPE K NARROW GAUGE BRAKE SET		1.40
4058 48"X96" MASONRY WDW-24 PANE	4	1.95	5041 55 GALLON DRUMS, FIRE BARREL LIDS	12	1.95
4059 C&S 6 SPOKE BRAKE WHEEL	4	1.95	5042 36" RESIDENCE DOOR W/OVAL WDW & FR	2	1.65
4060 SMOKE JACK	2	1.65	5043 PASSENGER CAR ROOF DETAIL	4	1.95
4061 ROTARY TYPE STATION ORDER BOARD	1	1.95	5044 D&RGW 30' REEFER CAR COUPLER PKT	4	1.95
4062 AJAX BRAKE WHEEL-DELRIN	3	2.20	5045 1" SQ NUTS, BOLTS, WASHERS	175	1.95
4063 ROUND MASONRY WDW-48" DIA. -9 PANE	2	1.65	5046 1 3/4" SQ NUT, BOLT, WASHER	175	1.95
4064 C&S NARROW GAUGE NY BRAKE SET		2.20	5047 D&RGW DROP BOTTOM GON COUPLER PKT	4	1.95
4065 C&S-RGS/WP&Y 54" BETTENDORF TRUCKS-BROWN DELRIN	1 PR	7.70	5048 COACH SEATS -NARROW GAUGE-WOOD ENDS	12	2.75
4066 WDW/DOOR/TRIM GRAB BOX		17.55	5049 COACH SEATS-STD GAUGE-2 WOOD ENDS	12	3.00
4067 RESIDENCE DOOR W/WDW	2	1.95	5050 6" QUEENPOSTS	24	1.95
HO SCALE PARTS			5051 5" QUEENPOSTS	24	1.95
5001....			5052 3" QUEENPOSTS	24	1.95
5001 D&RGW BOX CAR HARDWARE		3.60	5053 10" QUEENPOSTS	24	1.95
5002 D&RGW HI SIDE GON HARDWARE		3.25	5054 WATER TANK SPOUT SET	1	1.85
5003 PLASTIC DUMMY COUPLERS	10	1.95	5055 GRIFFIN DENVER 26" WHEELSETS- PLASTIC FOR SCENERY ONLY-2 STYLES	8 PAIR	3.00
5004 D&RGW STOCK CAR HARDWARE		3.25	5056 D&RGW BOX CAR END ROOF WALKS	4	1.95
5005 D&RGW REEFER CAR HARDWARE		3.25	5057 D&RGW STATION CHIMNEY	3	1.95
5006 D&RGW BOX CAR COUPLER POCKETS	4	1.95	5058 D&RGW STATION DOOR W/FR&TRANSOM	3	1.95
5007 D&RGW CABOOSE STOVE AND STACK	1	1.65	5059 OUTFIT CAR WINDOWS	8	1.95
5008 D&RGW PASSENGER CAR STOVE AND STACK	1	1.65	5060 30"X69" STATION WDW-4 PANE	8	1.95
5009 36"X56" DBL HUNG WDW-12 PANE	8	1.95	5061 HEAVY CAST IRON SWITCH STAND	1	1.65
5010 60"X120" ROUNDHOUSE WDW-40 PANE	6	1.95	5062 LAMP REFLECTORS	18	1.95
5011 SILVERTON STATION ROUND ATTIC WDW	4	1.95	5063 D&RGW CABOOSE DOORS	4	1.95
5012 STAKE POCKETS-SINGLE U-BOLT	24	1.95	5064 BAND STAND LATTICE	8 PCS	2.50
5013 DURANGO STATION DOOR W/FR & TRANSOM	2	1.65	5065 MASONIC HALL BALCONY RAILING AND BRACKET SET	2 PCS	2.00
5014 DURANGO STATION WDW-36"X87"-4 PANE	8	2.50	5066 1 1/4" NUT, 3" MALLEABLE IRON WASHER	175	1.95
5015 DURANGO STATION WAINSCOT	5 PCS	2.20	5067 LOVSTED 15" BRAKE WHEEL-WESTSIDE LUMBER COMPANY	4	1.95
5016 DURANGO STATION WDW-36"X44"-2 PANE	8	1.95	5068 ULTX TANK CAR ENDS	2	1.65
5017 WELLS FARGO BALCONY RAILING	3 PCS	1.95	5069 D&RGW NARROW GAUGE COACH WINDOWS	30	2.50
5018 UPPER PORCH SPOOL TRIM	4 PCS	1.95	5070 D&RGW COACH END DOORS	4	1.95
5019 GAY NINETIES PORCH RAIL	4 SET	1.95	5071 D&RGW COMBINE BAGGAGE DOORS	4	1.95
5020 WELLS FARGO BRICK CORNICE	4 PCS	1.95	5072 DOOR-4 LIGHT W/TRANSOM	4	1.95
5021 30" 5 PANEL DOOR W/FRAME	3	1.65	5073 DOUBLE DOOR W/TRANSOM	2	1.65
5022 ASSAY OFFICE DBL DOOR-5'9"-12 PANE	2	1.65	5074 CORBELS-DOUBLE S-3"8"	12	1.95
5023 STOVEPIPE W/ELBOW, BONNET, THIMBLE	2	1.65	5075 CORBELS-DOUBLE S-26"	24	1.95
5024 FAIRMONT 36" PUSH CAR KIT	1	1.95	5076 CORNICE TRIM-APPROX. 6'6"X20"	120	3.00
5025 RGS STATION EAVE TRIM	6	1.95	5077 WDW-SINGLE SASH-72"X102"-12 PANE	4	1.95
5026 RGS STATION GABLE TRIM	4	1.95	5078 D&RGW COACH ARCH TOP END DOORS	4	1.95
5027 RGS STATION ROOF TRIM	7 PCS	2.50	5079 TURNED WOOD PORCH COLUMNS	8	1.95

5080	D&RGW STATION BAGGAGE DOORS	3	1.95	5128	D&RGW HI SIDE GON NEEDLEBEAM AND QUEENPOST SUB-ASSEMBLY	4	1.95
5081	52"X33" HORIZONTAL SLIDING WDW	8	1.95	5129	STIRRUP STEPS FOR BOX,FLAT,STOCK, AND HI SIDE GONS-BROWN DELRIN	24	1.95
5082	CRANK PIN DETAIL		1.65	5130	SAME-BLACK DELRIN	24	1.95
5083	PORCH/LANAI RAILING	6 PCS	2.50	5131	DOOR W/FRAME-2 TONGUE & GROOVE PNL	3	1.65
5084	ENGINE HOUSE STACK SET-(2)18", (1)9"		2.50	5132	26" NON-MAGNETIC WHEELSETS-36" GA.	4 AXLE	3.30
5085	LIFT RING AND EYEBOLT ASSORTMENT	108	1.95	5133	ROUNDHOUSE DOORS-14'6"X19" WITH WINDOWS AND HINGES	1 SET	2.50
5086	D&RGW HI SIDE GON COUPLER POCKET AND END DETAIL	2 SETS	1.65	5134	36" DOOR WITH WDW/TRANSOM	3	1.65
5087	GOTHIC CHURCH AND RESIDENCE WINDOW 4'X9'6"	4	1.95	5135	2 1/2" HEX NUT,BOLT	100	1.95
5088	STATION DOOR-4 PANEL 30"	3	1.95	5136	DBL DOOR W/IRON SHUTTERS-5'X9'7"	2	1.95
5089	STATION ORDER BOARD-ROTARY TYPE	1	1.95	5137	SGL DOOR W/IRON SHUTTERS-4'2X9'7	2	1.95
5090	D&RGW/RGS SHORT CABOOSE END DETAIL BOLSTER,NEEDLEBEAM		1.95	5138	STORE WINDOW-5'5X9'7	4	1.95
5091	60" DIAMETER HEAD-FRAME SHEAVE	2	1.65	5139	FACTORY FRONT DOOR 39X92 WITH TRANSOM FOR MASONRY BUILDINGS	2	1.65
5092	ROUNDTOP WDW-5X12'6"-53 PANE	4	1.95	5140	FACTORY WINDOW 42"X91" DOUBLE HUNG 4 PANE FOR MASONRY BUILDINGS	4	1.95
5093	2 1/2" NUTS,5" MALLEABLE WASHERS	100	1.95	5141	HON3 20" WHEELSETS-DELRIN-W/2 3/4" BRASS AXLES	4	2.20
5094	2 1/2" NUTS,CARTER BROS. ELIPTICAL WASHERS	100	1.95	5142	SAME-HON30"	4	2.20
5095	HINGE ASSORTMENT	2 SETS	1.65	5143	CIRCUS WAGON WHEELS-36" AND 48" DIA	2 SETS	2.15
5096	2 1/2" NUT,6" SQUARE WASHERS	100	1.95	5144	ANDREWS TRUCK-56"WB D&RGW-5900 STOCK,150 REEFER,6400 FLAT BROWN DELRIN	1 PAIR	4.95
5097	ENGINE HOUSE WDW-42"X91"-18 PANE		1.95	5145	SAME-BLACK DELRIN	1 PAIR	4.95
5098	2 1/2" NUT,4 1/2" FLAT STEEL WASHR	175	1.95	5146	SR&RL HON30 ARCHBAR TRUCK-4'8"WB BLACK DELRIN WHEELS AND BRASS AXLES	1 PAIR	4.95
5099	3" NUTS,4 1/2" FLAT STEEL WASHER	100	1.95	5147	KOPPEL 4 WHEEL 3 1/2 YARD GABLE BOTTOM DUMP CAR-HON30 SILVER WHEELS IN BRASS AXLES	2 KITS	7.15
5100	1 3/4" NUTS,2 1/2" STEEL WASHERS	175	1.95	5148	SAME-HON3	2 KITS	7.15
5101	1 7/8" NUT,3/16" STEEL WASHER	175	1.95	5149	DBL DOOR W/SIDELIGHT AND TRANSOM 89 1/2" X 130"	2	1.65
5102	ENGINE HOUSE DOORS AND HINGES 6'6" X 14'6"	4	2.50	5150	PEAKED CAP WDW-1/2 ROUND UPPER SASH 41" X 90"	8	1.95
5103	RUSSEL LOG CAR HARDWARE	1 SET	1.65	5151	BRACKETS-14"X17 1/2"	20	1.65
5104	PACIFIC CAR AND FOUNDRY LOG BUNKS	2	1.65	5152	6' UPPER PORCH TRIM DRAPERY	8	1.65
5105	WESTSIDE LUMBER CO. FLAT CAR HDW		1.65	5154	31"X65" DBL HUNG MASONRY WINDOW W/STONE LINTEL AND SILL	8	1.95
5106	STD GAUGE REEFER CAR HARDWARE		3.00	5155	DUMMY RAIL CLIPS WITH BOLTS FOR TIGHT CURVES,BRIDGES,CONCRETE TIES		1.95
5107	ATTIC VENTS-LOUVRED VICTORIAN STYLE	4	1.95	5156	2 1/2" NUT W/6 1/2" CAST IRON WASHER-CORED FOR .020" WIRE	80	1.95
5108	GONDOLA STAKES FOR 12" WIDE BOARD WITH POCKETS	40	2.50	5157	WAREHOUSE AND FACTORY OFFICE DOOR AND WINDOW SET-115"X97"	2 SETS	1.95
5109	DBL DOOR W/FRAME & TRANSOM-ROUND AND RECTANGULAR PANES	3	1.95	5158	WAREHOUSE DOORS-"ROLL-UP"12'6X14'3 AND 36" STEEL PERSONNEL DR-42"X84"	2 SETS	1.95
5110	D&RGW FREIGHT TRUCKS-NON-MAGNETIC WHEELS-BROWN DELRIN	1 PAIR	4.95	5159	D&RGW ARCHBAR TRUCKS-4'8"WB BROWN DELRIN	1 PAIR	4.95
5111	SAME-BLACK DELRIN	1 PAIR	4.95	5160	QUEEN ANNE DBL HUNG PAIRED WDW-5'6"X6'6"-4 PANE	3	1.95
5112	ATTIC WDW-RECTANGULAR-6 PANE	8	1.95	5161	QUEEN ANNE DBL HUNG SINGLE WDW-2'8"X6'6"-4/4 PANE	3	1.95
5113	2 1/2" NUT ON RECTANGULAR WASHER	100	1.95	5162	QUEEN ANNE TRIM SET		1.95
5114	GE 23 TON BOX CAB DIESEL ELECTRIC LOCO-DUMMY ONLY-NARROW GAUGE	1 KIT	19.25	5163	33" DOOR W/6 PANE WDW AND TRANSOM	3	1.95
5115	VICTORIAN STOREFRONT DOOR & WDW SET	1	1.65	5164	STD. GAUGE FAIRMONT PUSHCAR	1 KIT	1.65
5116	VICTORIAN WDWs-4 SINGLE AND 2 DBL	2 SETS	1.95	5165	COMMERCIAL STOREFRONT WDW AND DOOR	2 SETS	2.50
5117	36"X64" DBL HUNG WDW-4 PANE	8	1.95	5166	NG REEFER CAR DOOR LATCH BAR	4	1.95
5118	HINGE SET FOR SIDE DUMP GONDOLAS	2 SETS	1.65	5167	SG REEFER CAR DOOR LATCH BAR	4	1.95
5119	VICTORIAN PICKET FENCE & GATE POSTS	1 SET	1.95				
5120	C&S RGS/WP&Y BETTENDORF TRUCK-54"-NON-MAGNETIC WHEELS-BROWN DELRIN	1 PAIR	4.95				
5122	CABLE SHEAVE-43" DIA W/BEARINGS	2	1.65				
5123	2 1/2" NUT,6 1/2" CAST IRON WASHER	100	1.95				
5124	FREIGHT CAR LADDERS	20	1.65				
5125	BOLSTER-CAST STEEL MODIFIED STD GAUGE FOR HI SIDE GON	4	1.65				
5126	GOTHIC CHURCH & RESIDENCE WDW-5X15	4	1.95				
5127	GE 23TON BOX CAB DIESEL ELECTRIC LOCO-DUMMY ONLY-STANDARD GAUGE	1 KIT	19.25				

5168 REEFER CAR HINGES	48	1.95	5213 SEE 5900		
5169 D&RGW BOX/STOCK CORNER IRONS	4	SETA 1.95	5214 C&S STEEL UNDERFRAME GONDOLA KIT		19.95
5170 D&RGW STOCK CAR DOORS	2	1.65	5215 4 PANE DOUBLE HUNG WDW-30"X62"	8	1.95
5171 VICTORIAN CORBELS	28	1.95	5216 SCALLOPED SHINGLES	2	SHTS 1.95
5172 EAVE BRACKET AND LOUVRED VENT	4	SETS 1.95	5217 WOODEN BARRELS	12	2.15
5173 LOUVRED WDW SHUTTERS-18"X56"	16	1.95	5218 CORRUGATED ROOF MATERIAL	2	SHTS 1.95
5174 SAME-18X68	16	1.95	5219 BUILDING DATE PLAQUES W/NUMBERS	2	SETS 1.95
5175 SAME-18X87	16	1.95	5220 POINTED TOP DOUBLE HUNG WDW	8	1.95
5176 35 DEGREE CONCRETE AND STEEL STAIRCASE WITH OPEN RISERS		1.95	5221 8 PANE DOUBLE WDW-63X69	4	1.95
5177 39 DEGREE WOODEN STAIRCASE W/OPEN RISERS AND LANDING		2.15	5222 16 PANE DOUBLE WDW-59X64	4	1.95
5178 BRACKET FOR PORCH TRIM	24	1.65	5223 GABLE AND DORMER WDW	4	1.95
5179 42X72 MASONRY DOUBLE HUNG WDW	6	1.95	5224 8X8 NY AIR BRAKE SET-TYPE K	1	1.40
5180 6" QUEENPOST AND BEAM	4	1.95	5225 C&S 6 SPOKE BRAKE WHEEL	4	1.95
5181 3" QUEENPOST AND BEAM	4	1.95	5226 C&S BOX CAR KIT		19.95
5183 D&RGW BOLSTER AND END BEAM	2	1.65	5227 GABLE TRIM	4	1.65
5184 BRAKE ROD WITH CLEVIS	6	1.95	5228 NEWEL POST	8	1.65
5185 NARROW GAUGE FREIGHT CAR UNCOUPLING LEVERS-DELTRIN		1.95	5229 SPOOL TRIM BRACKET	8	1.65
5186 RIO GRANDE 30' FLAT CAR KIT		16.45	5230 2X6 SINGLE ROUNDTOP WDW-DBL HUNG	8	1.95
5187 WHEEL AND TIE CAR KIT		20.95	5231 C&S/RGS 30' REFRIGERATOR CAR KIT		19.95
5188 D&RGW DROP BOTTOM GONDOLA KIT		29.65	5232 WESTINGHOUSE AB BRAKE SET-STD GA.		3.00
5189 BRAKE ROD WITH CHAIN	2	1.65	5233 DBL HUNG WDW-32X70-6/4 PANE	8	1.95
5190 D&RGW DROP BOTTOM GONDOLA STIRRUP STEPS-BROWN DELTRIN	20	1.95	5234 POINTED TOP WDW-30X86	8	1.95
5191 GRAB IRON BENDING FIXTURE		1.40	5235 C&S CABOOSE KIT		19.95
5192 WINDOW GRAB BOX-OVER \$20.00 VALUE		16.45	5236 C&S CABOOSE PEDESTALS AND JOURNAL BOX LIDS	4	2.20
5193 RGS STYLE DEPOT WDW-36"X76" 2/9 PANE	8	1.95	5237 C&S CABOOSE STEPS		1.40
5194 RGS STYLE DEPOT WDW-32X53 SINGLE AND 58X53 DOUBLE-9 AND 18 PANE		1.95	5238 C&S CABOOSE LADDERS	2	2.20
5195 RGS STYLE DEPOT WDW-36X82 4 PANE	4	1.95	5239 SINGLE SASH-4 PANE WDW-28X26	4	1.95
5196 RGS STYLE DEPOT WDW-24X82 SINGLE AND 72X82 8 PANE DOUBLE		1.95	5240 ROUND MASONRY WDW-65" DIAMETER	2	1.65
5197 RGS STYLE DEPOT DOOR-W/WINDOW AND TRANSOM-36X84	4	1.95	5241 SHED OR ATTIC WINDOW-4 PANE	8	1.95
5198 RGS STYLE DEPOT FREIGHT DOOR WITH TRANSOM	3	2.50	5242 HORIZONTAL WDW-6 PANE	8	1.95
5199 RGS STYLE DEPOT WDW-10 PANE-24X44 SINGLE AND 20 PANE 51.5X51 DOUBLE		1.95	5243 DOOR GRAB BOX		14.30
5200 RGS STATION EAVE TRIM-OPHIR	4	1.65	5244 TRIM GRAB BOX		16.45
5201 RGS STATION GABLE TRIM-OPHIR	4	1.65	5245 WINDOW AND TRANSOM SET		1.95
5202 RGS STATION ROOF CRESTING & FINIAL		2.75	5246 WIDOW'S WALK RAILING	4	PCS 2.50
5203 RGS STYLE WDW-36X82 DBL 22 PANE	4	1.95	5247 PEAKED DOUBLE HUNG 11 PANE CHURCH OR RESIDENCE WDW-7/16X1 1/4-BODIE	8	1.95
5204 DBL HUNG TRIPLE WDW-100X92-6 PANE	3	1.95	5248 PEAKED ATTIC WDW-SNGL PANE-3/8X9/16	8	1.95
5205 DBL HUNG DBL WDW-65X92-	3	1.95	5249 VICTORIAN DOUBLE PANE WINDOW	8	1.95
5206 DIAMOND PATTERNED WINDOW	2	1.65	5250 4 PANE DBL HUNG WINDOW	8	1.95
5207 STD GA. BOX CAR DOOR W/CAMEL HDW	2	1.95	5251 HORIZONTAL WINDOW	8	1.95
5208 PAIRED WDW-DBL HUNG-35X48-32 PANE FROM YOSEMITE VALLEY RR-BAGBY STA.	4	1.95	5252 DOUBLE WINDOW	8	1.95
5209 SGL WDW-DBL HUNG-34X67 -16 PANE- FROM YOSEMITE VALLEY RR-BAGBY STA.	6	1.95	5253 HON3 C&S/RGS STEEL UNDERFRAME STOCK CAR		19.95
5210 48 PANE WDW-DBL HUNG-186X70 -BAGBY	2	1.95	5254 GOTHIC WINDOW	8	1.95
5211 ARCHITECTURAL DETAILS-DENTILS	3	1.65	5255 8 PANE DOUBLE HUNG WINDOW	8	1.95
5212 PAIRED ROUND TOP DOUBLE HUNG WDW- 4'6"X6'3"	4	1.95	5256 20 PANE ARCHED WINDOW	8	1.95
			5257 #5146 WITH NWSL WHEELS		PR 6.50
			5258 GABLE TRIM ASSORTMENT	2	1.95
			5259 POINTED TOP FRONT WDW/DOOR SET	2	1.95
			HO SCALE BUILDING KITS		
			5900...		
			5900 "SECOND CLASS" SALOON BUILDING KIT		16.45
			5901 EAST TERRIBLE MILL MINING CO. KIT		27.50
			5902 WENTAMUCK MINE KIT		24.95
			5903 REESE STREET ROW HOUSES KIT	3	24.95

**HO SCALE BRASS
86001....**

86003 DUMMY COUPLERS	2	5.25
86012 STAKE POCKETS-SINGLE U-BOLT	12	9.90
86024 NG PUSHCAR KIT	1	11.55
86033 4 WHEEL BAGGAGE WAGON KIT		18.70
86036 D&RGW STAKE POCKET-2 U-BOLT	12	9.90
86037 D&RGW 16" BRAKE WHEEL-5 SPOKE	2	10.45
86039 D&RGW TURNBUCKLES	16	9.90
86040 WESTINGHOUSE TYPE K BRAKE SET		8.75
86043 PASSENGER CAR ROOF DETAIL	1 SET	5.35
86045 1" SQUARE NBW	35	5.35
86046 1 3/4" SQUARE NBW	35	5.35
86050 6" QUEENPOSTS	6	5.35
86051 5" QUEENPOSTS	6	5.35
86052 3" QUEENPOSTS	6	5.35
86053 10" QUEENPOSTS	6	5.35
86066 1 1/4" NUT,3" MALLEABLE WASHER	20	5.35
86067 LOVSTED 15" BRAKE WHEEL	2	10.45
86082 CRANK PIN DETAIL		5.35
86085 EYEBOLT AND LIFTRING ASST		5.35
86090 D&RGW/RGS SHORT CABOOSE END DETAIL, BOLSTERS,NEEDLEBEAMS		9.90
86091 60" DIA. HEAD-FRAME SHEAVE W/BRGS	1	5.35
86093 2 1/2" NUTS,MALLEABLE WASHERS	20	5.35
86094 2 1/2" NUTS,CARTER BROS. ELIPTICAL WASHERS	20	5.35
86095 HINGE ASSORTMENT		5.35
86096 2 1/2" NUTS,6" SQUARE WASHERS	20	5.35
86098 2 1/4" NUTS,4 1/2" FLAT STEEL WSHR	35	5.35
86099 3" NUTS,4 1/2" FLAT STEEL WASHERS	35	5.35
86100 1 3/4" NUTS,2 1/2" STEEL WASHERS	35	5.35
86101 BLW 36" DRIVER CENTER-D&RGW C-16	8	26.40
86102 BLW 46" DRIVER CENTER-D&RGW T-12	6	23.95
86103 PILLOW BLOCKS FOR DBG DOOR RELEASE BAR AND MANY OTHER USES	12	5.35
86104 16" PRESSED STEEL WHEELS/PILOT WHEELS ON GALLOPING GOOSE & OTHERS	4	10.45
86105 7/8" NUTS,3 3/16" STEEL WASHERS	35	5.35
86113 2 1/2" NUTS ON RECTANGULAR WASHERS	20	5.35
86123 2 1/2" NUTS,6 1/2" CAST IRON WSHRS	20	5.35
86129 FREIGHT CAR STIRRUP STEPS	4	5.75
86135 2 1/2" HEX NUT,BOLT	20	5.35
86156 2 1/2" NUTS W/6 1/2" CAST IRON WASHER CORED FOR .020" WIRE	20	5.35
86180 6" QUEENPOST AND BEAM		5.35
86181 3" QUEENPOST AND BEAM		5.35
86183 D&RGW BOLSTER AND ENDBEAM		5.35

**N SCALE PARTS
8001....**

8001 36"X56" WDW/36" DOORS	2 SETS	1.95
8002 8'X16' WINDOW-40 PANE	8	1.95
8003 CABLE SHEAVE-38"DIAMETER	3	1.95
8004 60"X96" DBL HUNG-12 PANE	8	1.95
8005 27"X48" DBL HUNG WDW-8 PANE	16	1.95
8006 36" DOOR ASSORTMENT	2 SET	1.95
8007 27"X64" DBL HUNG WDW-8 PANE	12	1.95
8008 36"X64" DBL HUNG-12 PANE WDW	12	1.95
8009 52"X33" DBL HUNG WDW-8 PANE	12	1.95
8010 36"X56" DBL HUNG WDW-12 PANE	12	1.95
8011 BAGGAGE DOOR ASSORTMENT	2 SET	1.95
8012 ENGINE HOUSE WDW TO FIT 64"X127" 40 PANE	8	1.95
8013 FACTORY WDW-44"X92" DBL HUNG- 4 PANE FOR MASONRY BUILDINGS	8	1.95
8014 WAREHOUSE AND FACTORY OFFICE DOOR AND WINDOW SET 115"X97"	2 SET	1.95
8015 WAREHOUSE DOORS-"ROLL UP"-12'6X14'3 36" STEEL PERSONNEL DOOR-42"X84"	2 SET	1.95
8016 EAVE BRACKET AND LOUVRED VENT	4 SET	1.95
8017 VICTORIAN DEPOT DOOR W/TRANSOM-32"	8	1.95
8018 VICTORIAN BAGGAGE DOOR-80"	4	1.95
8019 STATION WDW-30"X69"-4 PANE	12	1.95
8020 VICTORIAN WDW-SINGLE & DOUBLE	2 SET	1.95
8021 WDW/DOOR/MISC. GRAB BOX		16.45
8022 VICTORIAN PICTURE WINDOW	8	1.95

**TRACK COMPONENTS
9001....**

MADE IN 1/4" SCALE, BUT MAY BE USABLE IN OTHER SCALES

9001 CODE 125 TIE PLATES	100	2.20
9002 CODE 100 TIE PLATES	100	2.20
9003 CODE 70 DUMMY FISH PLATES	80	2.20
9004 CODE 100 DUMMY FISH PLATES	30	2.20
9006 CODE 100 STUB SWITCH BRIDLE-24X36	4	1.95
9007 SPIKE HEADS FOR COSMETIC PURPOSES	175	1.95

**R/ROBB LTD BOOKS
NARROW GAUGE PICTORIALS**

1 RGS/D&RGW MOTIVE POWER	25.00
2 PASSENGER CARS OF THE D&RGW	23.50
3 GONDOLAS,BOX CARS,FLAT CARS D&RGW	23.50
4 REFRIGERATOR,STOCK,TANK CARS-D&RGW	25.00
5 CABOOSES OF THE D&RGW	24.00
6 C&S MOTIVE POWER	TOS
7 D&RGW MAINTENANCE OF WAY-OA-OZ	28.50
8 C&S EQUIPMENT -ROLLING STOCK	29.00
9 RGS RIGHT OF WAY AND STRUCTURES- RICO TO DURANGO	22.00
10 D&RGW NUMBERED WORK EQUIPMENT	27.50
MUDHENS-BY DENNIS O'BERRY	28.00

PAGE 12 TRANSMISSION PARTS AND KITS

7004	UNIVERSAL JOINT BORES 3MM AND 3/32"	2	1.95	7071	*PILOT TRUCK FOR GALLOPING GOOSE WITH ROUND HOLES	1	6.60
7005	ELECTRICAL PICKUP(LOCO DRIVERS)	1	4.95	7072	*PILOT TRUCK FOR GALLOPING GOOSE	1	6.60
7006	DELTRIN CHAIN AND 8 TOOTH SPROCKETS	1 SET	7.70	7077	1:1 SKEW BEVEL GEARS-.078" BORE .125" OFFSET	2	4.15
7007	BEVEL GEARS 1/8 OD 1/32"BORE 10 TOOTH	2	1.65	7078	2:1 SKEW BEVEL GEARS-.062" AND .125" BORE-100" OFFSET-DELTRIN	2	4.15
7008	SHAFT COUPLING-FLEXIBLE DELTRIN 3/32" AND .078" BORE		2.75	7079	CLIMAX CROSS BOXES-DELTRIN	4	4.15
7009	DELTRIN U-JOINT BORE .093"	2	1.95	7080	*40" DRIVER RIMS FOR K-27	8	7.50
7010	DELTRIN U-JOINT .078"(2MM)	2	1.95	7083	BRASS BEVEL PINION-12 TOOTH 48DP	1	4.95
7011	U-JOINT .600 TO 1.00 OVERALL LENGTH TO FIT .079" (2MM) SHAFTS	2 SETS	2.20	7085	2:1 RATIO GEARS,CROSS BOX,.078" COUPLING FOR 3MM GEARS	1 SET	4.40
7012	2:1 RATIO GEAR .062" AND 3/32" BORE WITH CROSS BOX		4.35	7086	SAME-FOR 1/8" AXLES	1 SET	4.40
7013	4:1 RIGHT ANGLE GEAR TOWER-11/16" CENTER TO CENTER-.078" U-JOINT TO 3/32" AXLE		6.85	7087	DELTRIN SCREW ASSORTMENT,2-56 2MM 0-80	2 SETS	1.95
7030	2:1 RATIO GEARS-CROSS BOX .078" COUPLING LESS WHEELS		5.25	7088	**NARROW GAUGE GE 23 TON BOX CAB DIESEL ELECTRIC LOCO KIT WITH MABUCHI POWER UNIT-	1 KIT	38.50
7031	SAME-WITH TWO 24" SPOKED WHEELS		7.45	7089	**SAME-STANDARD GAUGE	1 KIT	38.50
7033	CROSS BOX FOR #7077 GEARS		1.40	7090	**NARROW GAUGE GE 25 TON,150 HP INDUSTRIAL LOCOMOTIVE (CIRCA 1956) KIT WITH MABUCHI POWER UNIT	1 KIT	38.50
7034	1:1 BEVEL GEARS-IN LINE 15T-3MM BORE -48 DP-DELTRIN	2	4.15	7091	**SAME-STANDARD GAUGE	1 KIT	38.50
7035	SAME WITH 3/32" BORE	2	4.15	7092	**NARROW GAUGE WHEELSETS FROM 7088-89-90-91	2 AXLE	11.55
7036	2:1 RATIO GEARS,CROSS BOX,.078" BORE U-JOINT		5.25	7093	**SAME-STANDARD GAUGE	2 AXLE	11.55
7037	1:1 GEARS IN LINE MOUNTING BRACKET .089" COUPLING-WILL CLEAR WHEELS AS SMALL AS .032 DIA. -24" GAUGE		6.00	7094	MABUCHI MOTOR/GEAR SET-80:1/160:1 REDUCTION	SET	24.75
7039	CLIMAX U-JOINT SET		4.15	70001	DELTRIN LADDER CHAIN 6" LENGTH FOR USE WITH BELOW SPROCKETS	1	5.50
7040	1:1 SKEW BEVEL GEARS-1/8" OFFSET W/CROSS BOX-.078" BORE		5.25	70082	DELTRIN SPROCKET-1/8" SHAFT-8 TOOTH	1	1.40
7041	*SHAY GEAR SET FOR 26"&29" DRIVERS		5.75	70092	SAME-9 TOOTH	1	1.40
7043	*DRIVER RIMS-29" LIMA SHAY	8 SET	7.50	70102	SAME-10 TOOTH	1	1.40
WE WILL SUPPLY OUR WHEEL RIMS AS USED IN OUR WHEEL SETS--THEY NEED TO BE BORED OUT TO SUIT				70122	SAME-12 TOOTH	1	1.65
7044	*33"	8	5.10	70152	SAME-15 TOOTH	1	1.65
7046	*26"	8	3.85	70153	DELTRIN SPRKT-3/16" SHAFT-15 TOOTH	1	3.00
7047	*24"	8	3.85	70162	DELTRIN SPROCKET-1/8"SHAFT-16 TOOTH	1	1.65
7048	*20"	8	3.85	70182	SAME-18" TOOTH	1	1.95
7049	*40 1/2"	8	7.50	70202	SAME-20 TOOTH	1	1.95
7050	*MICRO-MO MOTOR AND GEARING FOR USH 13 TON SHAY-INCLUDES COAL LOAD TO COVER MOUNT	1 SET	82.50	* 1/4" SCALE ONLY ** HO SCALE ONLY			
7051	*MICRO-MO MOTOR AND GEARING FOR KEMTRON SHAY	1 SET	77.00				
97052	MABUCHI MOTORED STORAGE BATTERY MINE LOCOMOTIVE-30" KIT		41.25				
97053	SAME-36" KIT		41.25				
97058	*NEVADA COUNTY NG #10 PLYMOUTH INDUSTRIAL LOCO-36" GAUGE-POWERED		55.00				
97059	5 TON PLYMOUTH FL1 SWITCHER-ON3-POWERED		49.50				
97060	*SAME-36" GAUGE		49.50				
97061	SAME-24" GAUGE		49.50				
7062	*MICRO-MO MOTOR AND GEAR FOR 3060-3062-3063 PORTERS-36" GAUGE		82.50				
7063	*MICRO-MO MOTOR UNIT AND GEAR TOWER FOR 3065-66 PORTER LOCOS		94.50				

PRICE LIST ADDITIONS-SEPTEMBER

1996

IN 1/4" SCALE (O SCALE)

3561	ARCHED GABLE TRIM	2/1.95
3562	GRID GABLE TRIM	2/1.95
3563	FAN GABLE TRIM	2/1.95
3564	SUNBURST GABLE TRIM	2/1.95
3565	COMMERCIAL STOREFRONT SET	5.50

IN 1/2" SCALE (G SCALE)

3951	ARCHED GABLE TRIM	2/2.20
3952	GRID GABLE TRIM	2/2.20
3953	FAN GABLE TRIM	2/2.20
3954	SUNBURST GABLE TRIM	2/2.20

NEW!! IN 1/4" SCALE
"GRAND LITTLE PROJECTS"
FOR WORKSHOP FUN

3401	FIREHOUSE-A FUN PROJECT THAT TURNS A MATCHBOX INTO A FIREHOUSE. KIT INCLUDES: BRICK WALLPAPER- WINDOWS-DOORS-ACETATE-LAMPS- SIGN-BELL-BRACKET-ROOF. Kit does not include matchbox	10.95
3402	"AUNT MARTHA'S WINDOW DOME PROJECT- INCLUDES GLASS DOME-WOOD BASE- WALL-FLOOR-WINDOW-ACETATE- WINDOW BOX- PLANTS-WALLPAPERS	18.95

GRANDT LINE PRODUCTS

1040 B SHARY CT CONCORD, CA 94518
(510) 671-0143 FAX 671-0806

DATE

ORDER FORM

P.O. NO.

SOLD TO:

SHIP TO:

PROVIDE UPS ADDRESS IF POSSIBLE

QTY	DESCRIPTION	PRICE	QTY	DESCRIPTION	PRICE

CREDIT CARD ORDERS:

MASTERCARD EXPIRATION DATE:
 VISA
 MONTH YEAR

_____ AUTHORIZED SIGNATURE

ORDER TOTAL	ADD
\$0.00-20.00	4.10
20.01-50.00	5.10
50.01-75.00	6.10
75.01 AND UP	7.10

ADDITIONAL SHIPPING CHARGES:

UPS 2-DAY AIR: ADD EXTRA 3.75
COD ORDERS: ADD EXTRA 4.75
NOTE: OTHER UPS SERVICES AVAILABLE ON REQUEST
OVERSEAS CUSTOMERS ADD EXTRA 12.50

SUB TOTAL	
CA SALES TAX	
SHIPPING	
TOTAL DUE	

SHIP VIA: UPS GROUND UPS 2-DAY US MAIL

PAYMENT BY: CHECK COD

ALLOW 2-8 WEEKS FOR DELIVERY

